



# Power Edger

## *Operator's Manual*

**MODELS**

**PE-230**

**Serial Number 03001001 - 04999999**

**PE-260**

**Serial Number 03001001 - 04999999**

**WARNING**  **DANGER**



The muffler or catalytic muffler and surrounding cover may become extremely hot.

Always keep clear of exhaust and muffler area, otherwise serious personal injury may occur.

 **WARNING** 

The engine exhaust from this product contains chemicals known to the State of California to cause cancer, birth defects or other reproductive harm.

**WARNING**  **DANGER**



Read rules for safe operation and instructions carefully. ECHO provides an Operator's Manual and a Safety Manual. Both must be read and understood for proper and safe operation.

## INTRODUCTION

Welcome to the ECHO family. This ECHO product was designed and manufactured to provide long life and on-the-job dependability. Read and understand this manual and the SAFETY MANUAL you found in the same package. You will find both easy to use and full of helpful operations tips and SAFETY messages.

### WARNING DANGER

Read rules for safe operation and instructions carefully. ECHO provides an Operator's Manual and a Safety Manual. Both must be read and understood for proper and safe operation.

### THE OPERATOR'S MANUAL

contains specifications and information for operation, starting, stopping, maintenance, storage and assembly specific to this product.

### THE SAFETY MANUAL —

explains possible hazards involved with the use of Edgers and the measures you should take to make their use safer.

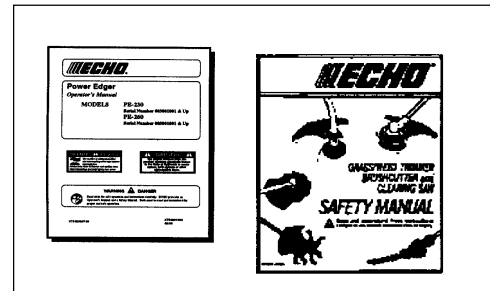

## TABLE OF CONTENTS

Introduction .....	2	- Starting Warm Engine .....	21
- The Operator's Manual .....	2	- Stopping Engine .....	22
- The Safety Manual .....	2	- Operating Techniques .....	22
Manual Safety Symbols and Important Information .	3	Maintenance .....	24
Safety .....	3	- Skill Levels .....	24
- Decals .....	3	- Maintenance Intervals .....	24
- International Symbols .....	4	- Air filter .....	25
- Equipment .....	4	- Fuel Filter .....	25
- Fuel .....	5	- Spark Plug .....	26
- Personal Condition and Safety Equipment .....	6	- Cooling System .....	26
- Safe Operation .....	7	- Exhaust System .....	27
- Extended Operation/Extreme Conditions .....	9	- Carburetor Adjustment .....	28
Description .....	10	- Blade Replacement / Lubrication .....	29
- Contents .....	10	Troubleshooting .....	31
- Emission Control .....	10	Storage .....	32
Specifications .....	14	Servicing Information .....	36
Assembly .....	15	- Parts .....	36
- Drive Shaft/Power Head .....	15	- Service .....	36
- Throttle Linkage and Ignition Leads .....	15	- ECHO Consumer Product Support .....	36
- Front Handle .....	16	- Warranty Card .....	36
Pre-Operation .....	17	- Additional or Replacement Manuals .....	36
- Fuel .....	17	- Manual Ordering Instructions .....	36
- Equipment .....	18		
- Determine Operation Area .....	19		
Operation .....	19		
- Starting Cold Engine .....	20		

Specifications, descriptions and illustrative material in this literature are as accurate as known at the time of publication, but are subject to change without notice. Illustrations may include optional equipment and accessories, and may not include all standard equipment.

## MANUAL SAFETY SYMBOLS AND IMPORTANT INFORMATION

Throughout this manual and on the product itself, you will find safety alerts and helpful, information messages preceded by symbols or key words. The following is an explanation of those symbols and key words and what they mean to you.



This symbol accompanied by the words **WARNING** and **DANGER** calls attention to an act or condition that can lead to serious personal injury to operator and bystanders.



The circle with the slash symbol means whatever is shown within the circle is prohibited.



### IMPORTANT

The enclosed message provides information necessary for the protection of the unit.

### NOTE

This enclosed message provides tips for use, care and maintenance of the unit.

## SAFETY

### DECALS

Locate these safety decals on your unit. The complete unit illustration found in the "DESCRIPTION" section, will help you locate them. Make sure the decals are legible and that you understand and follow the instructions on them. If a decal cannot be read, a new one can be ordered from your ECHO Dealer. See PARTS ORDERING instructions for specific information.

These decals are in English only:

#### *Shaft Decal*

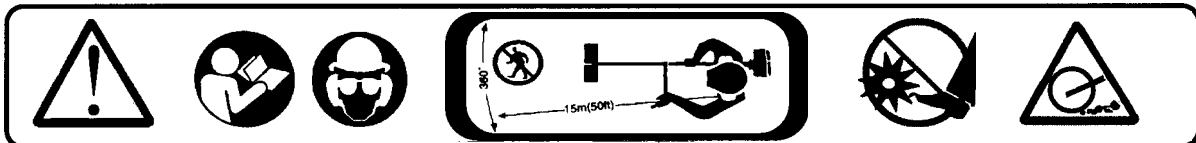

P/N 89016025560

#### **- WARNING - DANGER - ⚠**

• When used improperly this edger could cause serious personal injury. Read and follow all safety precautions in the owner's manual. • Never operate without eye protection. • Always inspect area for hidden or throwable objects. Never use in gravel. • Stay clear of rotating blade at all times. Keep bystanders at least 50' away. • Stop engine before adjusting cutting height or performing any service. • Never operate with unit positioned on left side of body. • Use only ECHO approved replacement blades on this unit. • Do not use edger blade on any brush cutter. • Edger attachment and blade are intended for edging only. • After replacing or servicing blade, arbors, nut and cotter pins must be assembled properly. P/N 89016052631

P/N 89016052631

## INTERNATIONAL SYMBOLS

Symbol form/ shape	Symbol description/ application	Symbol form/ shape	Symbol description/ application
	Read and understand Operator's Manual.		Fuel and oil mixture
	Wear eyes, ears and head protection		Finger Severing
	Hot Surface		Wear hand protection. Use two handed.
	Safety/Alert		DO NOT smoke near fuel.
	Avoid all power lines. This unit is not insulated against electrical current.		DO NOT allow flames or sparks near fuel.
			Keep bystanders away 15 m (50 ft.)

Symbol form/ shape	Symbol description/ application	Symbol form/ shape	Symbol description/ application
	Keep feet away from blade		Direction of blade
	Thrown objects		Emergency stop
	Wear slip resistant foot wear.		Engine choke control.
	Primer bulb		Ignition ON/OFF
	Carburetor adjustment - High speed mixture		Carburetor adjustment - Idle speed
	Carburetor adjustment - Low speed mixture		

## EQUIPMENT

Before operation a complete check of the unit must be performed;

- Check unit for loose/missing nuts, bolts and screws. Tighten and/or replace as needed. Do not use edger if any part is missing or damaged.
- Inspect fuel lines, tank and area around carburetor for fuel leaks. DO NOT operate unit if leaks are found.
- Inspect shield for damage and is **securely** in place. Replace if shield is damaged or missing.
- Check that the cutting attachment is firmly attached and in safe operating condition.



- Check that front handle is adjusted for safe, comfortable operation. See Assembly for proper adjustment.

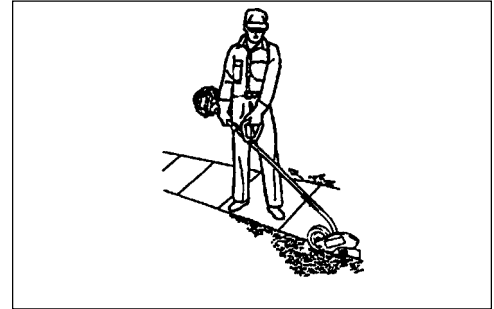

**WARNING**  **DANGER**

- Use only ECHO approved attachments. Serious injury may result from the use of a non approved attachment combination. Read and comply with all safety instructions listed in this manual and safety manual.
- ECHO, INC. will not be responsible for the failure of cutting devices, attachments or accessories which have not been tested and approved by ECHO.

**ATTACHMENTS  
AND  
ACCESSORIES**



***Spark Arrestor - Catalytic Muffler / Muffler***

- The muffler or catalytic muffler controls the exhaust noise and emissions. The spark arrestor screen prevents hot, glowing particles of carbon from leaving the muffler. Make sure the spark arrestor screen is in good repair and properly seated in the muffler. Keep exhaust area clear of flammable debris. Avoid contact during and immediately after operation.

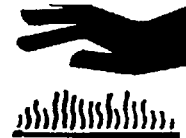

**FUEL**

**WARNING**  **DANGER**

Fuel is **VERY** flammable. Use extreme care when mixing, storing or handling or serious personal injury may result.

- Use an approved fuel container.
- DO NOT smoke near fuel.
- DO NOT allow flames or sparks near fuel.
- Fuel tanks/cans may be under pressure. Always loosen fuel caps slowly allowing pressure to equalize.
- NEVER refuel a unit when the engine is HOT!
- NEVER refuel a unit with the engine running.
- DO NOT fill fuel tanks indoors. ALWAYS fill fuel tanks outdoors over bare ground.
- Securely tighten fuel cap after refueling.
- Inspect for fuel leakage. If fuel leakage is found, do not start or operate unit until leakage is repaired.



std1

## IMPORTANT

Spilled fuel is a leading cause of hydrocarbon emissions. Some states may require the use of automatic fuel shut-off containers to reduce fuel spillage. Contact your ECHO dealer for ordering information.

### After Refueling:

- Wipe any spilled fuel from the unit.
- Move at least 3 m (10 ft.) from refueling location before starting.

### After use:

- DO NOT store a unit with fuel in its tank. Leaks can occur. Return unused fuel to an approved fuel storage container.

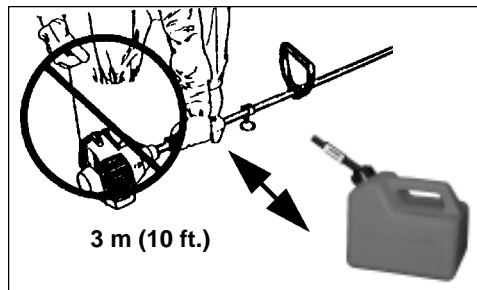

## PERSONAL CONDITION AND SAFETY EQUIPMENT

### WARNING DANGER

Edger users risk injury to themselves and others if the edger is used improperly and or safety precautions are not followed. Proper clothing and safety gear must be worn when operating an edger.

### *Physical Condition --*

Your judgment and physical dexterity may not be good:

- if you are tired or sick,
- if you are taking medication,
- if you have taken alcohol or drugs.

Operate unit only if you are physically and mentally well.



### *Eye Protection --*

Wear eye protection that meets ANSI Z87.1 or CE requirements whenever you operate the edger.



***Hand Protection --***

Wear no-slip, heavy duty work gloves to improve your grip on the edger handles. Gloves also reduce the transmission of machine vibration to your hands.

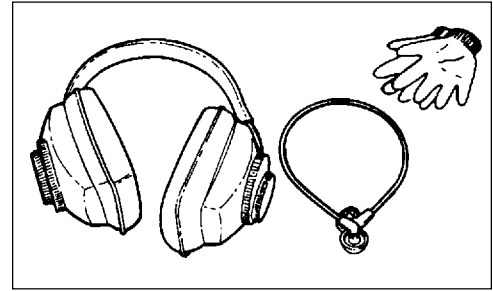

***Hearing Protection --***

ECHO recommends wearing hearing protection whenever unit is used.

***Proper Clothing --***

Wear snug fitting, durable clothing;

- Pants should have long legs, shirts with long sleeves.
- DO NOT WEAR SHORTS,
- DO NOT WEAR TIES, SCARVES, JEWELRY.



Wear sturdy work shoes with non-skid soles;

- DO NOT WEAR OPEN TOED SHOES,
- DO NOT OPERATE UNIT BAREFOOTED.

***Hot Humid Weather --***

Heavy protective clothing can increase operator fatigue which may lead to heat stroke. Schedule heavy work for early morning or late afternoon hours when temperatures are cooler.

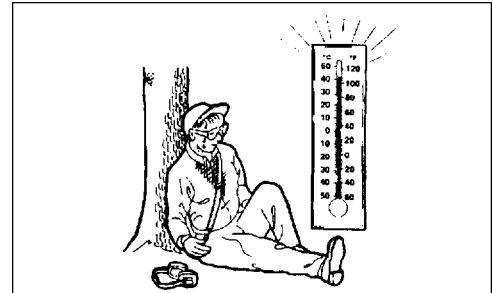

**SAFE OPERATION**

**Determine Operation Area**

- Provide all operators of this equipment with the Operator's Manual and instructions for safe operation.
- Review the area to be edged. Look for hazards that could contribute to unsafe conditions.
- Spectators and fellow workers must be warned, and children and animals prevented from coming nearer than 15 m (50 ft.) while the edger is in use.

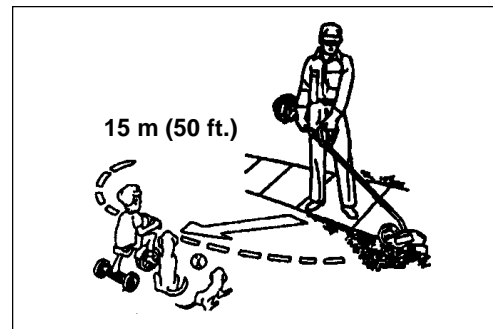

## Operation

### **WARNING** **DANGER**

Do not operate this product indoors or in inadequately ventilated areas. Engine exhaust contains poisonous emissions and can cause serious injury or death.



### **Use Proper Clothing & Equipment**

- Before starting the unit, equip yourself and any other person working within the 15 m (50 ft.) Safety Zone with the required Protective Equipment and clothing.

### **Keep A Firm Grip**

- Hold the front and rear handles with both hands with thumbs and fingers encircling the handles

### **Keep A Solid Stance**

- Maintain footing and balance at all times. Do not stand on slippery, uneven or unstable surfaces. Do not work in odd positions or on ladders. Do not over reach.

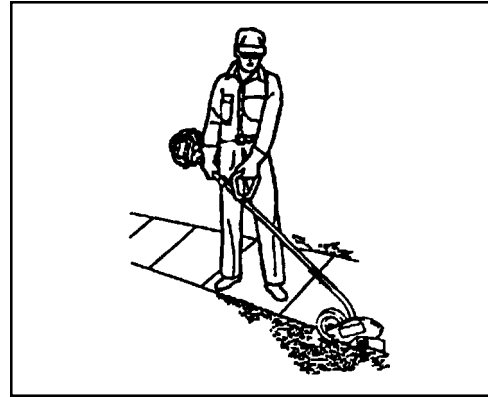

### **Avoid Hot Surfaces**

- During operation, the exhaust area may become very hot, too hot to touch. Avoid contact during and immediately after operation. Always keep exhaust area clear of flammable debris. Allow the engine and muffler to completely cool before performing any maintenance activity.

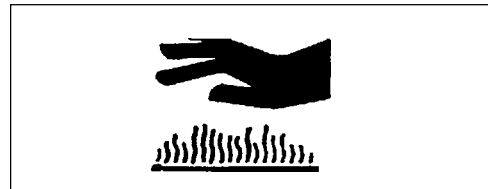



## **EXTENDED OPERATION/EXTREME CONDITIONS**

### ***Vibration and Cold --***

It is believed that a condition called Raynaud's Phenomenon, which affects the fingers of certain individuals may be brought about by exposure to vibration and cold. Exposure to vibration and cold may cause tingling and burning sensations followed by loss of color and numbness in the fingers. The following precautions are strongly recommended because the minimum exposure which might trigger the ailment is unknown.

- Keep your body warm, especially the head, neck, feet, ankles, hands and wrists.
- Maintain good blood circulation by performing vigorous arm exercises during frequent work breaks and also by not smoking.
- Limit the hours of operation. Try to fill each day with jobs where operating the edger or other hand-held power equipment is not required.
- If you experience discomfort, redness and swelling of the fingers followed by whitening and loss of feeling, consult your physician before further exposing yourself to cold and vibration.

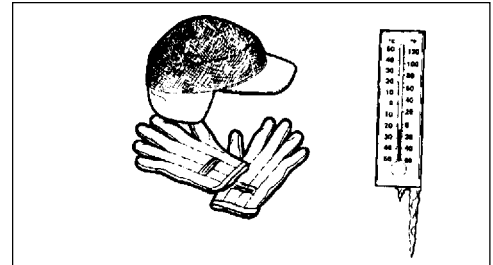

### ***Repetitive Stress Injuries --***

It is believed that overusing the muscles and tendons of the fingers, hands, arms and shoulders may cause soreness, swelling, numbness, weakness and extreme pain in those areas. Certain repetitive hand activities may put you at a high risk for developing a Repetitive Stress Injury (RSI). An extreme RSI condition is Carpal Tunnel Syndrome (CTS), which could occur when your wrist swells and squeezes a vital nerve that runs through the area. Some believe that prolonged exposure to vibration may contribute to CTS. CTS can cause severe pain for months or even years.

To reduce the risk of RSI/CTS, do the following:

- Avoid using your wrist in a bent, extended or twisted position. Instead try to maintain a straight wrist position. Also, when grasping, use your whole hand, not just the thumb and index finger.
- Take periodic breaks to minimize repetition and rest your hands.
- Reduce the speed and force with which you do the repetitive movement.
- Do exercises to strengthen the hand and arm muscles.
- Immediately stop using all power equipment and consult a doctor if you feel tingling, numbness or pain in the fingers, hands, wrists or arms. The sooner RSI/CTS is diagnosed, the more likely permanent nerve and muscle damage can be prevented.

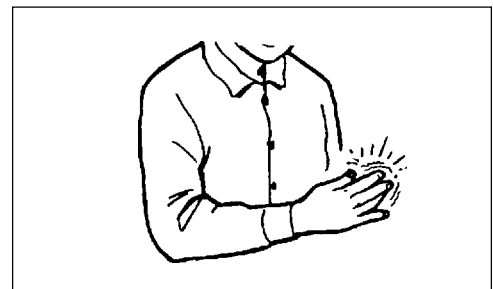
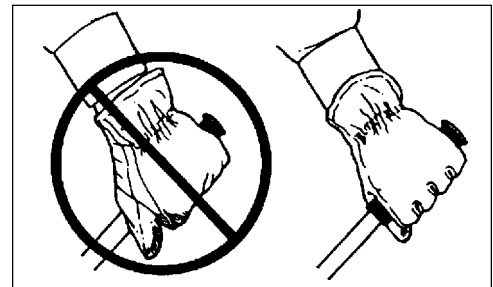

## DESCRIPTION

The ECHO product you purchased has been factory pre-assembled for your convenience. Due to packaging restrictions, shield installation and other assembly may be necessary.

After opening the carton, check for damage. Immediately notify your retailer or ECHO Dealer of damaged or missing parts. Use the contents list to check for missing parts.

## CONTENTS

- \_\_\_ 1, Edger Assembly
- \_\_\_ 1, Power Head
- \_\_\_ 1, Drive Shaft Assembly
- \_\_\_ 1, Plastic Bag (Co-Pack)
- \_\_\_ 1, Operator's Manual
- \_\_\_ 1, Safety Manual
- \_\_\_ 1, Warranty Registration Card
- \_\_\_ 1, ECHO Emissions and Warranty Statement
- \_\_\_ 1, 50:1 1 Gal. ECHO Oil Mix
- \_\_\_ 1, Front Handle
- \_\_\_ 4, 5X35 mm screws
- \_\_\_ 4, 5 mm nuts
- \_\_\_ 1, Srench (Combination Spark Plug Socket/Screwdriver)
- \_\_\_ 2, split pins
- \_\_\_ 1, 4 mm Hexagon Wrench
- \_\_\_ 1, Locking Tool
- \_\_\_ 1, 10 mm Spanner Wrench
- \_\_\_ Safety Glasses

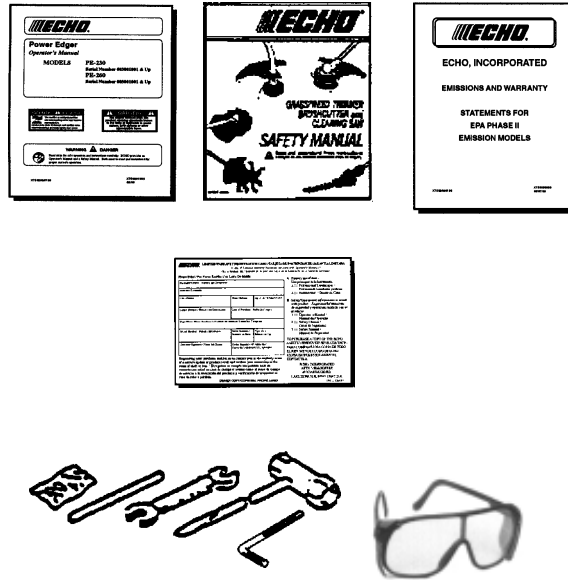



## EMISSION CONTROL

### *EPA Phase II*

The emission control system for these engines are EM (Engine Modification).

**IMPORTANT ENGINE INFORMATION**

ENGINE FAMILY: YEHXS.0254RA  
DISPLACEMENT: 25.4 cc  
THIS ENGINE MEETS U.S. EPA PHASE II EMISSION REGULATIONS FOR S.O.R.E. REFER TO OWNER'S MANUAL FOR MAINTENANCE SPECIFICATIONS AND ADJUSTMENTS.  
EMISSION COMPLIANCE PERIOD : 300 HRS.

 **KIORTZ CORP.** 

**An Emission Control Label** is located on the engine. (This is an EXAMPLE ONLY, information on label varies by engine FAMILY).

### PRODUCT EMISSION DURABILITY

The 300 hour emission durability period is the time span selected by the manufacturer certifying the engine emissions output meets applicable EPA emissions regulations, provided that approved maintenance procedures are followed as listed in the Maintenance Section of this manual.

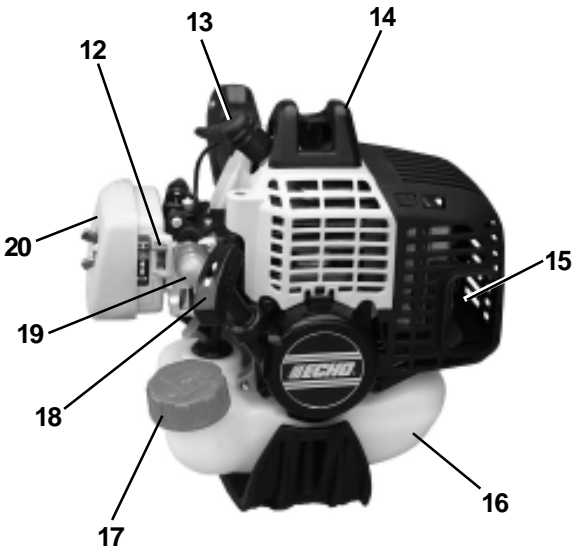

**PE-230**

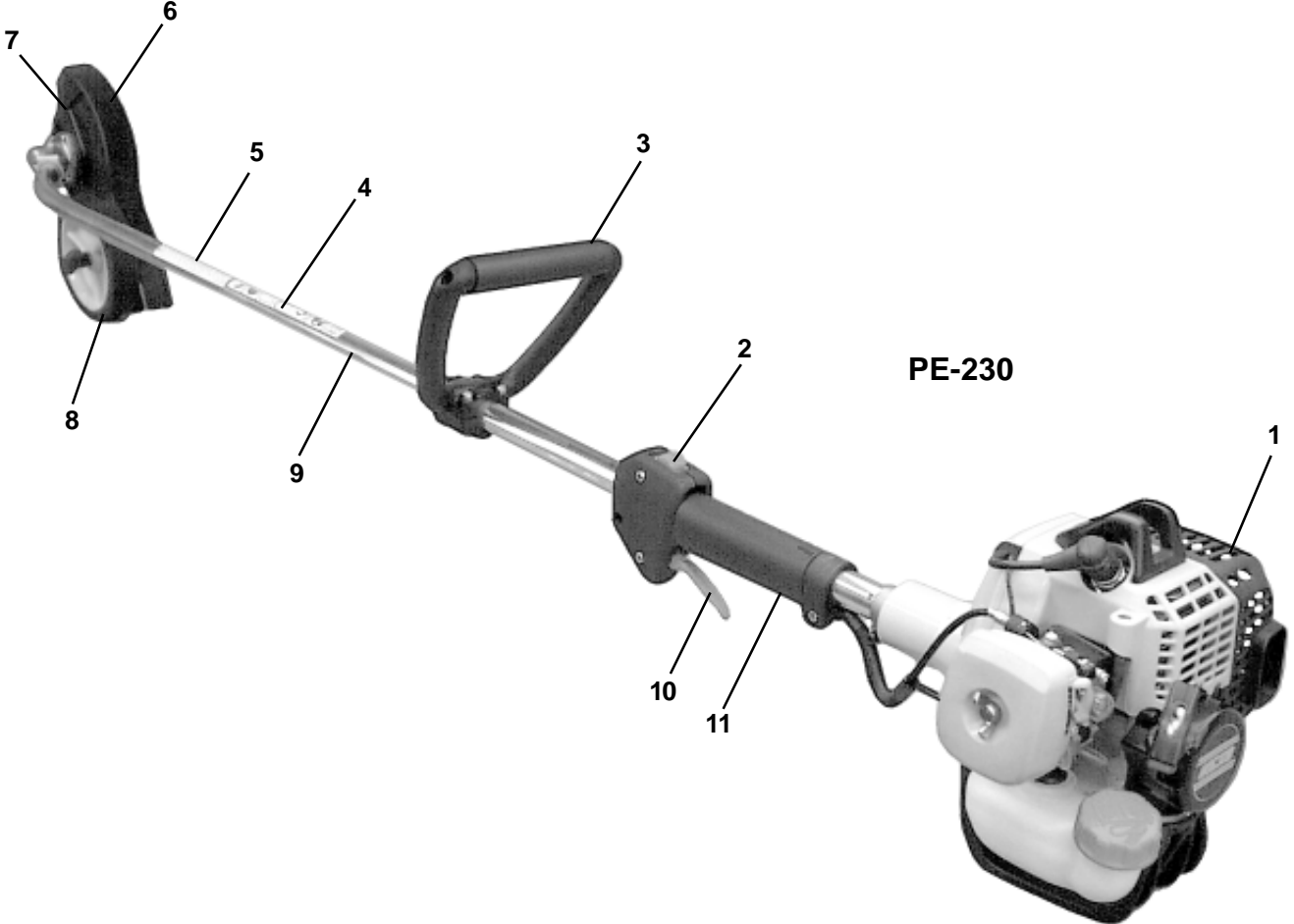
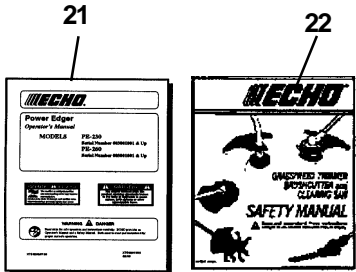

**PE-230**

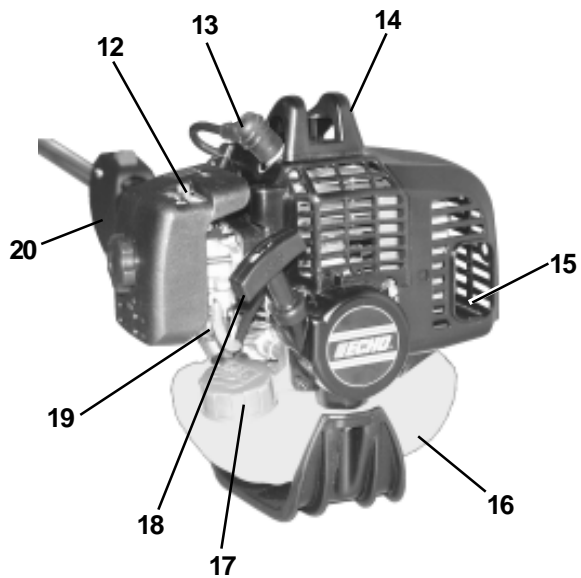

PE-260

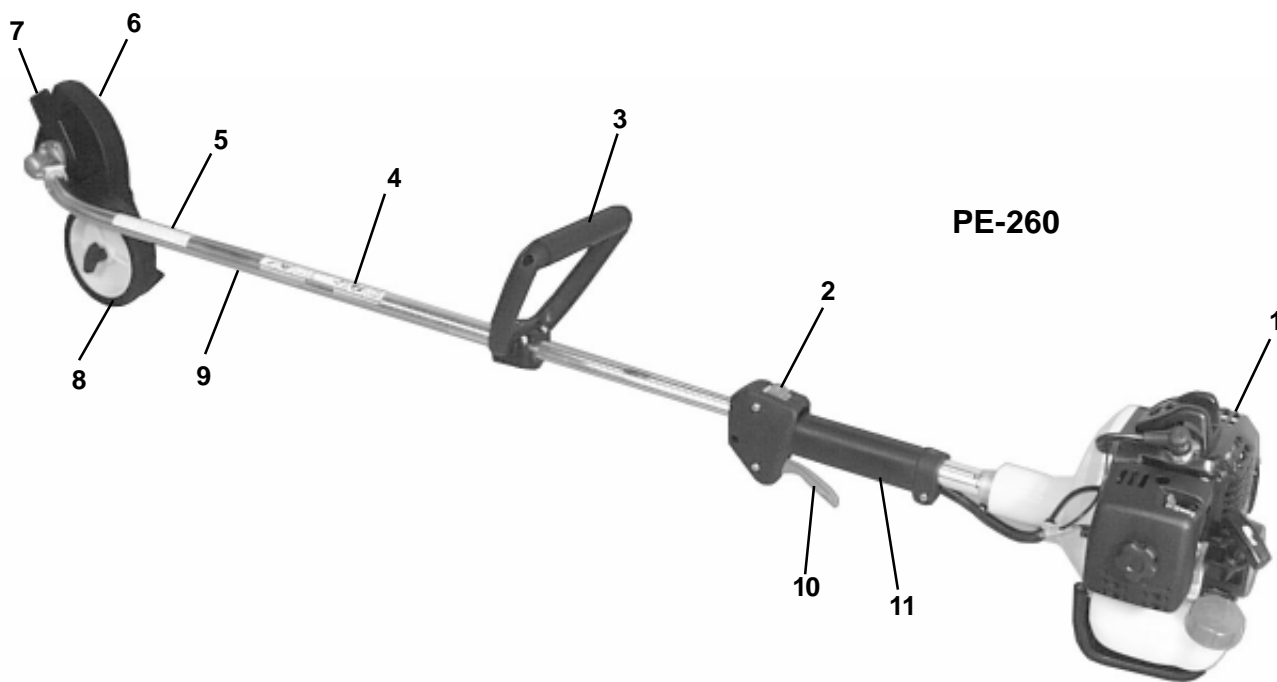
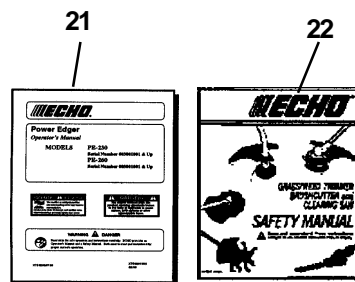

PE-260

1. **POWER HEAD** - Factory assembled. Includes the engine, clutch, fuel system, ignition system and starter.
2. **STOP SWITCH** - "Slide Switch" mounted on top of the throttle Trigger Housing. Move switch FORWARD to RUN, BACK to STOP.
3. **FRONT HANDLE** - The front handle can be repositioned for comfortable operation by loosening the screws and moving the handle.
4. **SHAFT DECAL** (See page 3)
5. **SHAFT DECAL** (See page 3)
6. **DEBRIS SHIELD/FLAP** - Mounted over the cutting attachment. Helps protect operator by deflecting debris produced during the edging operation.
7. **BLADE** - Rotates to provide cutting action.
8. **WHEEL** - Adjustable up/down, sets depth of blade.
9. **DRIVE SHAFT ASSEMBLY** - Contains a specially designed liner and the flexible drive shaft.
10. **THROTTLE TRIGGER** - Spring loaded to return to idle when released. When accelerating, press trigger gradually for best operating technique.
11. **GRIP** - Rear (right hand) handle.
12. **CHOKE** - The choke control is located on the top of the air filter case (PE-261); rear of the air filter case (PE-231). Move lever to "COLD START" to close choke for cold starting. Move lever to "RUN" position to open choke.
13. **SPARK PLUG** - Provides spark to ignite fuel mixture.
14. **ARM REST** - Provides arm rest during operation and protects arm from the hot engine.
15. **SPARK ARRESTOR - CATALYTIC MUFFLER / MUFFLER** -The muffler or catalytic muffler controls exhaust noise and emission. The spark arrestor screen prevents hot, glowing particles of carbon from leaving the muffler. Keep exhaust area clear of flammable debris.
16. **FUEL TANK** - Contains fuel and fuel filter.
17. **FUEL TANK CAP** - Cover and seals fuel tank.
18. **RECOIL STARTER HANDLE** - Pull recoil handle slowly until starter engages, then quickly and firmly. DO NOT let handle snap back or damage to unit will occur.
19. **PRIMER BULB** - Pumping primer bulb before starting engine draws fresh fuel from the fuel tank priming the carburetor for starting. Pump primer bulb until fuel is visible and flows freely in the clear fuel tank return line. Pump bulb an additional 4 or 5 times.
20. **AIR CLEANER ASSEMBLY** - Contains replaceable felt element.
21. **OPERATOR'S MANUAL** - Read and understand this manual before operation. Keep manual in a safe location for future reference, i.e., operation, maintenance, storage and specifications.
22. **SAFETY MANUAL** - Included in plastic bag (co-pack). Read before operation and keep in a safe place for future reference to learn proper, safe operating techniques.

## SPECIFICATIONS

MODEL	PE-230	PE-260
Length	1755 mm (69.1 in.)	
Width	315 mm (12.4 in.)	
Height	285 mm (11.2 in.)	
Weight (dry w/cutter head)	6.2 kg (13.8 lb.)	
Engine Type	Air cooled, two-stroke, single cylinder gasoline engine	
Bore	32.2 mm (1.27 in.)	34.0 mm (1.34 in.)
Stroke	28.0 mm (1.10 in.)	
Displacement	22.8 cc (1.39 cu. in.)	25.4 cc (1.55 cu. in.)
Exhaust	Spark Arrestor Muffler	
Carburetor diaphragm w/purge	Zama model RB	Walbro model WYJ
Ignition System	CDI (capacitor discharge ignition)	
Spark Plug	NGK BPM-7Y 0.65mm (0.026 in.)	
Fuel	Mixed (Gasoline and Two-stroke Oil)	
Fuel/Oil Ratio	50:1 ECHO High Performance, two-stroke air cooled engine oil	
Gasoline	89 Octane unleaded. DO NOT use fuel containing methyl alcohol, more than 10% ethyl alcohol or 15% MTBE.	
Oil	50:1 ECHO High Performance, two-stroke air cooled engine oil	
Fuel Tank Capacity	0.58 lit. (19.6 US fl. oz.)	
Recoil Starter System	Automatic Recoil Starter	
Clutch	Centrifugal Type	
Drive Shaft	6.35 mm (1/4 in.) flexible shaft	
Rotation Direction	Clockwise viewed from right side	
Edger Head	Metal blade	
Blade Length	203.2 mm (8.0 in.)	
Blade Width	50.8 mm (2 in.)	
Blade Thickness	2.3 mm (0.090 in.)	
Handle	Left Cushioned - D-loop, Right - Grip	
Vibration Reduction	Rubber Cushion	
Idle Speed (RPM)	2500 - 3100	
Wide Open Throttle Speed (RPM)	9000 - 12500	

## ASSEMBLY

### DRIVE SHAFT/POWER HEAD

*Tools Required:* 4mm Hex Wrench

*Parts Required:* Power Head, Drive Shaft Assembly

1. Loosen, the bolt (A) at engine drive shaft clamp.
2. Carefully fit drive shaft assembly to engine making sure that inner drive shaft engages into clutch mount.

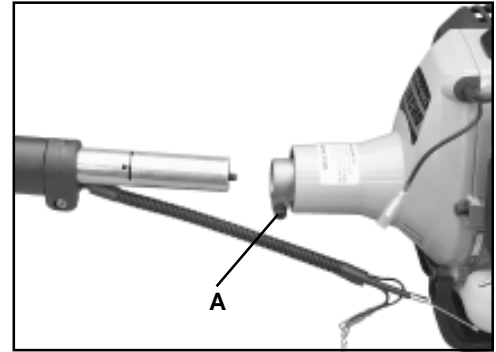

#### NOTE

Lower gear housing and head assembly must be in line with the engine.

3. Turn drive shaft housing so that center line of housing is midway between the two arrows on shaft.
4. Tighten bolt (A).

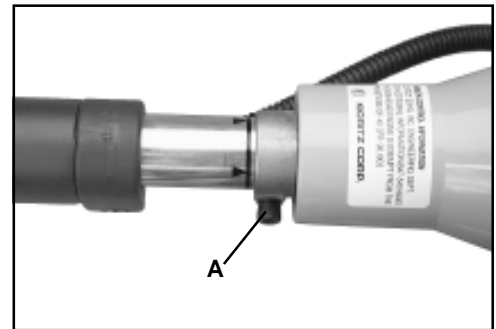

### THROTTLE LINKAGE AND IGNITION LEADS

#### PE-230

1. Connect ignition stop leads (A) and (B).
2. Place throttle linkage (C) through adjustment fixture (D) and install wire end into large carburetor throttle swivel hole (E). Check throttle for freedom of movement and that wide open throttle / low idle extremes are adjusted properly. The throttle linkage must be adjusted by moving the adjustment fixture (D). Consult with your Echo Dealer for correct adjustment procedure.
3. Bundle and secure ignition leads against engine housing with black clip (F).

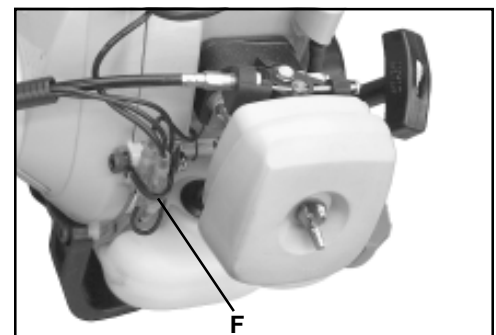
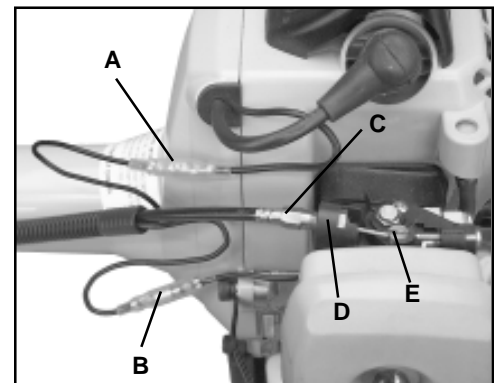

## THROTTLE LINKAGE AND IGNITION LEADS

### PE-260

1. Close choke and remove air filter cover.
2. Loosen nut (A) and place threaded end of throttle linkage in bracket slot. Finger tighten nut (A).
3. Place inner cable in slot of carburetor swivel (B) and tighten nut (A).
4. Check throttle for freedom of movement and that wide open throttle / low idle extremes are adjusted properly. If adjustment cannot be achieved with adjusting nuts, consult with your Echo Dealer for correct adjustment procedure.
5. Connect ignition stop leads (C) and (D).
6. Bundle and secure ignition leads against engine housing with clip (E).
7. Install air filter and cover.

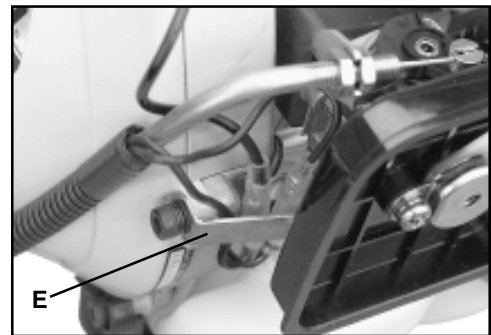
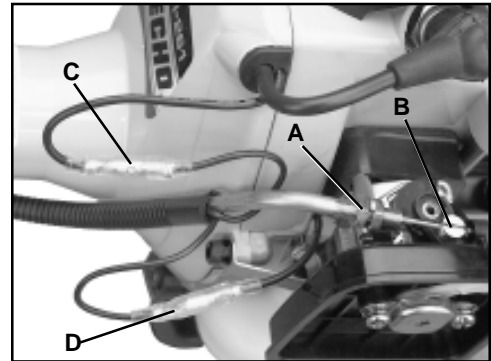

## FRONT HANDLE

*Tools Required: Cross-Head Screwdriver*

1. Assemble front handle and bracket loosely to drive shaft.
2. Position front handle in comfortable operating position and tighten screws.

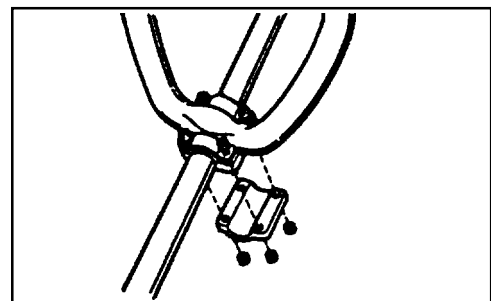



## PRE-OPERATION

### FUEL

#### Fuel Requirements

**Gasoline** - Use 89 Octane [ $\frac{R+M}{2}$ ] (mid grade or higher) gasoline known to be good quality. Gasoline may contain up to 15% MTBE (methyl tertiary-butyl ether). Gasohol containing methyl (wood) alcohol is **NOT** approved.

**Two Stroke Oil** - A two-stroke engine oil meeting ISO-L-EGD (ISO/CD 13738) and J.A.S.O. FC Standards, must be used. Echo brand Premium 50:1 oil meets this standard. Engine problems due to inadequate lubrication caused by failure to use an ISO-L-EGD and J.A.S.O. FC certified oil, such as Echo Premium 50:1 Two-stroke Oil, will void the two-stroke engine warranty. (Emission related parts only are covered for two years, regardless of two-stroke oil used, per the statement listed in the EPA Phase II Emission Defect Warranty Explanation.)

#### **IMPORTANT**

Echo Premium 2-Stroke Oil may be mixed at 50:1 ratio for application in all Echo engines sold in the past regardless of ratio specified in those manuals.

#### Mixing Instructions

1. Fill an approved fuel container with half of the required amount of gasoline.
2. Add 2-stroke oil to gasoline.
3. Close container and shake to mix oil with gasoline.
4. Add remaining gasoline and remix.
5. Install fuel container cap and wipe any spilled fuel from container and surrounding area.

#### Handling Fuel

#### **WARNING**



#### **DANGER**

Fuel is **VERY** flammable. Use extreme care when mixing, storing or handling, or serious personal injury may result.

- Use an approved fuel container.
- DO NOT smoke near fuel.
- DO NOT allow flames or sparks near fuel.
- Fuel tanks/cans may be under pressure. Always loosen fuel caps slowly allowing pressure to equalize.
- NEVER refuel a unit when the engine is HOT!
- NEVER refuel a unit with the engine running.
- DO NOT fill fuel tanks indoors. ALWAYS fill fuel tanks outdoors over bare ground.
- Securely tighten fuel cap after refueling.
- Inspect for fuel leakage. If fuel leakage is found, do not start or operate unit until leakage is repaired.

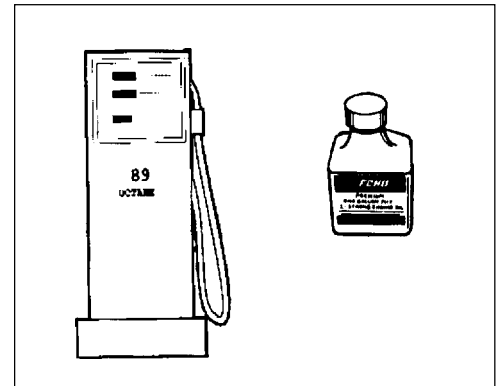

## IMPORTANT

Spilled fuel is a leading cause of hydrocarbon emissions. Some states may require the use of automatic fuel shut-off containers to reduce fuel spillage. Contact your ECHO dealer for ordering information.

### After refueling;

- Wipe any spilled fuel from the unit.
- Move at least 3 m (10 ft.) from refueling location before starting the engine.

### After use;

- DO NOT store a unit with fuel in its tank. Leaks can occur. Return unused fuel to an approved fuel storage container.

### Storage -

Fuel storage laws vary by locality. Contact your local government for the laws affecting your area. As a precaution, store fuel in an approved, air tight container. Store in a well ventilated, unoccupied building, away from sparks and flames. Do not store fuel longer than 30 days.

## IMPORTANT

Stored fuel ages. Do not mix more fuel than you expect to use in thirty (30) days, ninety (90) days when a fuel stabilizer is added.

## IMPORTANT

Stored two-stroke fuel may separate. ALWAYS shake fuel container thoroughly before each use.

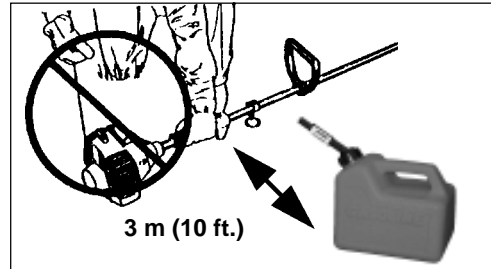

S	M	T	W	T	F	S
1	2	3	4	5	6	7
8	9	10	11	12	13	14
15	16	17	18	19	20	21
22	23	24	25	26	27	28
29	30	31				

## EQUIPMENT

Before operation a complete check of the unit must be performed;

- Check unit for loose/missing nuts, bolts and screws. Tighten and/or replace as needed. Do not use edger if any part is missing or damaged.
- Inspect fuel lines, tank and area around carburetor for fuel leaks. DO NOT operate unit if leaks are found.
- Inspect shield for damage and is **securely** in place. Replace if shield is damaged or missing.
- Check that the cutting attachment is firmly attached and in safe operating condition.
- Check that front handle is adjusted for safe, comfortable operation. See Assembly for proper adjustment.



## DETERMINE OPERATION AREA

### WARNING DANGER

Inspect starting area for hazards such as rocks, glass, debris etc. which could be contacted by the cutting attachment when starting. Keep helpers and bystanders at least 15 m (50 ft.) from starting area, otherwise serious personal injury may result.

- Before starting the unit, equip yourself and any other person working within the 15 m (50 ft.) Safety Zone with the required Protective Equipment and clothing.
- Spectators and fellow workers must be warned, and children and animals prevented from coming nearer than 15 m (50 ft.) while the edger is in use.

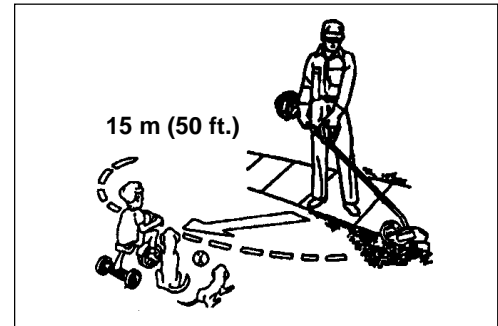

## OPERATION

### WARNING DANGER

Do not operate this product indoors or in inadequately ventilated areas. Engine exhaust contains poisonous emissions which can cause serious injury or death.

- Provide all operators of this equipment with the Operator's Manual and instructions for safe operation.
- During operation, the exhaust area may become very hot, too hot to touch. Avoid contact during and immediately after operation. Always keep exhaust area clear of flammable debris. Allow the engine and muffler to completely cool before performing any maintenance activity.

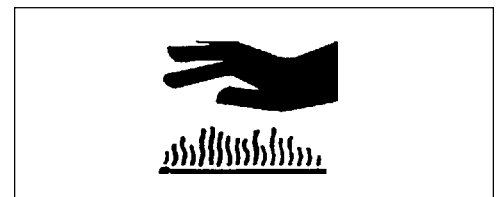
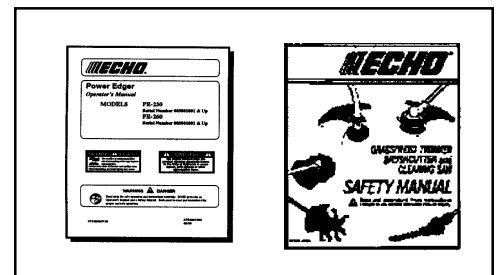

## STARTING COLD ENGINE

### WARNING DANGER

The cutting attachment should not rotate at idle. If attachment rotates, readjust carburetor according to "Carburetor Adjustment" instructions in this manual or see your ECHO Dealer, otherwise serious personal injury may result.

1. *Stop Switch - Start/Run.*  
Move stop switch button (A) forward away from the STOP position.
2. *Close Choke - Cold Start.*  
Move choke lever (B) to Cold Start Position.
3. *Primer - Pump Bulb.*  
Pump primer bulb (C) until fuel is visible in the "Clear" fuel return line. Pump bulb an additional 4 or 5 times.
4. *Start - Pull Rope.*  
Lay the edger on a flat clear area and pull the recoil starter handle (D) until engine fires.
5. *Open Choke - Run.*  
Move the choke lever to the "RUN" position. Restart engine if necessary and allow to warm up running at idle for several minutes.

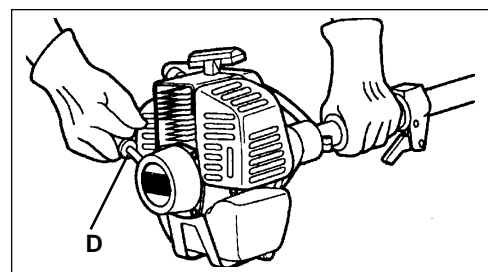
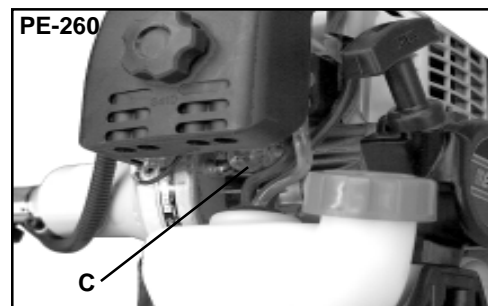
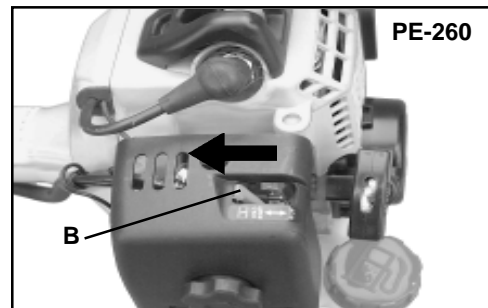
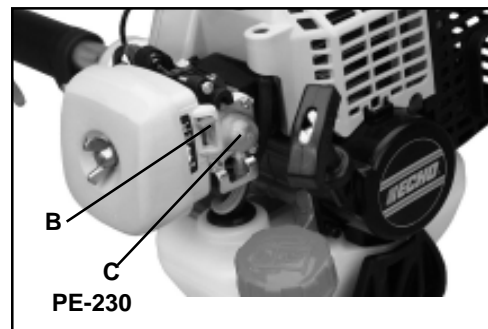
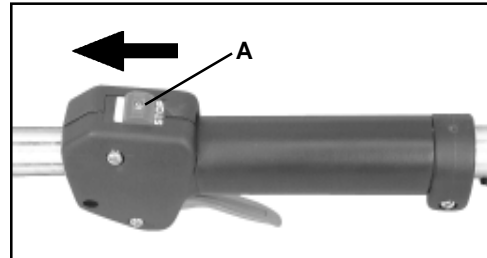

## STARTING WARM ENGINE

The starting procedure is the same as Cold Start except DO NOT close the choke.

### NOTE

If engine does not start after 5 pulls, use Cold Start Procedure.

## WARNING DANGER

When engine starts, the cutting attachment may rotate even with the throttle trigger in idle (released) position.

1. *Stop Switch - Start/Run.* Move stop switch button (A) away from the STOP position.

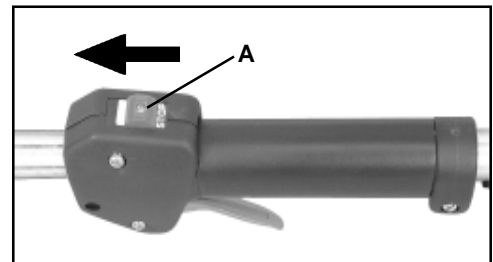

2. *Primer - Pump Bulb.* Pump primer bulb (C) until fuel is visible in the "Clear" fuel return line. Pump bulb an additional 4 or 5 times.

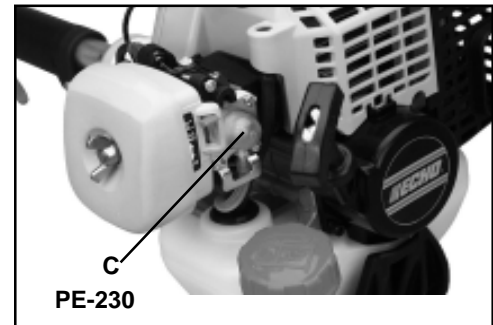

3. *Start - Pull Rope.* Lay the edger on a flat clear area and pull the recoil starter handle (D) until the engine fires.

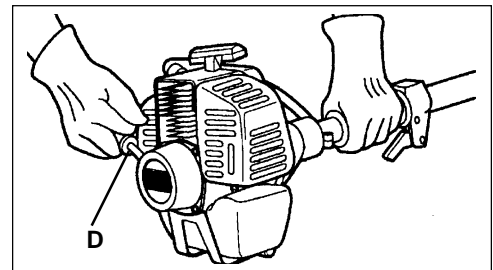
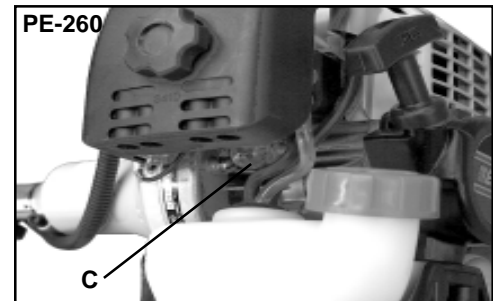

## STOPPING ENGINE

1. *Release Throttle.* Allow engine to idle for a minute.
2. *Stop Switch - Stop.* Move stop switch button (A) backward to STOP position.

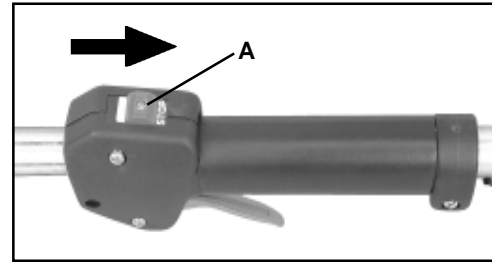

### WARNING DANGER

If engine does not stop when stop switch is moved to STOP position, close choke - COLD START position - to stall engine. Have your ECHO dealer repair stop switch before using edger again.

## OPERATING TECHNIQUES

1. Before edging, water the area to soften the ground to make edging easier.
2. Before edging, check the area and remove all obstacles and objects that could be thrown.
3. Plan to edge regularly to make it easier to keep a neat edge and to avoid having to make more than one pass.

### NOTE

Blade depth may have to be adjusted due to differences in height between the hard surface and the top of the grass.



### WARNING DANGER

Never adjust blade height with engine running, otherwise serious personal injury may result.

4. Adjust the blade's depth of cut to produce a fine cut between sidewalk and grass using a minimum blade depth, usually with about 13 mm (1/2 in.) of the blade into the ground.
5. Before edging, plan your direction of travel so that the unit will always be positioned on your right side and so that you walk on a hard surface whenever possible.
6. Hold edger as shown.

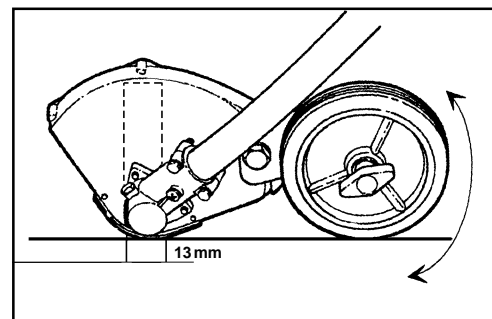

### WARNING DANGER

Before edging, be sure to read and understand the entire Operator's Manual to avoid the chance of serious injury.

7. When starting to edge, run the engine at full throttle, and lower the blade gently into the ground, being careful not to hit the concrete with the blade.
  
8. Don't force the blade. Move as quickly as the blade will allow.



**WARNING**  **DANGER**

The complete unit, specifically the drive shaft assembly and muffler exhaust area may become very hot during use. Avoid contact during and immediately after operation, otherwise serious personal injury may result.

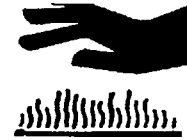

## MAINTENANCE

Your ECHO edger is designed to provide many hours of trouble free service. Regular scheduled maintenance will help your edger achieve that goal. If you are unsure or are not equipped with the necessary tools, you may want to take your unit to an ECHO Service Dealer for maintenance. To help you decide whether you want to DO-IT-YOURSELF or have the ECHO Dealer do it, each maintenance task has been graded. If the task is not listed, see your ECHO Dealer for repairs.

### SKILL LEVEL

- Level 1** = Easy to do. Most required tools come with unit.
- Level 2** = Moderate difficulty. Some specialized tools may be required.
- Level 3** = Experience required. Specialized tools are required. ECHO recommends that the unit be returned to your ECHO dealer for service.

ECHO offers **REPOWER™** Maintenance Kits and Parts to make your maintenance job easier. Just below each task heading are listed the various part numbers required for that task. See your ECHO dealer for these parts.

### MAINTENANCE INTERVALS

COMPONENT/ SYSTEM	MAINTENANCE PROCEDURE	REQ'D SKILL LEVEL	DAILY OR BEFORE USE	EVERY REFUEL	3 MONTHS OR 90 HOURS	6 MONTHS OR 270 HOURS	YEARLY 600 HOURS
<b>Recommended Echo Dealer Maintenance Procedures</b>							
Cylinder Exhaust Port	Inspect/Clean/Decarbon	<b>3</b>			<b>I / C</b>		
<b>Do-It-Yourself Maintenance Procedures</b>							
Air Filter	Inspect/Clean/Replace	<b>1</b>	<b>I / C</b>		<b>R*</b>		
Choke	Inspect/Clean	<b>2</b>	<b>I / C</b>				
Fuel Filter	Inspect/Replace	<b>1</b>			<b>I</b>		<b>R *</b>
Fuel System, leaks	Inspect/Replace	<b>1</b>	<b>I</b>	<b>I / R *</b>			
Cooling System	Inspect/Clean	<b>2</b>	<b>I / C</b>				
Muffler Spark Arrestor	Inspect/Replace	<b>2</b>	<b>I / C</b>		<b>I / R*</b>		
Drive Shaft	Grease	<b>2</b>			<b>I (1)</b>		
Gear Housing	Grease	<b>2</b>			<b>I (2)</b>		
Recoil Starter Rope	Inspect/Clean	<b>1</b>	<b>I / C *</b>				<b>I / R*</b>
Spark Plug	Inspect/Clean	<b>2</b>			<b>I / C</b>	<b>R *</b>	
Blade Replacement	Inspect/Replace	<b>1</b>	<b>I</b>	<b>I</b>	<b>I / R*</b>		
Screws/Nuts/Bolts	Inspect/Tighten/Replace	<b>1</b>	<b>I / R *</b>				

**MAINTENANCE PROCEDURE LETTER CODES:** I = INSPECT, R = REPLACE, C = CLEAN

**IMPORTANT NOTE** - Time intervals shown are maximum. Actual use and your experience will determine the frequency of required maintenance.

**MAINTENANCE PROCEDURE NOTES:**

(1) Apply ECHO® LUBE™ every 50 hours of use.

(2) Apply ECHO® LUBE™ every 15-25 hours of use.

\* All recommendations to replace are based on the finding of damage or wear during inspection..



## AIR FILTER

### Level 1.

*Tools required:* Cleaning brush, 25 or 50 mm (1 or 2 in.) medium bristle paint brush.

*Parts required:* (PE-230) 90008 REPOWER™ Air & Fuel Filter Kit.  
(PE-260) 90030 REPOWER™ Air & Fuel Filter Kit.

1. Close choke (Cold Start Position). This prevents dirt from entering the carburetor throat when the air filter is removed. Brush accumulated dirt from the air cleaner area.
2. Remove the air cleaner cover. Clean and inspect the element for damage. If element is fuel soaked and very dirty, replace.
3. If element can be cleaned and reused, be certain it:
  - still fits the cavity in the air cleaner cover.
  - is installed with the original side out.

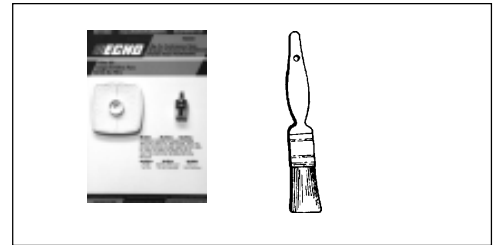

## FUEL FILTER

### Level 1.

*Tools required:* Fuel line hook, 203-254 mm (8-10 in.) length of wire with one end bent into a hook. Clean rag, funnel, and an approved fuel container.

*Parts required:* (PE-230) 90008 REPOWER™ Air & Fuel Filter Kit.  
(PE-260) 90030 REPOWER™ Air & Fuel Filter Kit.

**WARNING**  **DANGER**  
Fuel is **VERY** flammable. Use extreme care when mixing, storing or handling.

1. Use a clean rag to remove loose dirt from around fuel cap and empty fuel tank.
2. Use the “fuel line hook” to pull the fuel line and filter from the tank.
3. Remove the filter from the line and install the new filter.

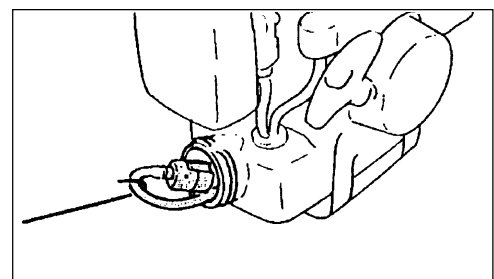

## WARNING DANGER

Catalytic mufflers operate at extremely high temperatures. Muffler area must be kept clean. Do not perform maintenance on the muffler until engine and muffler are completely cool, otherwise serious personal injury may occur.

## SPARK PLUG

### Level 2.

*Tools Required:* T-Wrench (combination socket wrench & screw driver supplied with unit) Feeler gauge, preferably a wire gauge. Soft Metal Brush.

*Parts Required:* (PE-230) 90064 REPOWER™ Tune-Up Kit  
(PE-260) 90065 REPOWER™ Tune-Up Kit

1. Remove spark plug and check for fouling, worn and rounded center electrode.
2. Clean the plug or replace with a new one. DO NOT sand blast to clean. Remaining sand will damage engine.
3. Adjust spark plug gap by bending outer electrode.
4. Tighten spark plug to 145-155 kg/cm (125-135 in. lb.).

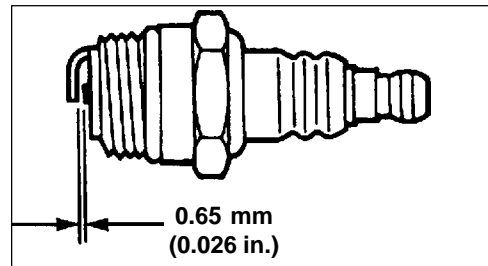
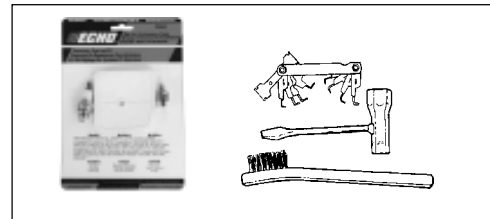

## COOLING SYSTEMS CLEANING

### Level 3.

*Tools required:* Cross Head Screwdriver, 4 mm Hex Wrench, Cleaning Brush, 25 or 50 mm (1 or 2 in.) medium bristle paint brush.

*Parts Required:* None if you are careful.

### IMPORTANT

To maintain proper engine operating temperatures, cooling air must pass freely through the cylinder fin area. This flow of air carries combustion heat away from the engine.

Overheating and engine seizure can occur when:

- Air intakes are blocked, preventing cooling air from reaching the cylinder.
- Dust and grass build up on the outside of the cylinder. This build up insulates the engine and prevents the heat from leaving.

Removal of cooling passage blockages or cleaning of cooling fins is considered "Normal Maintenance". Any failure attributed to lack of maintenance is not warranted.

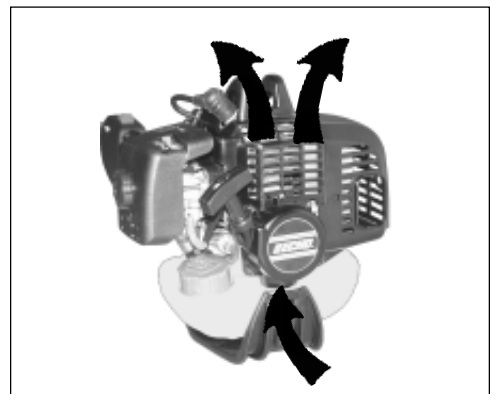
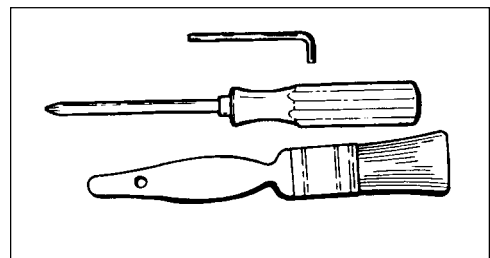

1. Remove spark plug lead.
2. Remove two (2) muffler cover screws and muffler cover (A).
3. Remove screw and arm rest (B).
4. Remove cylinder cover (C).

## IMPORTANT

DO NOT use a metal scraper to remove dirt from the cylinder fins.

5. Use brush to remove dirt from the cylinder fins.
6. Remove grass and leaves from the grid between the recoil starter and fuel tank.

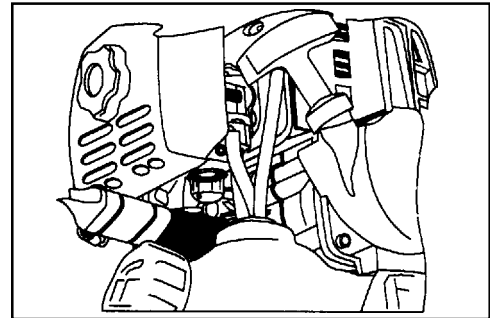
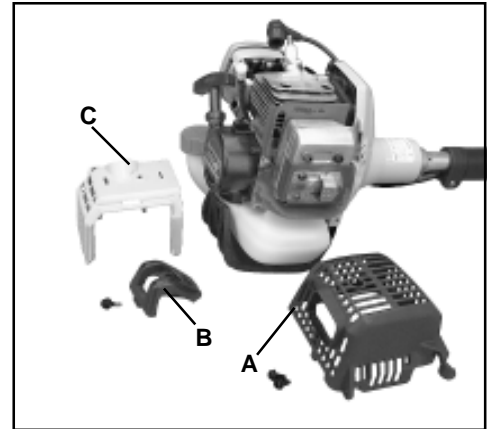

## EXHAUST SYSTEM

### Level 2.

*Tools Required:* Cross Head Screwdriver, 4mm Hex Wrench, Soft Metal Brush

*Parts Required:* Spark Arrestor Screen P/N 14586251030.

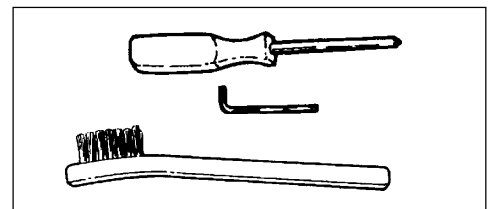

## *Spark Arrestor Screen*

1. Remove two (2) muffler cover screws and muffler cover (A).
2. Place piston at Top Dead Center (TDC) to prevent carbon/dirt from entering cylinder.
3. Remove spark arrestor screen cover (B), screen holder (C), gasket (D) and screen (E) from muffler body.
4. Clean carbon deposits from screen and muffler components.
5. Replace screen if it is cracked, plugged or has holes burned through.
6. Assemble components in reverse order.

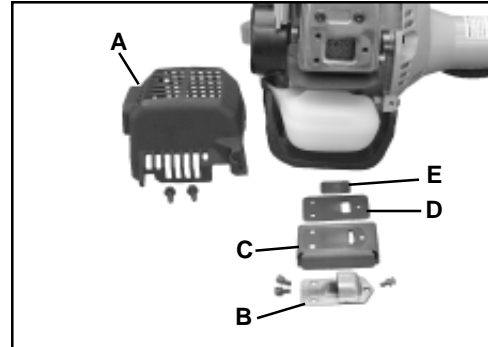

## *Cylinder Exhaust Port*

### Level 3.

#### **IMPORTANT**

The cylinder exhaust port must be inspected and cleaned of excess carbon every 3 months or 90 hours of operation in order to maintain this engine within the emissions durability period. ECHO strongly recommends that you return your unit to your ECHO dealer for this important maintenance service.

## **CARBURETOR ADJUSTMENT**

### *Engine Break-In*

New engines must be operated a minimum duration of two tanks of fuel break-in before carburetor adjustments can be made. During the break-in period your engine performance will increase and exhaust emissions will stabilize. Idle speed can be adjusted as required.

### *High Altitude Adjustment*

High altitude adjustment is not required for proper operation of this engine.

### Level 2.

*Tools required:* Screwdriver, Tachometer (ECHO P/N 99051130017).

*Parts required:* None.

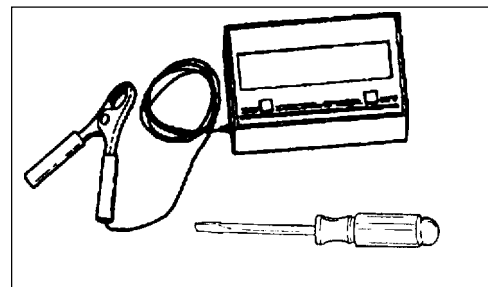

**NOTE**

Every unit is run at the factory and the carburetor is set in compliance with EPA Phase II Regulations. This carburetor does not have acceleration and high speed adjustment needles.

1. Check idle speed and reset if necessary. If a tachometer is available, idle speed screw (A) should be set to the specifications found on page 14 "Specifications" of this manual. Turn idle screw (A) clockwise to increase idle speed; counter clockwise to decrease idle speed.

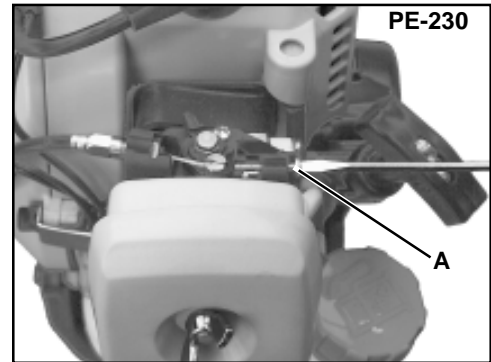

**WARNING**  **DANGER**

When carburetor adjustment is completed, the cutting attachment should not turn at idle, otherwise serious personal injury may result.

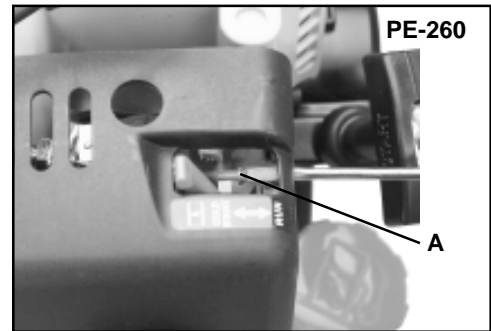

## BLADE REPLACEMENT/LUBRICATION

### Level 1.

*Tools Required:* Srench, Locking Tool, Needle Nose Pliers, 8 mm Open End Wrench

*Parts Required:* Echo Lube™ 8 oz. (P/N 91014) or Lithium Base Grease, Blade P/N 69601552632

**NOTE**

Grease gear case every 50 hours of use. Replace blade when it is worn shorter than 6 inches. Remove blade and holders before greasing to prevent damage to gear and bearings.

1. Shut engine off.
2. Remove split pin (A).
3. Rotate blade until holes in inner blade adapter (B) and gear box align. Insert locking tool supplied to lock PTO shaft (C).

**NOTE**

Shield cover not shown for illustration clarity.

**NOTE**

Blade nut (D) is left hand thread.

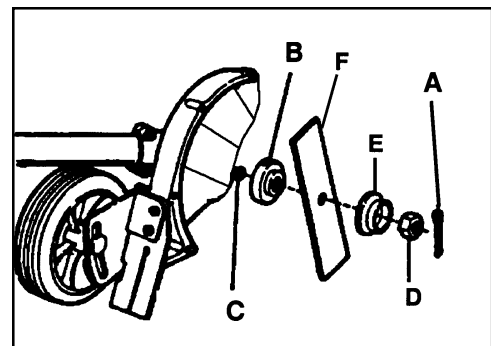
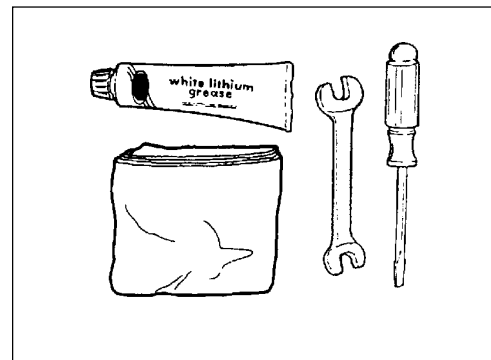

4. Remove blade nut (D) in a clockwise direction using box wrench supplied. Remove outer blade adapter (E), blade (F) and inner blade adapter (B).
5. Remove plug (G) and grease gear housing. Do not over fill - grease will emerge between PTO shaft (C) and seal when over full.

**NOTE**

Shield cover not shown for illustration clarity.

6. Install inner blade adapter (B) onto PTO shaft (C).
7. Install and center new blade (F) onto inner adapter (B).

8. Install outer adapter (E) and nut (D). Tighten nut (D) firmly, counterclockwise (CCW).

**IMPORTANT**

Never reuse old split pin.

9. Install new split pin (A) (#89850201130) to secure nut.

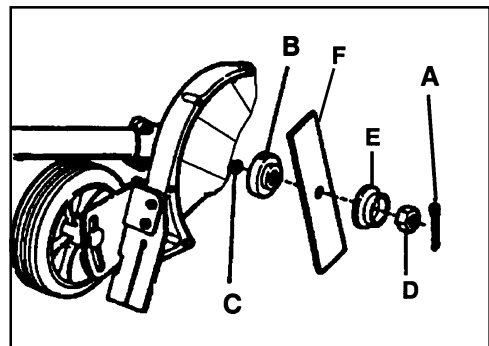
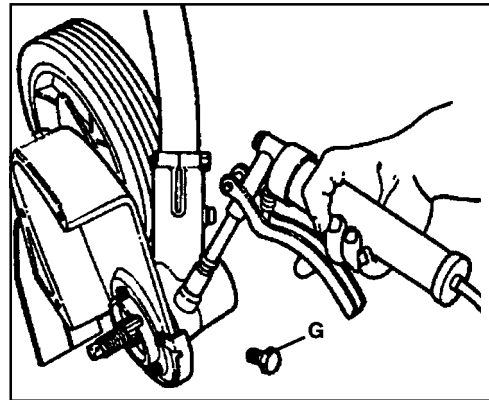
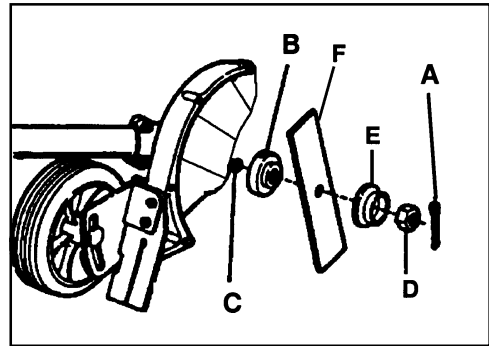

## TROUBLESHOOTING

Problem				
Engine -- starts hard				
Engine -- does not start			<b>Cause</b>	<b>Remedy</b>
Engine Cranks	Fuel at carburetor	No fuel at carburetor	Fuel strainer clogged Fuel line clogged Carburetor	Clean Clean See your ECHO dealer
	Fuel at cylinder	No fuel at cylinder	Carburetor	See your ECHO dealer
		Muffler wet with fuel	Fuel Mixture is too rich	Open choke Clean/replace air filter Adjust carburetor See your ECHO dealer
	Spark at end of plug wire	No spark at end of plug wire	Stop switch off Electrical problem Interlock switch	Turn switch on See your ECHO dealer See your ECHO dealer
	Spark at plug	No spark at plug	Spark gap incorrect Covered with carbon Fouled with fuel Spark plug defective	Adjust 0.65mm (0.026in.) Clean or replace Clean or replace Replace plug
Engine does not crank			Internal engine problem	See your ECHO dealer
Engine runs	Dies or accelerates poorly		Air filter dirty Fuel filter dirty Fuel vent plugged Spark plug Carburetor Cooling system plugged Spark arrestor screen plugged	Clean or replace Replace Replace Clean and adjust/replace Adjust Clean Clean

**WARNING**  **DANGER**

Fuel vapors are **extremely** flammable and may cause fire and/or explosion. **Never** test for ignition spark near an open spark plug opening, otherwise serious personal injury may result.

## STORAGE

### WARNING DANGER

During operation the muffler or catalytic muffler and surrounding cover become hot. Always keep exhaust area clear of flammable debris during transportation or when storing, otherwise serious property damage or personal injury may result.

### *Long Term Storage (over 30 days)*

Do not store your unit for a prolonged period of time (30 days or longer) without performing protective storage maintenance which includes the following:

1. Store unit in a dry, dust free place, out of the reach of children.

### WARNING DANGER

Do not store in enclosure where fuel fumes may accumulate or reach an open flame or spark.

2. Place the stop switch (A) in the "STOP" position.
3. Remove accumulation of grease, oil, dirt and debris from exterior of unit.
4. Perform all periodic lubrication and services that are required.
5. Tighten all the screws and nuts.
6. **Drain** the fuel tank **completely** and pull the recoil starter handle several times to remove fuel from the carburetor.
7. Remove the spark plug and pour 7 cc (1/4 oz.) (1/2 tablespoon) of fresh, clean, two-stroke engine oil into the cylinder through the spark plug hole.
  - A. Place a clean cloth over the spark plug hole.
  - B. Pull the recoil starter handle 2-3 times to distribute the oil inside the engine.
  - C. Observe the piston location through the spark plug hole. Pull the recoil handle slowly until the piston reaches the top of its travel and leave it there.
8. Install the spark plug (do not connect ignition cable).

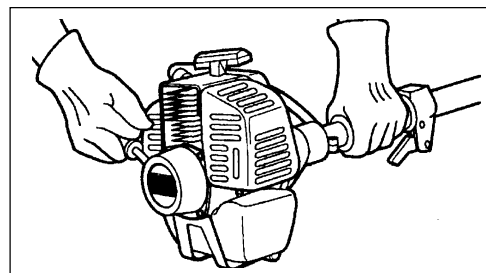
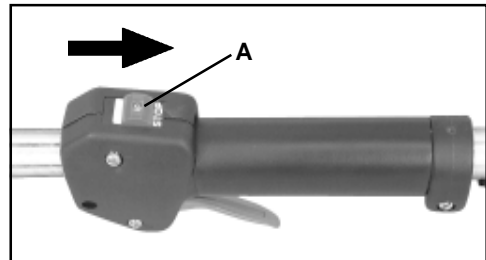



**NOTES**

**NOTES**

**NOTES**

# SERVICING INFORMATION

## PARTS

Genuine ECHO Parts and ECHO REPOWER™ Parts and Assemblies for your ECHO products are available only from an Authorized ECHO Dealer. When you do need to buy parts **always** have the Model Number and Serial Number of the unit with you. You can find these numbers on the engine housing. For future reference, write them in the space provided below.

Model No. \_\_\_\_\_ SN. \_\_\_\_\_

## SERVICE

Service of this product during the warranty period must be performed by an Authorized ECHO Service Dealer. For the name and address of the Authorized ECHO Service Dealer nearest you, ask your retailer or call: 1-800-432-ECHO (3246). Dealer information is also available on our Web Site. When presenting your unit for Warranty service/repairs, proof of purchase is required.

## ECHO CONSUMER PRODUCT SUPPORT

If you require assistance or have questions concerning the application, operation or maintenance of this product you may call the ECHO Consumer Product Support Department at 1-800-673-1558 from 8:00 am to 5:00 pm (Central Standard Time) Monday through Friday. Before calling, please know the model and serial number of your unit to help your Consumer Product Support Representative.

## WARRANTY REGISTRATION

You may register your Echo equipment using the warranty registration card or register on-line at [www.echo-usa.com](http://www.echo-usa.com). Registering provides a direct link between you and ECHO if we find it necessary to contact you.

## ADDITIONAL OR REPLACEMENT MANUALS

**Safety Manuals** in English/Spanish or English/French are available, free of charge, from your ECHO dealer or at [www.echo-usa.com](http://www.echo-usa.com).

**Operator's and Parts Manuals** are available by:

- Downloading free from [www.echo-usa.com](http://www.echo-usa.com)
- Purchasing from your Echo Dealer.
- Sending a check or money order for \$2.00 per Parts Catalog or \$1.50 per Operator's Manual made payable to ECHO, INCORPORATED. State on a sheet of paper the model number and serial number of the ECHO unit you have, part number of the manual (if known), your name and address and mail to address above.

**Safety Videos** are available from your Echo dealer. A \$5.00 shipping charge will be required for each video.

### Available Parts Catalog

PE-230 S/N 003001001 & UP  
PE-260 S/N 003001001 & UP

Part Number 99922203281  
Part Number 99922203282

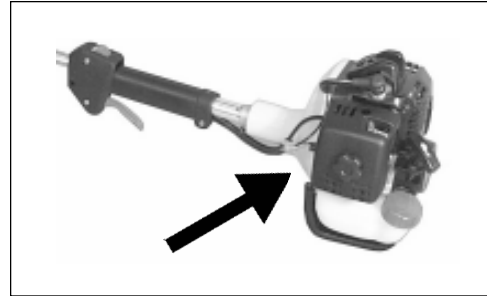

## DEALER?

Call  
**1-800-432-ECHO**  
or  
**[www.echo-usa.com](http://www.echo-usa.com)**

## CONSUMER PRODUCT SUPPORT

**1-800-673-1558**  
**8 - 5 Mon - Fri C.S.T.**

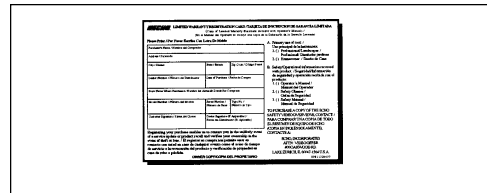

# **ECHO**®

**ECHO, INCORPORATED**

400 OAKWOOD ROAD  
LAKE ZURICH, IL 60047

**[www.echo-usa.com](http://www.echo-usa.com)**