



Tiller/Cultivator

Operator's Manual

MODEL

TC-2100 Type 1

Serial Number 011441 & Up

TC-2100 Type 1E

Serial Number 001001 & Up

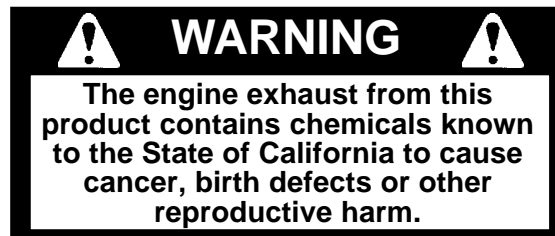

WARNING **DANGER**

Read rules for safe operation and instructions carefully. ECHO provides an Operator's Manual, which must be read and understood for proper and safe operation.

INTRODUCTION

Welcome to the ECHO family. This ECHO product was designed and manufactured to provide long life and on-the-job-dependability. Read and understand this manual that you found in the package. You will find it easy to use and full of helpful operations tips and SAFETY messages.

WARNING DANGER

Read rules for safe operation and instructions carefully. ECHO provides an Operator's Manual, which must be read and understood for proper and safe operation.

THE OPERATOR'S MANUAL --

contains specifications and information for operation, starting, stopping, maintenance, storage and assembly specific to this product.

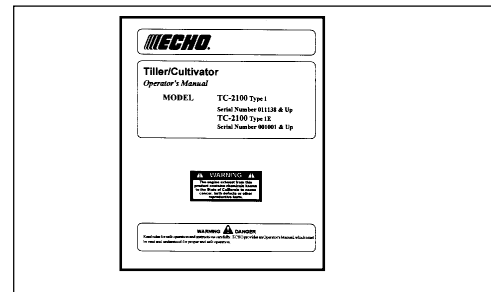

TABLE OF CONTENTS

Introduction	2	Maintenance	16
- The Operator's Manual	2	- Skill Levels	16
Manual Safety Symbols and Important Information	3	- Maintenance Intervals	16
Safety	3	- Air Filter	17
- General Description	3	- Fuel Filter	17
- Decals	4	- Spark Plug	18
- International Symbols	4	- Cooling System Cleaning	18
- Equipment	5	- Exhaust System	19
- Fuel	5	- Carburetor Adjustment Type 1E	20
- Personal Condition and Safety Equipment	6	- Carburetor Adjustment Type 1	21
- Safe Operation	7	- Lubrication	22
- Extended Operation/Extreme Conditions	7	Troubleshooting	23
Description	8	Storage	24
- Emission Control	8	Servicing Information	28
- Contents	8	- Parts	28
- Specifications	10	- Service	28
Assembly	11	- ECHO Consumer Product Support	28
Pre-Operation	12	- Warranty Card	28
- Fuel	12	- Additional or Replacement Manuals	28
- Equipment Check	13	- Manual Ordering Instructions	28
Operation	14		
- Starting Cold Engine	14		
- Starting Warm Engine	15		
- Stopping Engine	15		

Specifications, descriptions and illustrative material in this literature are as accurate as known at the time of publication, but are subject to change without notice. Illustrations may include optional equipment and accessories, and may not include all standard equipment.

SAFETY SYMBOLS AND IMPORTANT INFORMATION

Throughout this manual and on the product itself, you will find safety alerts and helpful, information messages preceded by symbols or key words. The following is an explanation of those symbols and key words and what they mean to you.



This symbol accompanied by the words **WARNING** and **DANGER** calls attention to an act or condition that can lead to serious personal injury to operator and bystanders.



The circle with the slash symbol means whatever is shown within the circle is prohibited.

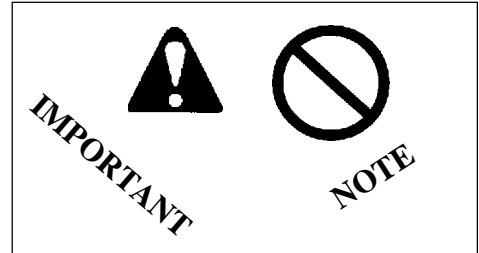

IMPORTANT The enclosed message provides information necessary for the protection of the unit.

NOTE This enclosed message provides tips for use, care and maintenance of the unit.

SAFETY

GENERAL DESCRIPTION

IMPORTANT

See Description and Specification sections for full description and illustration of model.

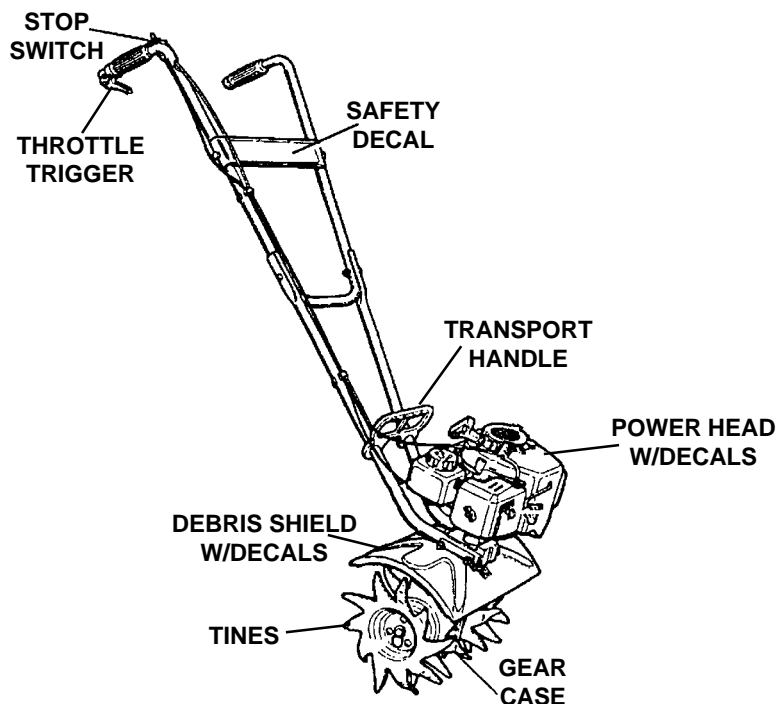

DECALS

Locate these safety decals on your unit. The complete unit illustration found in the "DESCRIPTION" section, will help you locate them. Make sure the decals are legible and that you understand and follow the instructions on them. If a decal cannot be read, a new one can be ordered from your ECHO dealer. See PARTS ORDERING instructions for specific information.

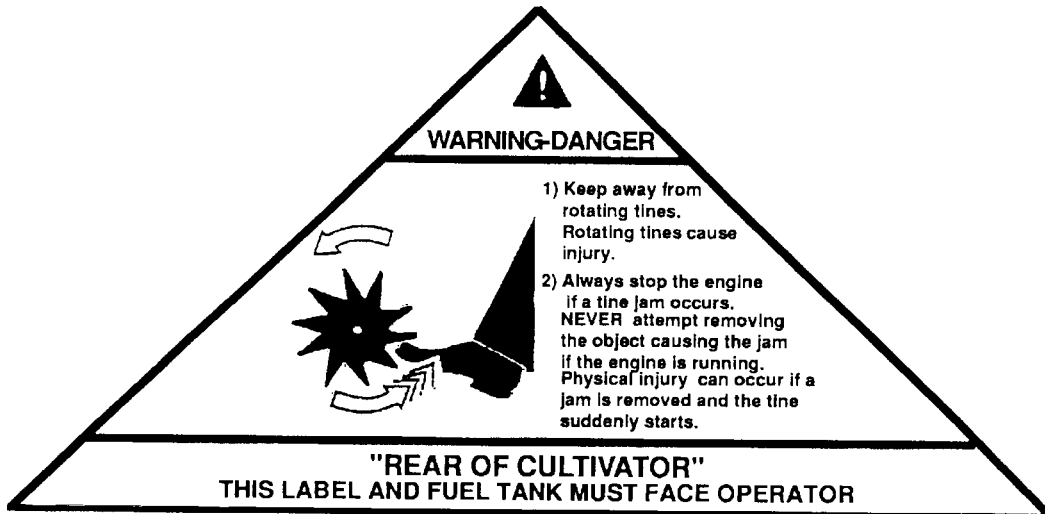
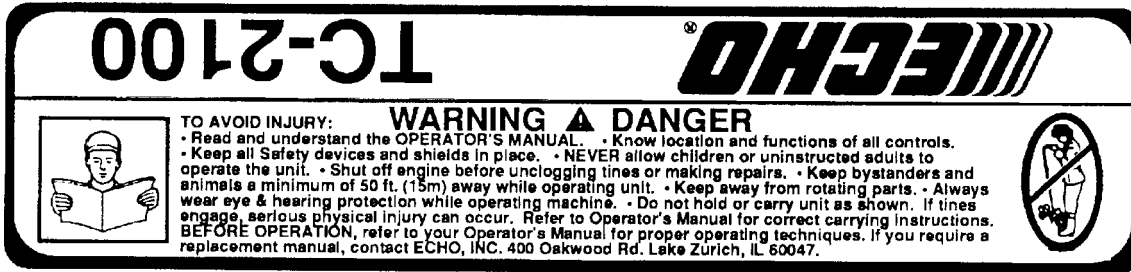

INTERNATIONAL SYMBOLS

Symbol form/shape	Symbol description/application	Symbol form/shape	Symbol description/application
	Read and understand Operator's Manual.		Fuel and oil mixture
	Wear eyes, ears and head protection		Finger Severing
	Hot Surface		Wear hand protection. Use two handed.
	Wear slip resistant foot wear.		DO NOT smoke near fuel.
	Safety/Alert		DO NOT allow flames or sparks near fuel.

Symbol form/shape	Symbol description/application	Symbol form/shape	Symbol description/application
	Avoid all power lines. This unit is not insulated against electrical current.		Emergency stop
	Engine choke control.		Ignition ON/OFF
	Primer bulb		Carburetor adjustment - High speed mixture
	Carburetor adjustment - Low speed mixture		Carburetor adjustment - Idle speed

EQUIPMENT

Before operation a complete check of the unit must be performed;

- Check unit for loose/missing nuts, bolts and screws. Tighten and/or replace as needed.
- Inspect fuel lines, tank and area around carburetor for fuel leaks. DO NOT operate unit if leaks are found.
- Inspect shield for damage and ensure that the shield is securely in place. Replace if shield is damaged or missing.
- Check that the tines are firmly attached and in safe operating condition.

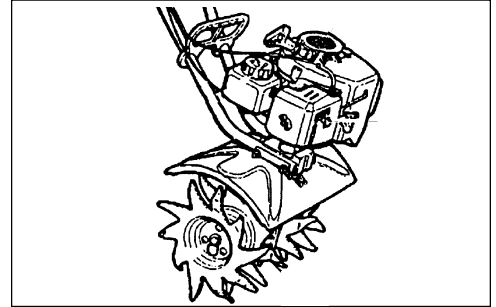
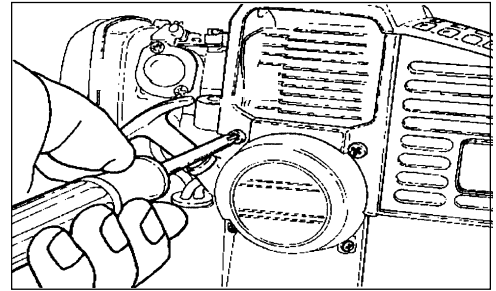

FUEL

WARNING DANGER

Fuel is **VERY** flammable. Use extreme care when mixing, storing or handling, or serious personal injury may result.

- Use an approved fuel container.
- DO NOT smoke near fuel.
- DO NOT allow flames or sparks near fuel.
- Fuel tanks/cans may be under pressure. Always loosen fuel caps slowly allowing pressure to equalize.
- NEVER refuel a unit when the engine is HOT!
- NEVER refuel a unit with the engine running.
- DO NOT fill fuel tanks indoors. ALWAYS fill fuel tanks outdoors over bare ground.
- Securely tighten fuel cap after refueling.
- Inspect for fuel leakage. If fuel leakage is found, do not start or operate unit until leakage is repaired.



IMPORTANT

Spilled fuel is a leading cause of hydrocarbon emissions. Some states may require the use of automatic fuel shut-off containers to reduce fuel spillage. Contact your ECHO dealer for ordering information.

After Refueling;

- Wipe any spilled fuel from the unit.
- Move at least 3 M (10 ft.) from refueling location before starting.

After Use;

- DO NOT store a unit with fuel in its tank. Leaks can occur. Return unused fuel to an approved fuel storage container.

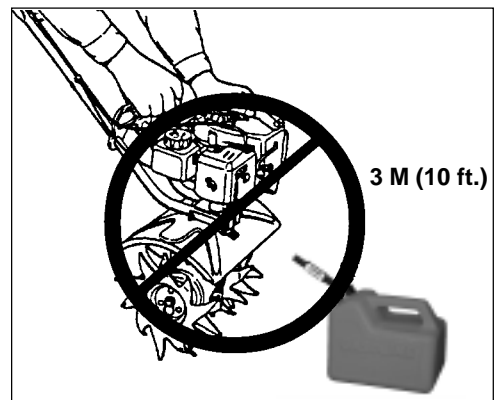

PERSONAL CONDITION AND SAFETY EQUIPMENT

WARNING DANGER

Tiller/Cultivator users risk injury to themselves and others if the tiller/cultivator is used improperly and or safety precautions are not followed. Proper clothing and safety gear must be worn when operating a tiller/cultivator. Failure to do so can result in serious injury.

Physical Condition --

Your judgment and physical dexterity may not be good:

- if you are sick,
- if you are taking medication,
- if you have taken alcohol or drugs.

Operate unit only if you are physically and mentally well.



Eye Protection --

Wear Eye protection that meet ANSI Z87.1 or CE requirements whenever you operate the tiller/cultivator.



Hand Protection --

Wear no-slip, heavy duty work gloves in improve your grip on the Tiller/Cultivator handles. Gloves also reduce the transmission of machine vibration to your hands.

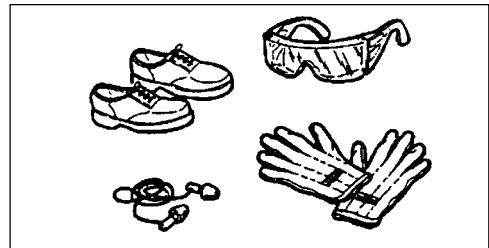

Hearing Protection --

ECHO recommends wearing hearing protection whenever unit is used.

Proper Clothing --

Wear snug fitting, durable clothing;

- Pants should have long legs, shirts with long sleeves.
- Wear hair covering to contain long hair.
- DO NOT WEAR SHORTS,
- DO NOT WEAR TIES, SCARFS, JEWELRY.

Wear sturdy work shoes with non-skid soles;

- DO NOT WEAR OPEN TOED SHOES,
- DO NOT OPERATE UNIT BAREFOOTED.

Wear no-slip, heavy duty work gloves.



Hot Humid Weather --

Heavy protective clothing can increase operator fatigue which may lead to heat stroke. Schedule heavy work for early morning or late afternoon hours when temperatures are cooler.

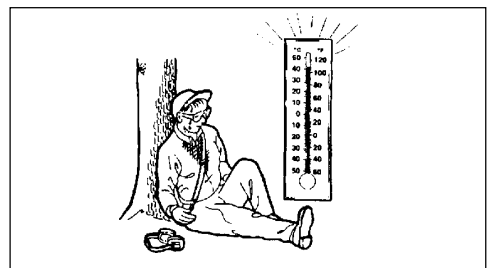

SAFE OPERATION

Determine Operation Area

- Provide all operators of this equipment with the Operator's Manual and instructions for safe operation.
- Review the area to be tilled. Look for hazards that could contribute to unsafe conditions.
- Spectators and fellow workers must be warned, and children and animals prevented from coming nearer than 15M (50 ft.) while the tiller/cultivator is in use.
- Do not operate this product indoors or in inadequately ventilated areas.

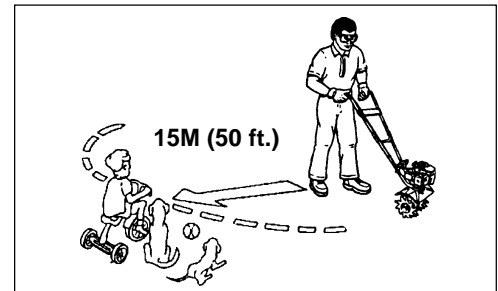

EXTENDED OPERATION/EXTREME CONDITIONS

Vibration and Cold --

It is believed that a condition called Raynaud's Phenomenon, which affects the fingers of certain individuals may be brought about by exposure to vibration and cold. Exposure to vibration and cold may cause tingling and burning sensations followed by loss of color and numbness in the fingers. The following precautions are strongly recommended because the minimum exposure which might trigger the ailment is unknown.

- Keep your body warm, especially the head, neck, feet, ankles, hands and wrists.
- Maintain good blood circulation by performing vigorous arm exercises during frequent work breaks and also by not smoking.
- Limit the hours of operation. Try to fill each day with jobs where operating the trimmer or other hand-held power equipment is not required.
- If you experience discomfort, redness and swelling of the fingers followed by whitening and loss of feeling, consult your physician before further exposing yourself to cold and vibration.

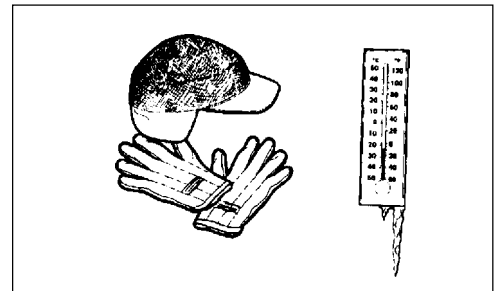

Repetitive Stress Injuries --

It is believed that overusing the muscles and tendons of the fingers, hands, arms and shoulders may cause soreness, swelling, numbness, weakness and extreme pain in those areas. Certain repetitive hand activities may put you at a high risk for developing a Repetitive Stress Injury (RSI). An extreme RSI condition is Carpal Tunnel Syndrome (CTS), which could occur when your wrist swells and squeezes a vital nerve that runs through the area. Some believe that prolonged exposure to vibration may contribute to CTS. CTS can cause severe pain for months or even years. To reduce the risk of RSI/CTS, do the following:

- Avoid using your wrist in a bent, extended or twisted position. Instead try to maintain a straight wrist position. Also, when grasping, use your whole hand, not just the thumb and index finger.
- Take periodic breaks to minimize repetition and rest your hands.
- Reduce the speed & force in which you do the repetitive movement.
- Do exercises to strengthen the hand and arm muscles.
- Immediately stop using all power equipment and consult a doctor if you feel tingling, numbness or pain in the fingers, hands, wrists or arms. The sooner RSI/CTS is diagnosed, the more likely permanent nerve and muscle damage can be prevented.

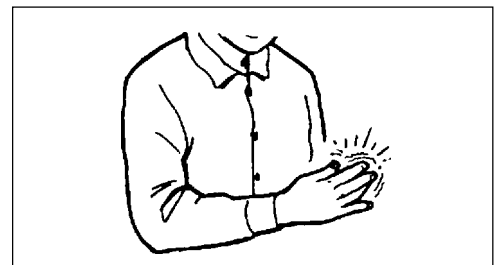
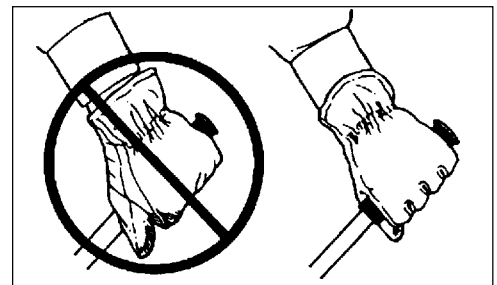

DESCRIPTION

The ECHO product you purchased has been factory pre-assembled for your convenience. Due to packaging restrictions some assembly is required.

After opening the carton, check for damage. Immediately notify your retailer or ECHO Dealer of damaged or missing parts. Use the contents list to check for missing parts.

EMISSION CONTROL -

Type 1E Models

The emission control system for this engine is EM (Engine Modification).

Emission Control Label (located on Engine) (EXAMPLE ONLY, information on label varies by FAMILY).

IMPORTANT ENGINE INFORMATION

ENGINE FAMILY : TEH021UB24RA
 DISPLACEMENT : 21.2cc
 THIS ENGINE MEETS U.S. EPA PHI AND 1995 - 1999 CALIFORNIA EMISSION REGULATIONS FOR ULGE ENGINES. REFER TO OWNER'S MANUAL FOR MAINTENANCE SPECIFICATIONS AND ADJUSTMENTS.

E **KOHATZ CORP.**

CONTENTS LIST

- | | |
|-----------------------------------------------|--------------------------------------------------|
| ___ 1 - Power Head & Shield Assembly | ___ - Carry Handle |
| ___ 1 - Upper Handle Assembly | ___ - Cable Tie |
| ___ 1 - Left Lower Handle | ___ - Operator's Manual |
| ___ 1 - Right Lower Handle | ___ - Hardware Bag |
| ___ 2 - Lower Handle Mounting Brackets | ___ - 2, 10mm x 30mm Carriage Bolt |
| ___ 1 - Plastic Bag (Co-Pack) | ___ - 2, 10mm nut |
| ___ - 1, 1/4" x 3" Hex Head Shoulder Bolt | ___ - 2, 10mm Lock Washer |
| ___ - 1, 1/4" x 3-1/4" Hex Head Shoulder Bolt | ___ - Warranty Card & Limited Warranty Statement |
| ___ - 2, 1/4" Lock Washers | ___ - Bottle 2-Cycle Engine Oil |
| ___ - 2, 1/4" Lock Nuts | |

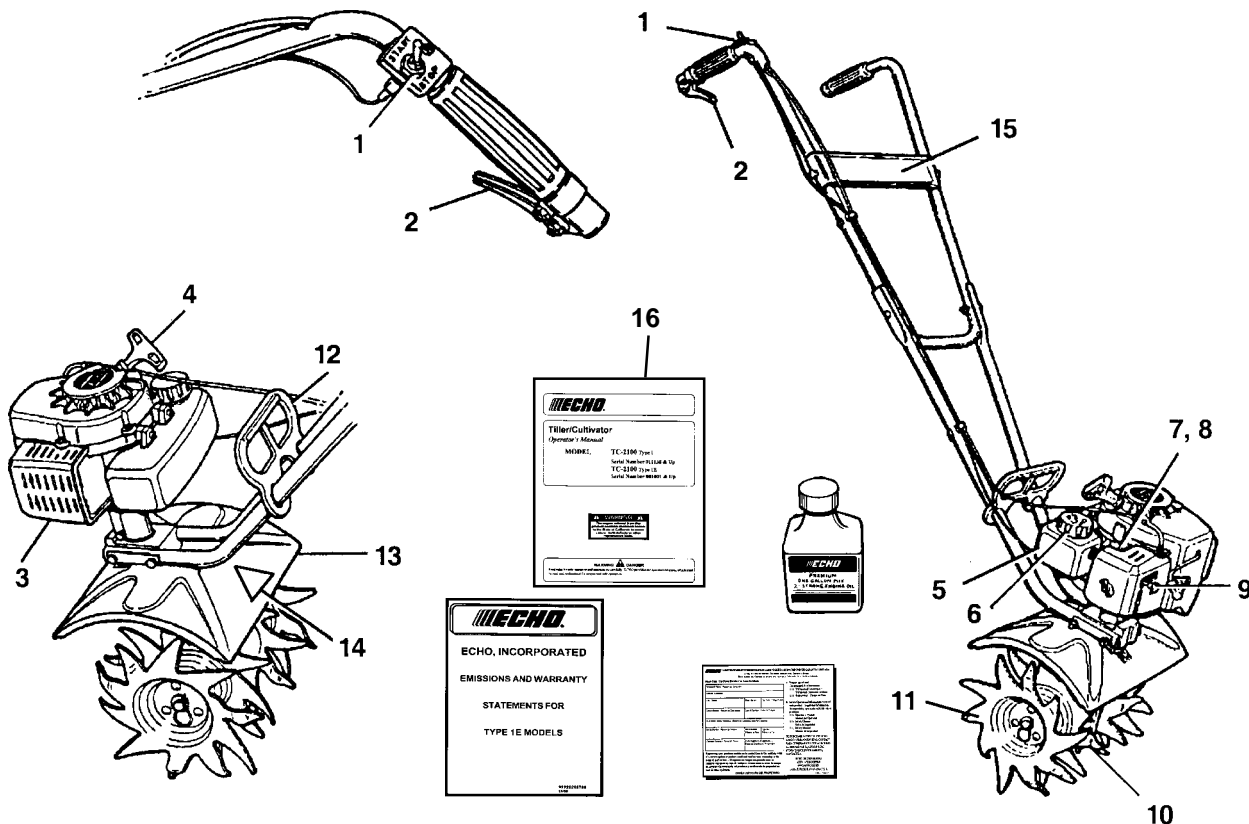

1. **STOP SWITCH** - "Toggle Switch" mounted on top of Throttle Trigger Housing. Move switch Forward to Run, Back to Stop.
2. **THROTTLE TRIGGER** - Spring loaded to return to idle when released. When accelerating, pull trigger gradually for best operating technique. **DO NOT** hold trigger when starting.
3. **MUFFLER/SPARK ARRESTOR** - The muffler controls the exhaust noise while the spark arrestor prevent hot, flowing particles of carbon from leaving the muffler where they could possibly start a fire.
4. **RECOIL STARTER HANDLE** - Pull recoil handle slowly until starter engages, then pull quickly and firmly. When engine starts, return handle slowly. **DO NOT** let handle snap back or damage to unit will occur.
5. **FUEL TANK** - Contains fuel and fuel filter.
6. **FUEL TANK CAP** - Cover and seals fuel tank opening.
7. **PRIMER BULB** - Before starting and after filling the fuel tank, pump primer bulb 10 times or until a steady stream of fresh fuel is visible through the "clear" fuel return line.
8. **AIR CLEANER** - Contains replaceable filter element.
9. **CHOKE** - The choke control is located on the side of the air filter case. Move choke to "COLD START" to close the choke for cold starting. Move choke to "RUN" position to open choke.
10. **GEAR BOX** - Houses gears for driving tines.
11. **TINES** - Used to till or cultivate soil. Removable for cleaning.
12. **CARRYING HANDLE** - Use for convenient transportation.
13. **TINE GUARD** - Used to help deflect debris away from operator and reduce accidental contact of tines.
14. **SAFETY DECAL** - See Description on Page 4.
15. **SAFETY DECAL** - See Description on Page 4.
16. **OPERATOR'S MANUAL** - Read and understand this manual before operation. Keep manual in a safe location for future reference, i.e., operation, maintenance, storage and specifications.

SPECIFICATIONS

MODEL	TC-2100
Length	1130 mm (44.48 in.)
Width	340 mm (13.36 in.)
Height	1010 mm (39.76 in.)
Weight (dry) w/Tines	8.62 kg (19 lb.)
Engine Type	Air cooled, two-stroke, single cylinder gasoline engine
Bore	32.2 mm (1.268 in.)
Stroke	26.0 mm (1.04 in.)
Displacement	21.2 cc (1.29 cu. in.)
Exhaust	Spark Arrestor Muffler
Carburetor	Zama diaphragm model C1U w/pprimer bulbs
Ignition System	Flywheel magneto, capacitor discharge ignition type
Spark Plug	NGK BPM-7Y Gap 0.65 mm (0.026 in.)
Fuel	Mixed (Gasoline and Two-stroke Oil)
Fuel/Oil Ratio	50:1 ECHO High Performance, two-stroke air cooled engine oil
Gasoline	89 Octane unleaded. DO NOT use fuel containing methyl alcohol, more than 10% ethyl alcohol or 15% MTBE.
Oil	50:1 ECHO High Performance, two-stroke air cooled engine oil
Fuel Tank Capacity	0.5 lit. (17.0 US fl. oz.)
Recoil Starter System	Automatic Rewind Starter
Clutch	Centrifugal Type
Gear Case	Worm Gear Type (42:1 Ratio)
Tines	Special 10 Tooth Design
	•229 mm (9") Cultivating swath 1/4 tines
	•229 mm (9") Diameter
Idle Speed	3000 +/- 250 RPM
Wide Open Throttle Speed (W.O.T.)	11000 - 12000 RPM

ASSEMBLY

Tools Required: (2) 11mm (7/16in.) Wrenches

1. Support powerhead assembly upright on tines. Place top handle assembly to rear.
2. Loosley assemble lower handles using 6.35 x 76mm (1/4in. x 3in.) hex head shoulder bolt (A), lockwasher (B), and locknut (C) in front handle end mounting hole as shown.
3. Slide open end of lower handle assembly, front to rear, beneath powerhead and throttle linkage/ignition wires.
4. Place handle tubes into gearcase handle mounting grooves and assemble using 6.35 x 82.5mm (1/4in. x 3-1/4in) hex head shoulder bolt (D), lockwasher (B), and locknut (C) in rear handle mounting holes. **DO NOT TIGHTEN BOLTS.**
5. Slide carry handle onto lower handle tubes.
6. Place top handle assembly between lower handles, align mounting holes and install (2) 10 x 30mm carriage bolts (E), (2) lockwashers (F), and (2) nuts (G). Carriage bolts should be installed from the outside through the lower handle then upper handle tube.
7. Securely tighten lower handle bolts first, then the upper handle bolts.
8. Secure throttle linkage and stop switch lead midway on right lower handle with cable tie.

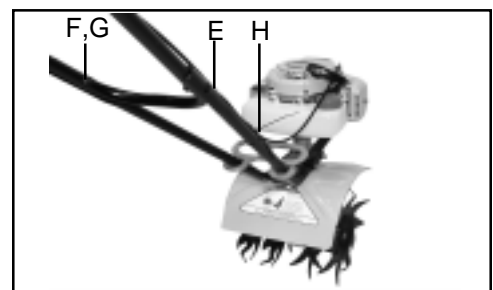
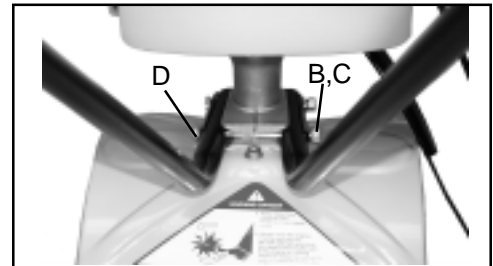
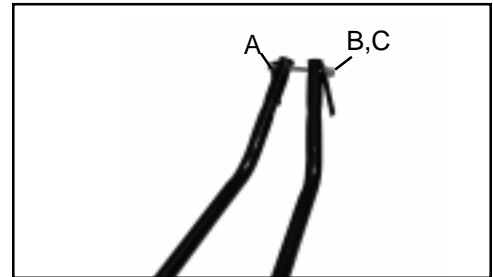

PRE-OPERATION

FUEL

Fuel Requirements

Gasoline - Use 89 Octane [R_{+M} ₂] gasoline or gasohol known to be good quality. Gasohol may contain up to 10% Ethyl (grain) alcohol or 15% MTBE (methyl tertiary-butyl ether). Gasohol containing methanol (wood alcohol) is **NOT** approved.

Two-Stroke Oil - A two-stroke engine oil meeting ISO-L-EGD Standard (ISO/CD 13738), must be used. Echo brand Premium 50:1 oil meets this standard. Engine problems due to inadequate lubrication caused by failure to use an ISO-L-EGD approved oil, such as Echo Premium 50:1 Two-stroke Oil, will void the two-stroke engine warranty. (Emission related parts only are covered for two years, regardless of two-stroke oil used, per the statement listed in the EPA Phase I/ California Emission Defect Warranty Explanation.)

Mixing - Follow directions on the oil container.

Handling Fuel

WARNING DANGER

Fuel is **VERY** flammable. Use extreme care when mixing, storing or handling or serious personal injury may result.

- Use an approved fuel container.
- DO NOT smoke near fuel.
- DO NOT allow flames or sparks near fuel.
- Fuel tanks/cans may be under pressure. Always loosen fuel caps slowly allowing pressure to equalize.
- NEVER refuel a unit when the engine is HOT!
- NEVER refuel a unit with the engine running.
- DO NOT fill fuel tanks indoors. ALWAYS fill fuel tanks outdoors over bare ground.
- Securely tighten fuel cap after refueling.
- Inspect for fuel leakage. If fuel leakage is found, do not start or operate unit until leakage is repaired.

IMPORTANT

Spilled fuel is a leading cause of hydrocarbon emissions. Some states may require the use of automatic fuel shut-off containers to reduce fuel spillage. Contact your ECHO dealer for ordering information.

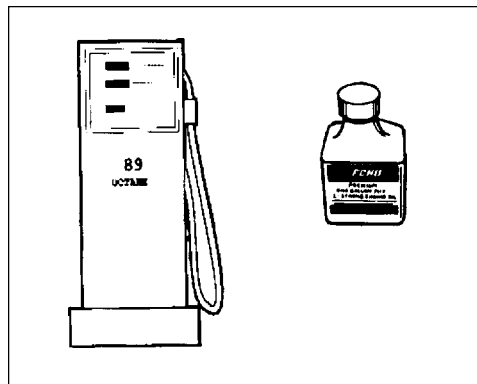

After Refueling;

- Wipe any spilled fuel from the unit.
- Move at least 3 M (10 ft.) from refueling location before starting the engine.

After use;

- DO NOT store a unit with fuel in its tank. Leaks can occur. Return unused fuel to an approved fuel storage container.

Storage -

Fuel storage laws vary by locality. Contact your local government for the laws affecting your area. As a precaution, store fuel in an approved, air tight container. Store in a well ventilated, unoccupied building, away from sparks and flames. Do not store fuel longer than 30 days.

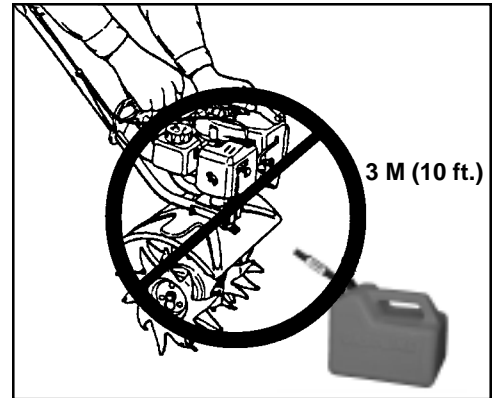

IMPORTANT
Stored fuel ages. Do not mix more fuel than you expect to use in thirty (30) days, ninety (90) days when a fuel stabilizer is added.

IMPORTANT
Stored two-stroke fuel may separate. ALWAYS shake fuel container thoroughly before each use.

S	M	T	W	T	F	S
1	2	3	4	5	6	7
8	9	10	11	12	13	14
15	16	17	18	19	20	21
22	23	24	25	26	27	28
29	30	31				

EQUIPMENT CHECK

Before operation a complete check of the unit must be performed;

- Check unit for loose/missing nuts, bolts and screws. Tighten and/or replace as needed.
- Inspect fuel lines, tank and area around carburetor for fuel leaks. DO NOT operate unit if leaks are found.
- Inspect guard for damage and ensure that it is securely in place. Replace guard if damaged or missing.
- Check that the tines are firmly attached and in safe operating condition

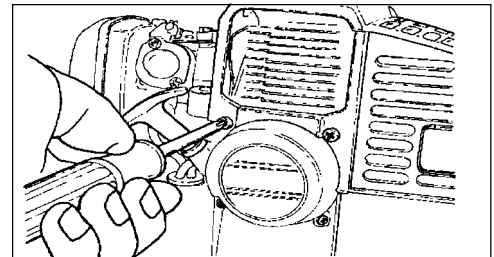

OPERATION

- Provide all operators of this equipment with the Operator's Manual and instructions for safe operation.
- Before starting the unit, equip yourself and any other person working within the 15M (50 ft.) Safety Zone with the required Protective Equipment and clothing.
- During operation, the complete unit, especially the engine and the gear housing may become very hot, too hot to touch. Avoid contact during and immediately after operation.
- Do not operate this product indoors or in inadequately ventilated areas.

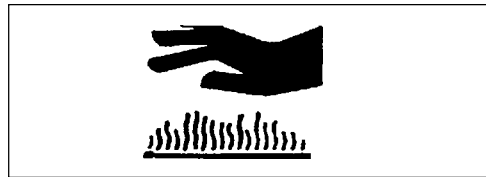

STARTING COLD ENGINE

WARNING DANGER

The tines should not move at idle. If tines move, readjust carburetor according to "Carburetor Adjustment" instructions in this manual or see your ECHO Dealer, otherwise serious personal injury may result.

- 1. STOPSWITCH-START.**
Move Stop Switch (A) to START position.
- 2. CLOSE CHOKE-COLDSTART.**
Move choke (B) to START (closed) position. Throttle must remain at idle for starting.
- 3. PRIMER-PUMPBULB.**
Pump primer bulb (C) 10 times, until fuel is visible in the "Clear" fuel return line.

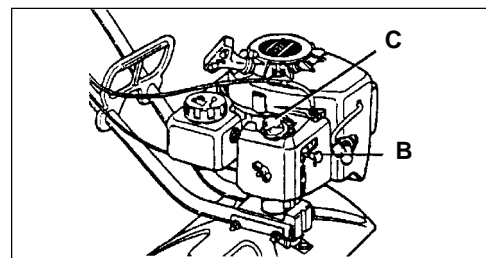
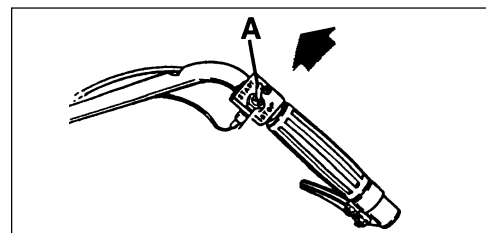

4. **START - PULL ROPE.**
Pull recoil starter rope until engine fires.
5. **OPEN CHOKE - RUN.**
Move choke (B) to RUN (open) position.
6. **RESTART ENGINE - PULL ROPE.**
Pull recoil starter rope until engine fires.

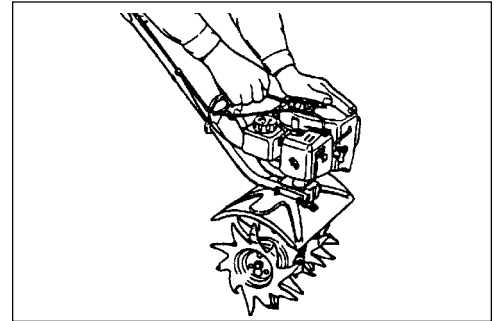

WARNING DANGER

When engine starts, the tines may move even with the throttle trigger in idle (released) position.

STARTING WARM ENGINE

The starting procedure is the same as Cold Start except DO NOT close the choke (B).

NOTE

If engine does not start after 5 pulls, use Cold Start Procedure.

1. **STOP SWITCH - START.**
Place Stop Switch (A) in START position.
2. **PRIMER - PUMP BULB** Pump primer bulb (C) until fuel is visible in the "Clear" fuel return line.
3. **CHOKE - OPEN.**
Be certain choke (B) is open.
4. **START - PULL ROPE.**
Pull recoil starter rope.
5. **START ENGINE.**
Start engine at idle.

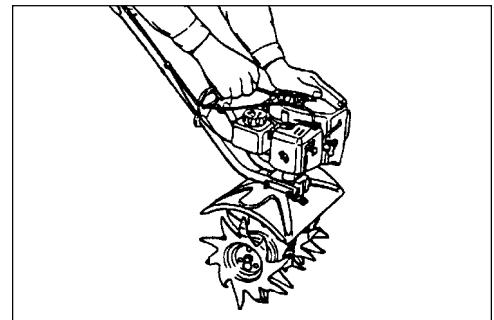
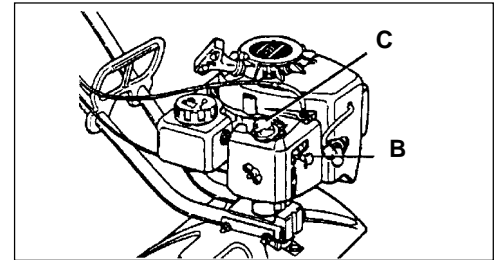

STOPPING ENGINE

1. **RELEASE THROTTLE TRIGGER.**
Release throttle trigger and allow engine to idle for a minute.
2. **STOP SWITCH - STOP.**
Move stop switch to STOP position (A).

WARNING DANGER

If engine does not stop when stop switch is moved to STOP position, close choke - COLD START position - to stall engine. Have your ECHO dealer repair stop switch before using tiller/cultivator again.

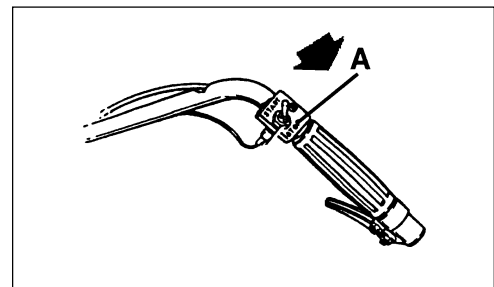

MAINTENANCE

Your ECHO tiller/cultivator is designed to provide many hours of trouble free service. Regular scheduled maintenance will help your tiller/cultivator achieve that goal. If you are unsure or are not equipped with the necessary tools, you may want to take your unit to an ECHO Service Dealer for maintenance. To help you decide whether you want to DO-IT-YOUR-SELF or have the ECHO Dealer do it, each maintenance task has been graded. If the task is not listed, see your ECHO dealer for repairs.

SKILL LEVEL

Level 1= Easy to do. Most required tools come with unit.

Level 2= Moderate difficulty. Some specialized tools may be required.

Level 3= Experience required. Specialized tools are required. ECHO recommends that the unit be returned to your ECHO Dealer for service.

ECHO offers **REPOWER™** Maintenance Kits and Parts to make your maintenance job easier. Just below each task heading are listed the various part numbers required for that task. See your ECHO dealer for these parts.

MAINTENANCE INTERVALS

COMPONENT/ SYSTEM	MAINTENANCE PROCEDURE	REQ'D SKILL LEVEL	DAILY OR BEFORE USE	EVERY REFUEL	3 MONTHS OR 90 HOURS	6 MONTHS OR 270 HOURS	YEARLY 600 HOURS
Recommended Echo Dealer Maintenance Procedures							
Cylinder Exhaust Port	Inspect/Clean/Decarbon	3			I / C		
Do-It-Yourself Maintenance Procedures							
Air Filter	Inspect/Clean/Replace	1	I / C		R*		
Choke	Inspect/Clean	2	I / C				
Fuel Filter	Inspect/Replace	1			I		R *
Fuel System, leaks	Inspect/Replace	1	I *	I*			
Cooling System	Inspect/Clean	2	I / C				
Muffler Spark Arrestor	Inspect/Replace	2			I *		
Gear Housing	Grease	2			I (1)		
Tines	Inspect/Clean	1	I / C				
Recoil Starter Rope	Inspect/Clean	1	I / C *				
Spark Plug	Inspect/Clean	2			I / C	R *	
Screws/Nuts/Bolts	Inspect/Tighten/Replace	1	I / R *				

MAINTENANCE PROCEDURE LETTER CODES: I = INSPECT, R = REPLACE, C = CLEAN

IMPORTANT NOTE - Time intervals shown are maximum. Actual use and your experience will determine the frequency of required maintenance.

MAINTENANCE PROCEDURE NOTES:

(1) Apply ECHO® LUBE™ every 25 hours.

* All recommendations to replace are based on the finding of damage or wear during inspection..

AIR FILTER

Level 1.

Tools required: 25mm-50mm (1 in.-2 in.) medium bristle paint brush.

Parts required: 90008 REPOWER™ AIR & FUEL FILTER KIT.

1. Close choke (Cold Start Position). This prevents dirt from entering the carburetor throat when the air filter is removed. Brush accumulated dirt from the air cleaner area.
2. Remove the air cleaner cover. Clean and inspect the element for damage. If element is fuel soaked and very dirty, replace.
3. If element can be cleaned and reused, be certain it:
 - still seals the cavity in the air cleaner cover.
 - is installed with the original side out.

NOTE

Carburetor adjustment may be needed after air filter cleaning/ replacement. See Carburetor Adjustment Section.

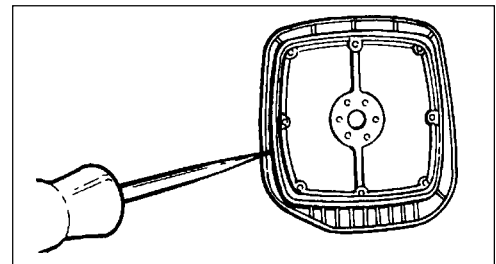
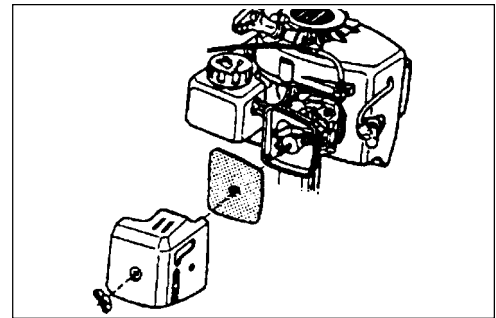
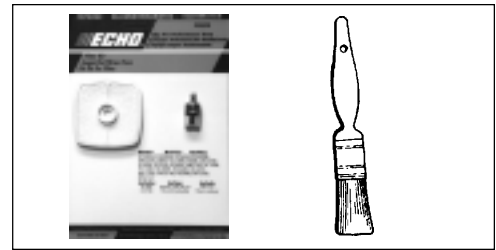

FUEL FILTER

Level 1.

Tools required: Fuel line hook. 203-254mm (8in.-10in.) length of wire with one end bent into a hook. Clean rag, funnel, and an approved fuel container.

Parts required: 90008 REPOWER™ AIR & FUEL FILTER KIT

WARNING DANGER

Fuel is **VERY** flammable. Use extreme care when mixing, storing or handling, or serious personal injury may result.

1. Use a clean rag to remove loose dirt from around fuel cap and empty fuel tank.
2. Use the “fuel line hook” to pull the fuel line and filter (A) from the tank.
3. Remove the filter (A) from the line and install the new filter.

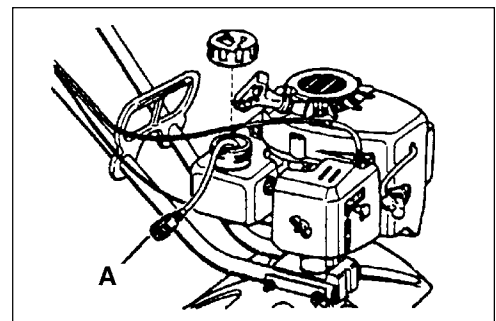

SPARK PLUG

Level 2.

Tools Required: Spark Plug socket wrench and screw driver, Feeler gauge. Preferably a wire gauge.

Parts Required: Spark Plug, NGK - BPM-7Y P/N 99944500071

1. Remove spark plug and check for fouling, worn and rounded center electrode.
2. Clean the plug or replace with a new one. DO NOT sand blast to clean. Remaining sand will damage engine.
3. Adjust spark plug gap by bending outer electrode.
4. Tighten spark plug to 145-155 kg/cm (125-135 in. lb.).

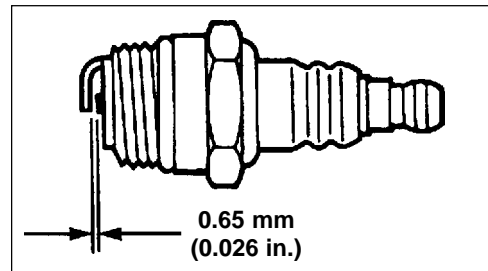
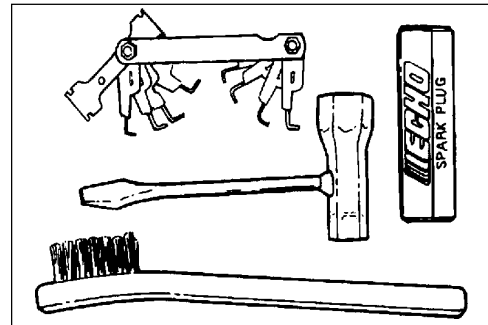

COOLING SYSTEM CLEANING

Level 3.

Tools required: Cross Head Screwdriver, 3mm Hex wrench, Pointed Wood Stick, 25mm-50mm (1 in.-2 in.) medium bristle paint brush.

Parts Required: None.

IMPORTANT

To maintain proper engine operating temperatures, cooling air must pass freely through the cylinder fin area. This flow of air carries combustion heat away from the engine.

Overheating and engine seizure can occur when:

- Air intakes are blocked, preventing cooling air from reaching the cylinder.
- Dust and grass build up on the outside of the cylinder. This build up insulates the engine and prevents the heat from leaving.

Removal of cooling passage blockages or cleaning of cooling fins is considered "Normal Maintenance". Any failure attributed to lack of maintenance is not warranted.

1. Remove spark plug lead and throttle cable end from the carburetor swivel.
2. Remove the four screws that retain the cover. Two at the top of the recoil starter, two on either side of the front. Lift the cover from the engine and lay to the front of the tiller/cultivator.

NOTE

The throttle linkage remains assembled to the cover and the spark plug lead and grommet remain installed.

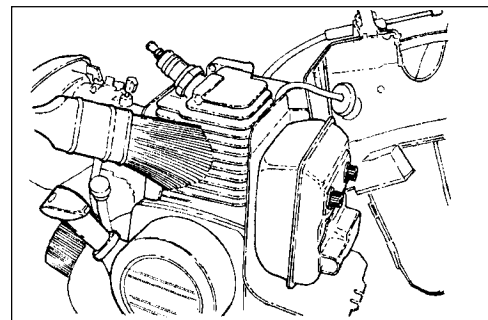
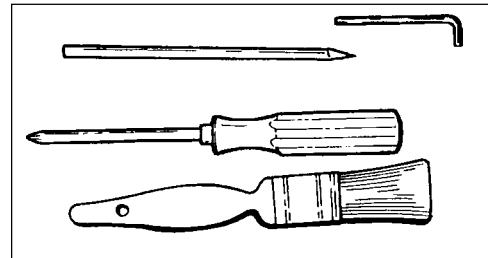

IMPORTANT

DO NOT use a metal scraper to remove dirt from the cylinder fins.

3. Use the wooden stick or brush to remove dirt from the cylinder fins.
4. Remove grass and leaves from the grid between the recoil starter and fuel tank.
5. When installing the cover, be certain the tab of the metal deflector shield is in the slot of the cover.

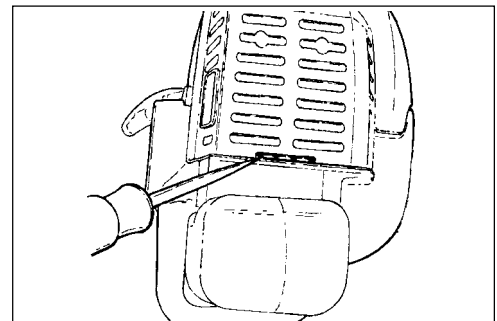
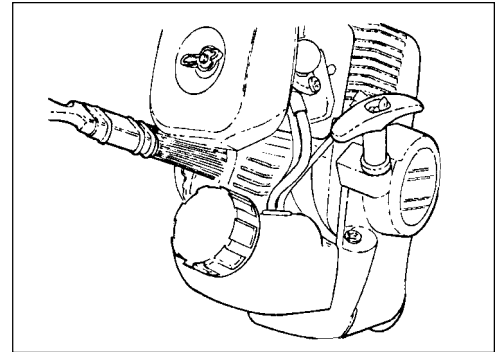

EXHAUST SYSTEM

Spark Arrestor Screen

Level 2.

Tools Required: Cross Head Screwdriver. 3mm Hex wrench. Soft metal brush. Wooden carbon scraper.

Parts Required: P/N 13001642031 Spark Arrestor Screen
P/N 14586642031 Screen Holder

1. Remove screen cover (A), screen holder (B), and gasket (C) from muffler body.
2. Clean carbon deposits from screen (D) and muffler components.
3. Replace screen if it is cracked, plugged or has holes burned through.
4. Install with new gaskets.

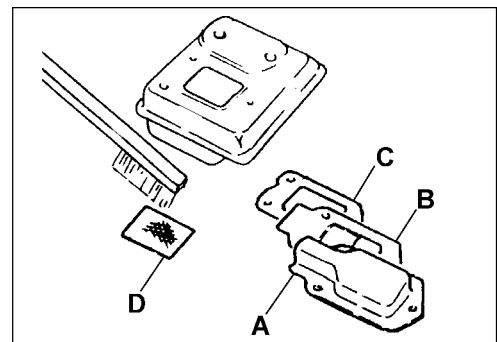
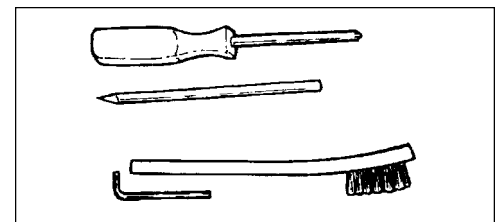

CARBURETOR ADJUSTMENT

Emission Models

Level 2.

Tools required: Screwdriver, Tachometer (ECHO P/N 99051130017).

Parts required: None.

NOTE

Every unit is run at the factory and the carburetor is set in compliance with EPA Phase 1 and California Emission Regulations. In addition, the carburetor is equipped with HI (A) and LO (B) needle adjustment limiters that prevent settings outside acceptable limits.

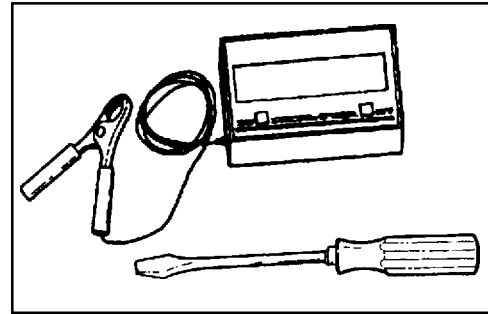

1. Before adjusting the carburetor, clean or replace the air filter and spark arrester screen.
2. Start engine and run for several minutes to reach operating temperature.
3. Stop engine. Turn HI (A) speed needle CCW (counter clockwise) to stop. Turn LO (B) speed needle midway between full CCW and CW (clockwise) stops.
4. Idle Speed Adjustment.
-Start engine and turn idle speed adjustment screw (C), CW until the tines begin to turn, then turn the screw CCW until tines stop turning. Turn screw CCW an additional 1/4 turn.
5. Accelerate to full throttle for 2-3 seconds to clear excess fuel from engine then return to idle. Accelerate to full throttle to check for smooth transition from idle to full throttle. If engine hesitates, turn LO (B) needle CCW an additional 1/8 turn and repeat acceleration. Continue adjusting until smooth acceleration results.
6. Check HI (A) speed RPM at W.O.T. (Wide Open Throttle). HI speed RPM should be set to specifications found on page 10 "Specifications" of this manual.
7. Check idle speed and reset if necessary. If a tachometer is available, idle speed should be set to the specification found on page 10 "Specifications" of this manual.

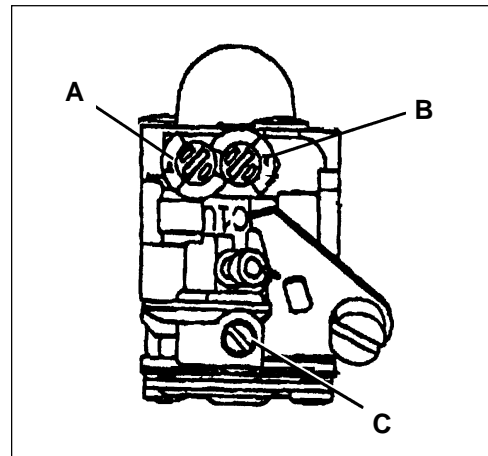

WARNING **DANGER**

When carburetor adjustment is completed, tines should not move at idle, otherwise serious personal injury may result.

CARBURETOR ADJUSTMENT

Non-Emission Models (Without Limiter Caps)

Level 2

Tools Required: Screwdriver, Tachometer (ECHO P/N 90051130017).

NOTE

If carburetor has limiter caps follow "Carburetor Adjustment" procedures for emission models on previous page.

Idle Speed Adjustment

Turn "idle" speed adjustment screw (C) CW (clockwise) until tines begin to turn, then turn screw out CCW (counter clockwise) until tines stop turning. Turn screw out, CCW an additional 1/4 turn.

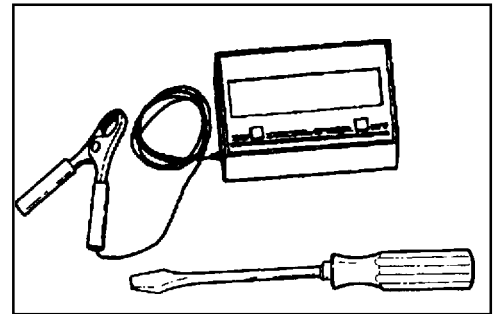

WARNING DANGER

Tines must not turn when unit is idling, otherwise serious personal injury may result.

Basic Setting

1. Stop engine and turn both LO (B) and HI (A) needles in, CW until they stop and are lightly seated.

IMPORTANT

DO NOT over tighten needles. Forcing them to tighten will damage the carburetor.

2. Turn LO (B) needle out, CCW 2-1/2 turns. Turn HI (A) needle out CCW 2-3/4 turns.

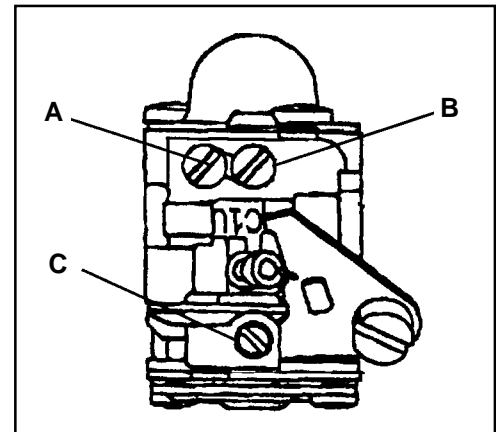

Fine Tuning

(Requires Accurate Tachometer)

1. Start engine and allow to warm to operating temperature (minimum 2 - 3 minutes) varying engine speed from idle to full throttle.
2. Always begin fine tuning with LO (B) needle.
 - a. Lean drop-off - With engine idling, turn LO (B) needle slowly CW (in) to lean drop-off point. RPM will increase, then abruptly drop-off. Note this position. (1)
 - b. Rich drop-off - With engine idling, slowly turn LO (B) needle CCW (out) to rich drop-off point. RPM will increase then gradually slow and drop-off. Note this position. (2)
 - c. Final setting - Set needle at mid point between lean rich drop-off points. (3)
 - d. Turn needle 1/8 turn CCW (out) making mixture slightly richer. (4)
3. HI speed adjustment.
Adjust HI (A) needle with tachometer. Refer to Wide Open Throttle RPM settings listed in "Specifications" on page 10.
4. Check idle speed and reset if necessary. If tachometer is available, idle speed should be set to the specifications found on page 10 "Specifications" of this manual.

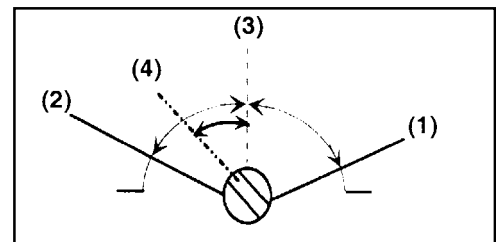

WARNING DANGER

When carburetor adjustment is completed, tines should not move at idle, otherwise serious personal injury may result.

LUBRICATION

Level 1.

Tools Required: Crosshead Screw Driver

Parts Required: Lithium Base Grease.

Gear Housing

1. Remove tines (See Tine Removal - Installation).
2. Clean dirt from area around gear cover (A) and remove four (4) crosshead screw (B). Be careful not to tear sealing gasket (C).
3. Support tiller with exposed gear case (D) upward. Add #0 lithium grease until nearly level with top of gear case (D).

IMPORTANT

Do not over fill. Too much grease will cause pressure and possible seal failure.

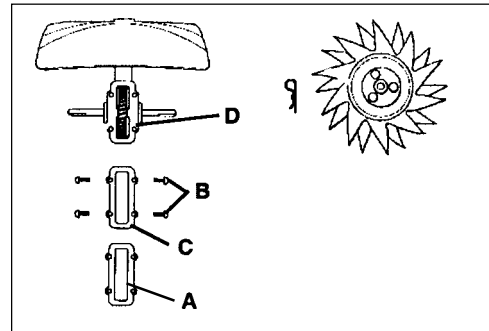
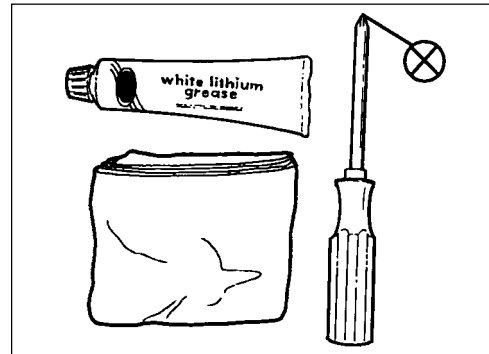

Cleaning Tines (After Each Use)

NOTE

Wear gloves to protect hands from sharp blades.

1. Remove weeds, etc. from tines and wash dirt from unit.

Tine Removal - Installation

WARNING DANGER

Stop engine and disconnect spark plug wire before removing or installing tines. Contact with revolving tines will cause severe injury.

1. Remove retaining pin (E) and slide tine from shaft.
2. Clean accumulated dirt and debris from gear housing and tine shaft.
3. Slide tine on shaft, D-hole (hole with flat on one side) goes to the outside, install retaining pin.

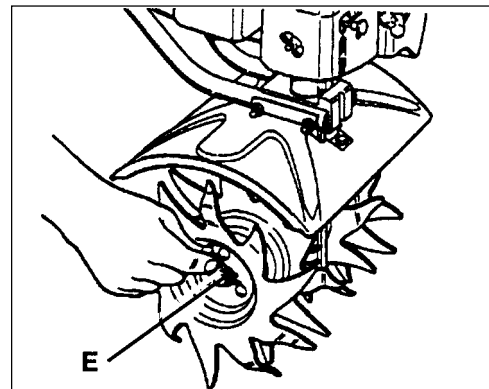

TROUBLESHOOTING

Problem			Cause	Remedy
Engine -- starts hard				
Engine -- does not start			Cause	Remedy
Engine Cranks ↓	Fuel at carburetor ↓	No fuel at carburetor	Fuel strainer clogged Fuel line clogged Carburetor	Clean Clean See your ECHO dealer
	Fuel at cylinder ↓	No fuel at cylinder	Carburetor	See your ECHO dealer
		Muffler wet with fuel	Fuel Mixture is too rich	Open choke Clean/replace air filter Adjust carburetor See your ECHO dealer
	Spark at end of plug wire ↓	No spark at end of plug wire	Stop switch off Electrical problem Interlock switch	Turn switch on See your ECHO dealer See your ECHO dealer
	Spark at plug ↓	No spark at plug	Spark gap incorrect Covered with carbon Fouled with fuel Spark plug defective	Adjust 0.65mm (0.026in.) Clean or replace Clean or replace Replace plug
Engine does not crank			Internal engine problem	See your ECHO dealer
Engine runs ↓	↓		Air filter dirty Fuel filter dirty Fuel vent plugged Spark plug Carburetor Cooling system plugged Exhaust port/spark arrestor screen plugged	Clean or replace Replace Replace Clean and adjust/replace Adjust Clean Clean

WARNING  **DANGER**

Fuel vapors are **extremely** flammable and may cause fire and/or explosion. **Never** test for ignition spark by grounding spark plug against cylinder, otherwise serious personal injury may result.

STORAGE

Long Term Storage (over 30 days)

Do not store your unit for a prolonged period of time (30 days or longer) without performing protective storage maintenance which includes the following:

1. Store unit in a dry, dust free place, out of the reach of children.

WARNING DANGER

Do not store in enclosure where fuel fumes may accumulate or reach an open flame or spark. Failure to do so could result in serious personal injury or property damage.

2. Place the stop switch in the "OFF" (A) position.
3. Remove accumulation of grease, oil, dirt and debris from exterior of unit.
4. Perform all periodic lubrication and services that are required.
5. Tighten all the screws and nuts.
6. **Drain** the fuel tank **completely** and pull the recoil starter handle several times to remove fuel from the carburetor.
7. Remove the spark plug and pour 7cc (1/4 oz., 1/2 tablespoon) of fresh, clean, two-stroke engine oil into the cylinder through the spark plug hole.
 - A. Place a clean cloth over the spark plug hole.
 - B. Pull the recoil starter handle 2-3 times to distribute the oil inside the engine.
 - C. Observe the piston location through the spark plug hole. Pull the recoil handle slowly until the piston reaches the top of its travel and leave it there.
8. Install the spark plug (do not connect spark plug cable).

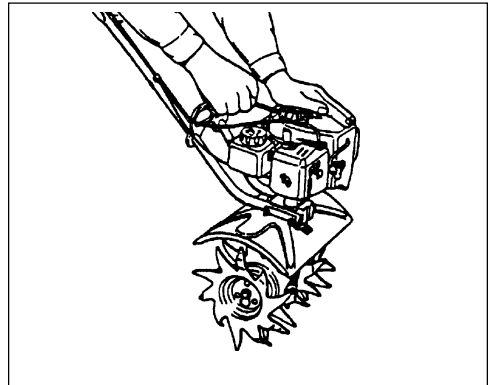
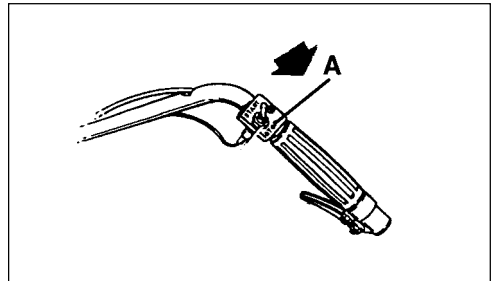

NOTES

NOTES

NOTES

SERVICING INFORMATION

PARTS

Genuine ECHO Parts and ECHO Re Power™ Parts and Assemblies for your ECHO products are available only from an Authorized ECHO Dealer. When you do need to buy parts **always** have the Model Number, Type number and Serial Number of the unit with you. You can find all three numbers on the engine housing. For future reference, write them in the space provided below.

Model No. _____ Type No. _____ SN. _____

SERVICE

Service of this product during the warranty period must be performed by an Authorized ECHO Service Dealer. For the name and address of the Authorized ECHO Service Dealer nearest you, ask your retailer or call: 1-800-432-ECHO (3246). When presenting your unit for Warranty service/repairs, proof of purchase is required.

ECHO CONSUMER PRODUCT SUPPORT

If you require assistance or have questions concerning the application, operation or maintenance of this product you may call the ECHO Consumer Product Support Department at 1-800-673-1558 from 8:00 am to 5:00 pm (Central Standard Time) Monday through Friday. Before calling, please know the model and serial number of your unit to help your Consumer Product Support Representative.

WARRANTY CARD

This card is our means of registering all original owners of ECHO equipment. The card plus proof of purchase provides you the assurance that authorized warranty work will be done. It also provides a direct link between you and ECHO if we find it necessary to contact you.

ADDITIONAL OR REPLACEMENT MANUALS

Operator's and Parts Manuals are available for purchase from your ECHO dealer or directly from ECHO. [See ordering instructions at the end of this manual.]

ORDERING INSTRUCTIONS

To obtain a Parts Catalog or Operator's Manual send a check or money order for \$2.00 per Parts Catalog or \$1.50 per Operator's Manual made payable to ECHO, INCORPORATED. State on a sheet of paper model number and serial number of the ECHO unit you have, part number of the manual (if known), your name and address and mail to address above.

Available Parts Lists

TC-2100 TYPE 1 (S/N 011441 & UP) TYPE 1E (S/N 001001 & UP)

PART NUMBER 99922202874

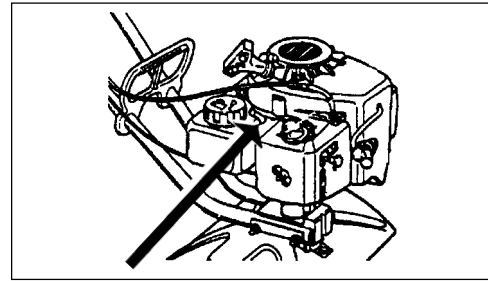

DEALER?
Call
1-800-432-ECHO

CONSUMER PRODUCT
SUPPORT
1-800-673-1558
8 - 5 Mon - Fri C.S.T.

ECHO LIMITED WARRANTY REGISTRATION CARD / CARTE D'ENREGISTREMENT DE GARANTIE LIMITEE			
Please Print / Ecrivez en caractères d'imprimerie			
Purchaser's Name / Nom de l'acheteur			
Address / Adresse			
City / Ville	State / État / Province		
Zip Code / Code Postal			
Dealer Number / No. de concessionnaire			
Date of Purchase / Date d'achat			
Store Name Where Purchased / Nom de l'établissement d'achat			
Model Number / Numéro de modèle	Type No. / No. de type		
Serial Number / Numéro de série			
Dealer Signature (if Applicable) / Signature du concessionnaire (si applicable)			
<table border="0"> <tr> <td style="vertical-align: top;"> <p>A. Primary use of tool / Usage principal de l'outil</p> <p>1. () Professional/Landscaper / Professionnel/Paysagiste</p> <p>2. () Homeowner/Particularier</p> </td> <td style="vertical-align: top;"> <p>B. Safety / Operational information received with product / Informations de sécurité / Fonctionnement fournies avec le produit</p> <p>1. () Operator's Manual / Manuel d'opération</p> <p>2. () Safety Notices / Notices de sécurité</p> <p>3. () Safety Manual / Manuel de sécurité</p> </td> </tr> </table>		<p>A. Primary use of tool / Usage principal de l'outil</p> <p>1. () Professional/Landscaper / Professionnel/Paysagiste</p> <p>2. () Homeowner/Particularier</p>	<p>B. Safety / Operational information received with product / Informations de sécurité / Fonctionnement fournies avec le produit</p> <p>1. () Operator's Manual / Manuel d'opération</p> <p>2. () Safety Notices / Notices de sécurité</p> <p>3. () Safety Manual / Manuel de sécurité</p>
<p>A. Primary use of tool / Usage principal de l'outil</p> <p>1. () Professional/Landscaper / Professionnel/Paysagiste</p> <p>2. () Homeowner/Particularier</p>	<p>B. Safety / Operational information received with product / Informations de sécurité / Fonctionnement fournies avec le produit</p> <p>1. () Operator's Manual / Manuel d'opération</p> <p>2. () Safety Notices / Notices de sécurité</p> <p>3. () Safety Manual / Manuel de sécurité</p>		
<p>TO PURCHASE A COPY OF THE ECHO SAFETY VIDEO OR VIDEO CONTACT / POUR ACQUERIR UN EXEMPLAIRE DE LA VIDEO CONTACT DE SECURITE ECHO, CONTACTER:</p> <p style="text-align: right;">ECHO, INCORPORATED ATTN: VIDEO OFFICE 400 OAKWOOD RD. LAKE ZURICH, IL 60047 U.S.A. OWNER COPY/COPIE DU PROPRIETAIRE 8881124000</p>			

ECHO Incorporated
400 Oakwood Road
Lake Zurich, IL 60047
Technical Publications Orders

ECHO
ECHO, INCORPORATED
400 OAKWOOD ROAD
LAKE ZURICH, IL 60047