



# Shaft Hedge Clipper

## *Operator's Manual*

**MODEL**

**SHC-2100**

**Serial Number 0517101 & Up**

**WARNING**  **DANGER**



The muffler or catalytic muffler and surrounding cover may become extremely hot.

Always keep clear of exhaust and muffler area, otherwise serious personal injury may occur.



**WARNING**



The engine exhaust from this product contains chemicals known to the State of California to cause cancer, birth defects or other reproductive harm.



**WARNING**  **DANGER**

Read rules for safe operation and instructions carefully. ECHO provides an Operator's Manual and a Safety Manual. Both must be read and understood for proper and safe operation. Failure to do so could result in serious injury.

## INTRODUCTION

Welcome to the ECHO family. This ECHO product was designed and manufactured to provide long life and on-the-job-dependability. Read and understand this manual and the SAFETY MANUAL you found in the same package. You will find both easy to use and full of helpful operating tips and SAFETY messages.

### THE OPERATOR'S MANUAL

Read and understand this manual before operation. Keep it in a safe place for future reference. It contains specifications and information for operation, starting, stopping, maintenance, storage and assembly specific to this product.

### THE SAFETY MANUAL

Read and understand this manual before operation. Keep it in a safe place for future reference. It explains possible hazards involved with the use of Hedge Clippers and what measures you should take to make their use safer.

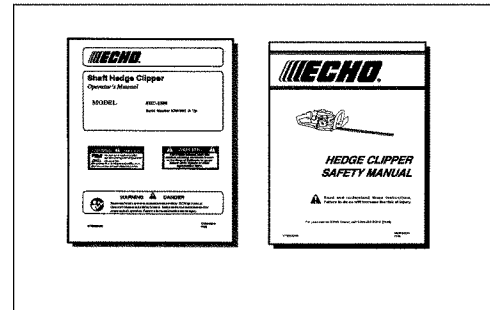

## TABLE OF CONTENTS

Introduction .....	2	- Stopping Engine .....	14
- The Operator's Manual .....	2	Maintenance .....	14
- The Safety manual .....	2	- Skill Levels .....	14
Manual Safety Symbols and Important Information ..	3	- Maintenance Intervals .....	15
Safety .....	3	- Air Filter .....	16
- Decals .....	3	- Fuel Filter .....	16
- International Symbols .....	4	- Spark Plug .....	17
Safety Instructions .....	4	- Cooling System Cleaning .....	17
- Personal Conditions and Safety Equipment .....	4	- Exhaust System .....	18
- Extended Operation/Extreme Conditions .....	5	- Carburetor Adjustment Emission .....	19
- Equipment .....	5	- Lubrication .....	20
- Safe Operation .....	6	- Sharpening Blades .....	21
Emissions Control .....	6	Troubleshooting .....	22
Description .....	7	Storage .....	23
- Contents .....	7*	Servicing Information .....	24
Specifications .....	9	- Parts .....	24
Assembly .....	10	- Service .....	24
- Gear Housing Assembly / Drive Shaft .....	10	- ECHO Consumer Product Support .....	24
Pre-Operation .....	11	- Warranty Card .....	24
- Fuel .....	11	- Additional or Replacement Manuals .....	24
Operation .....	12	*Page 7 Supplement .....	25
- Starting Cold Engine .....	12*	*Page 12 Supplement .....	25
- Starting Warm Engine .....	13		

Specifications, descriptions and illustrative material in this literature are as accurate as known at the time of publication, but are subject to change without notice. Illustrations may include optional equipment and accessories, and may not include all standard equipment.

## MANUAL SAFETY SYMBOLS AND IMPORTANT INFORMATION

Throughout this manual and on the product itself, you will find safety alerts and helpful, information messages preceded by symbols or key words. The following is an explanation of those symbols and key words and what they mean to you.



This symbol accompanied by the words **WARNING** and **DANGER** calls attention to an act or condition that can lead to serious personal injury to operator and bystanders.



The circle with the slash symbol means whatever is shown within the circle is prohibited.



**IMPORTANT** The enclosed message provides information necessary for the protection of the unit.

**NOTE** This enclosed message provides tips for use, care and maintenance of the unit.

## SAFETY

### DECALS

Locate this safety decal on your unit. The complete unit illustration found in the "DESCRIPTION" section, will help you locate them. Make sure the decals are legible and that you understand and follow the instructions on them. If a decal cannot be read, a new one can be ordered from your ECHO dealer. See PARTS ORDERING instructions for specific information.

### HANDGUARD



### WARNING DANGER



This unit is not designed to insulate against hazards associated with the contact of wires carrying electrical current. To avoid possible injury/death due to electrical shock or other hazards. DO NOT operate unit if any wires (power, telephone, cable, etc.) are closer than 15 feet (4.5 meters) minimum distance, to any part of the unit or operator. • This unit can be dangerous if used improperly. • Falling objects and/or blade contact can cause serious injury to operator, helpers and bystanders. • Keep helpers and bystanders at least 50 feet (15m) clear of operating area. • To reduce injury risk, READ AND UNDERSTAND the Operator's Manual. Replacement copies are available through any ECHO Dealer.



- Wear Protective Clothing (head, hearing and eye protection meeting ANSI standards) specified in the Operator's Manual.

STOP engine before making repairs or blade adjustments. • Keep hand away from blade.



## INTERNATIONAL SYMBOLS

Symbol form/shape	Symbol description/application	Symbol form/shape	Symbol description/application
	Read and understand Operator's Manual.		Fuel and oil mixture
	Wear eyes, ears and head protection		Finger Severing
	Hot Surface		Wear hand protection. Use two handed.
	Safety/Alert		DO NOT smoke near fuel.
	Avoid all power lines. This unit is not insulated against electrical current.		DO NOT allow flames or sparks near fuel.
	Do not operate closer than 15 M (50 ft.) from electrical hazards.		

Symbol form/shape	Symbol description/application	Symbol form/shape	Symbol description/application
	Keep bystanders at least 15 meters (50 feet) away.		Plan retreat path from falling objects.
	Emergency stop		Wear slip resistant foot wear.
	Engine choke control.		Ignition ON/OFF
	Primer bulb		Carburetor adjustment - High speed mixture
	Carburetor adjustment - Low speed mixture		Carburetor adjustment - Idle speed

## SAFETY INSTRUCTIONS

### PERSONAL CONDITION AND SAFETY EQUIPMENT

#### WARNING DANGER

Hedge Clipper users risk injury to themselves and others if the hedge clipper is used improperly and or safety precautions are not followed. Proper clothing and safety gear must be worn when operating a hedge clipper.

#### *Eye Protection*

Eye protection that meet ANSI Z87.1 or CE requirements must be worn whenever you operate the Hedge Clipper.

#### *Hand Protection*

Wear no-slip, heavy duty work gloves to improve your grip on the handles. Gloves also reduce the transmission of machine vibration to your hands.

#### *Hearing Protection*

Wear hearing protection. ECHO recommends wearing hearing protection whenever unit is used.

#### *Proper Clothing*

Wear snug fitting, durable clothing;

- Pants should have long legs, shirts with long sleeves.
- DONOT WEAR SHORTS,
- DONOT WEAR TIES, SCARFS, JEWELRY.

Wear protective hair covering to contain long hair.

Wear sturdy work shoes with nonskid soles;

- DONOT WEAR OPEN TOED SHOES,
- DONOT OPERATE UNIT BAREFOOTED.

Wear no-slip, heavy duty work gloves.

**EXTENDED OPERATION/EXTREME CONDITIONS**

***Vibration and Cold***

It is believed that a condition called Raynaud's Phenomenon, which affects the fingers of certain individuals, may be brought about by exposure to vibration and cold. Exposure to vibration and cold may cause tingling and burning sensations, followed by loss of color and numbness in the fingers. The following precautions are strongly recommended, because the minimum exposure which might trigger the ailment is unknown.

- Keep your body warm, especially the head, neck, feet, ankles, hands, and wrists.
- Maintain good blood circulation by performing vigorous arm exercises during frequent work breaks, and also by not smoking.
- Limit the hours of operation. Try to fill each day with jobs where operating the trimmer or other hand-held power equipment is not required.
- If you experience discomfort, redness and swelling of the fingers followed by whitening and loss of feeling, consult your physician before further exposing yourself to cold and vibration.

***Repetitive Stress Injuries***

It is believed that overusing the muscles and tendons of the fingers, hands, arms, and shoulders may cause soreness, swelling, numbness, weakness, and extreme pain in those areas. Certain repetitive hand activities may put you at a high risk for developing a Repetitive Stress Injury (RSI). An extreme RSI condition is Carpal Tunnel Syndrome (CTS), which could occur when your wrist swells and squeezes a vital nerve that runs through the area. Some believe that prolonged exposure to vibration may contribute to CTS. CTS can cause severe pain for months or even years.

To reduce the risk of RSI/CTS, do the following:

- Avoid using your wrist in a bent, extended, or twisted position. Instead try to maintain a straight wrist position. Also, when grasping, use your whole hand, not just the thumb and index finger.
- Take periodic breaks to minimize repetition and rest your hands.
- Reduce the speed and force with which you do the repetitive movement.
- Do exercises to strengthen the hand and arm muscles.
- Immediately stop using all power equipment and consult a doctor if you feel tingling, numbness, or pain in the fingers, hands, wrists, or arms. The sooner RSI/CTS is diagnosed, the more likely permanent nerve and muscle damage can be prevented.

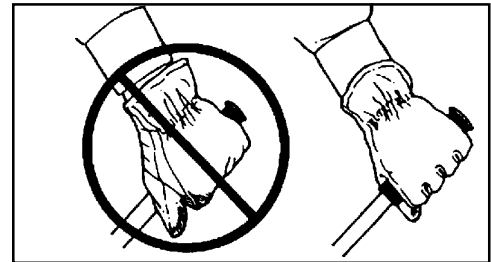

**EQUIPMENT**

**WARNING  DANGER**

Use only ECHO approved attachments. Serious injury may result from the use of a non-approved attachment combination. ECHO, INC. will not be responsible for the failure of cutting devices, attachments, or accessories which have not been tested and approved by ECHO. Read and comply with all safety instructions listed in this manual and safety manual.

- Check unit for loose/missing nuts, bolts, and screws. Tighten and/or replace as needed.
- Inspect fuel lines, tank and area around carburetor for fuel leaks. DO NOT operate unit if leaks are found.
- Never adjust blades when the engine is operating.
- Inspect hand guard for damage. Replace if damaged or missing.
- Check that the blade assembly is firmly attached and in safe operating condition. Dull, loose or damaged blades should not be used.
- ECHO, INC. will not be responsible for the failure of cutting devices or accessories which have not been tested and approved by ECHO for use with this unit.
- Keep exhaust area clear of flammable debris. Avoid contact during and immediately after operation.

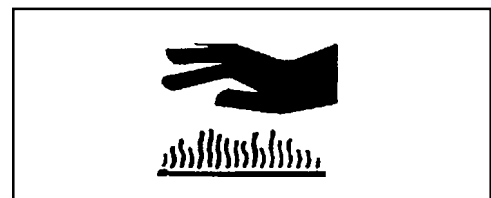

## SAFE OPERATION

### WARNING DANGER

Do not operate this product indoors or in inadequately ventilated areas. Engine exhaust contains poisonous emissions and can cause serious injury or death.

Provide all users of this equipment with the Operator's Manual and instructions for Safe Operation.

#### Keep a Solid Stance

- Maintain footing and balance at all times. Do not stand on slippery, uneven or unstable surfaces. Do not work in odd positions or on ladders. Do not over reach.

#### Keep a Firm Grip

- Hold the front and rear handles with both hands, with thumbs and fingers tightly encircling the handles.

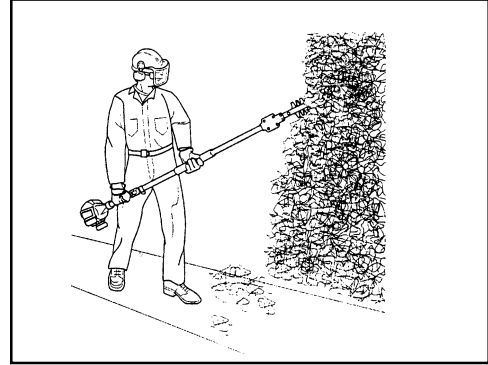

## EMISSION CONTROL

### *EPA Phase II*

The emission control system for this engine is EM (Engine Modification).

**Emission Control Label** (located on Engine) (EXAMPLE ONLY, information on label varies by FAMILY).

#### IMPORTANT ENGINE INFORMATION

ENGINE FAMILY: 2EHXS.0214RA DISPLACEMENT: 21.2 cc  
EMISSION COMPLIANCE PERIOD: 300 Hours  
THIS ENGINE MEETS U.S. EPA PHASE 2 EMISSION REGULATIONS FOR SMALL NONROAD ENGINE.  
REFER TO OWNER'S MANUAL FOR MAINTENANCE SPECIFICATIONS AND ADJUSTMENTS.



**KOATZ CORP.** 

### PRODUCT EMISSION DURABILITY

The 300 hour emission durability compliance period is the time span selected by the manufacturer certifying the engine emissions output meets applicable EPA emissions regulations, provided that approved maintenance procedures are followed as listed in the Maintenance Section of this manual.

## DESCRIPTION

The ECHO product you have purchased has been factory pre-assembled for your convenience. Due to packaging restrictions, some assembly of SHC-2100 is required.

After opening the carton, check for damage. Immediately notify your retailer or ECHO Dealer of damaged or missing parts. Use the contents list to check for missing parts.

## CONTENTS LIST

- \_\_\_\_\_ 1 - Shaft Hedge Clipper Assembly
- \_\_\_\_\_ 1 - Operator's Manual
- \_\_\_\_\_ 1 - Hedge Clipper Safety Manual
- \_\_\_\_\_ 1 - Warranty Statement
- \_\_\_\_\_ 1 - Warranty Registration Card
- \_\_\_\_\_ 1 - 2-Stroke Oil Sample, 2.6 oz.
- \_\_\_\_\_ 1 - T-Wrench
- \_\_\_\_\_ 1 - 4mm Hex Wrench

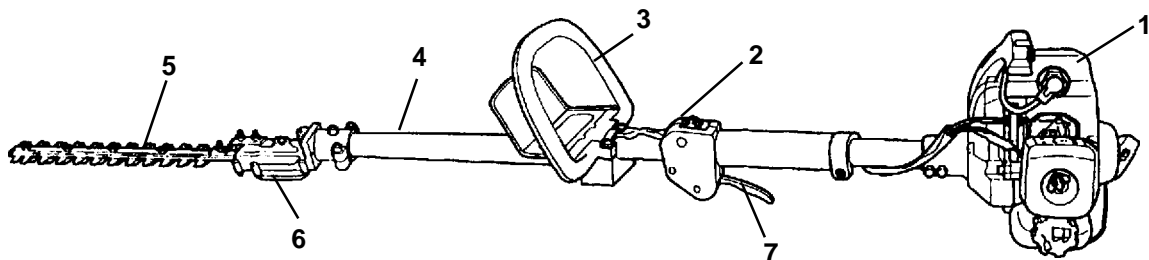
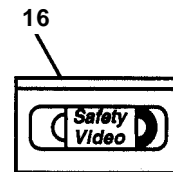
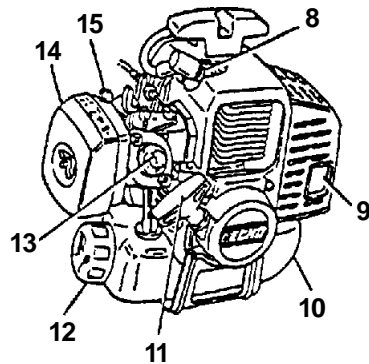
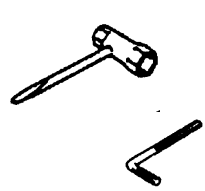
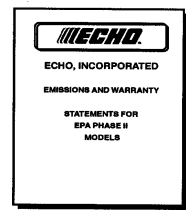
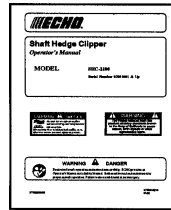

1. **POWER HEAD** - Factory Assembled. Includes the Engine, Clutch, Fuel System, Ignition System and Recoil Starter.
2. **STOP SWITCH** - mounted on top of the Throttle Trigger Housing. Move switch FORWARD to RUN, BACK to STOP.
3. **FRONT HAND (LEFT) HANDLE** - Adjustable for proper cutting attitude and operator comfort.
4. **BLADES** - Double reciprocating blades mounted to a blade support bar. Double sided blades, are capable of cutting on either side of the blade.
5. **GEARHOUSING ASSEMBLY** - Gear housing assembly fixed straight extension.
6. **DRIVE SHAFT ASSEMBLY** - Contains the Flexible Drive Cable.
7. **THROTTLE TRIGGER** - Spring loaded to return to idle when released. During acceleration, depress gradually for best operating technique.
8. **SPARK PLUG** - Provides spark to ignite fuel mixture.
9. **MUFFLER/SPARK ARRESTOR** - The muffler controls the exhaust noise while the spark arrestor prevents hot, glowing particles of carbon from leaving the muffler where they could possibly start a fire.
10. **FUEL TANK** - Contains fuel and fuel filter.
11. **RECOIL STARTER HANDLE** - Pull handle slowly until starter engages, then quickly and firmly. **DO NOT** pull rope all the way out or allow the handle to snap back, damage to the recoil starter will occur.
12. **FUEL TANK CAP** - Covers and seals fuel tank opening.
13. **PURGE BULB** - Before starting and after filling the fuel tank, pump purge bulb 3-4 times or until a steady stream of fresh fuel is visible through the "clear" fuel return line.
14. **AIR CLEANER** - Contains replaceable filter element.
15. **CHOKE CONTROL** - The choke control lever is located on the top of the air filter case. Move the lever to "COLD START" to close the choke and back to "RUN" to open the choke.
16. **HEDGE CLIPPERS SAFETY VIDEO** - P/N 99922202800 (Not included with unit and English version only) is available for your review and purchase at a cost of \$5.00 from ECHO, INC. or any authorized ECHO dealer. The video overviews safety precautions and proper operating techniques provided in detail in the Safety Manual, and is supplemental to the Safety Manual. Read and understand the Safety Manual for complete information on safe operation.

**SPECIFICATIONS**

<b>MODEL</b>	<b>SHC-2100</b>
Length	1816 mm (71.5 in.)
Width	216 mm (8.5 in.)
Height	235 mm (9.3 in.)
Weight (dry) *	5.8 kg (12.9 lb.)
Engine Type	Air cooled, two-stroke, single cylinder gasoline engine
Bore	32.2 mm (1.27 in.)
Stroke	26.0 mm (1.04 in.)
Displacement	21.2 cc (1.29 cu. in.)
Exhaust	Spark Arrestor Muffler
Carburetor	Diaphragm w/primer
Ignition System	Flywheel Magneto, CDI (capacitor discharge ignition) with ESG
Spark Plug	NGK BPM-7Y (Gap 0.65 mm (0.026 in.))
Fuel	Mixed (Gasoline and Two-stroke Oil)
Fuel/Oil Ratio	50:1 ECHO High Performance, two-stroke air cooled engine oil
Gasoline	89 Octane unleaded. DO NOT use fuel containing methyl alcohol, more than 10% ethyl alcohol or 15% MTBE.
Oil	50:1 ECHO High Performance, two-stroke air cooled engine oil
Fuel Tank Capacity	0.4 lit. (14.0 US fl. oz.)
Recoil Starter System	Automatic Recoil Starter
Clutch	Centrifugal Type
Gear Case Ratio	6.36:1 Reduction
Gear Case Lubrication	All purpose lithium based grease every 50 hours of use
Cutter	Double Reciprocating Blade - Double Edge
Length	524 mm (20.5 in.)
Pitch	35 mm (1.4 in.)
Idle Speed	2800 - 3200 RPM
Wide Open Throttle Speed	8000 - 10000 RPM

## ASSEMBLY

### GEAR HOUSING ASSEMBLY/DRIVE SHAFT

*Tools Required:* 8mm x 10mm Open End Wrench, 4 mm Hex Wrench

*Parts Required:* Power Head/Drive Shaft Assembly and Gear Housing Assembly.

#### NOTE

Hedge Clipper Blades are very sharp. Wear gloves to protect hands.

1. Slide the Gear Housing Assembly on the Drive Shaft. Be certain the Flex Drive Shaft engages the hole in Driver Gear.
2. Align the locating screw (A) with the locating hole (B) in the Drive Shaft Housing, tighten screw (A) and clamping screws (C).

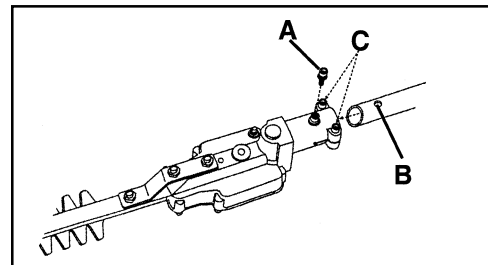

## PRE-OPERATION

### FUEL

#### *Fuel Requirements*

**Gasoline** - Use 89 Octane [ $\frac{R+M}{2}$ ] (mid grade or higher) gasoline known to be good quality. Gasoline may contain up to 15% MTBE (methyl tertiary-butyl ether). Gasohol containing methyl (wood) alcohol is **NOT** approved.

**Two Stroke Oil** - A two-stroke engine oil meeting ISO-L-EGD (ISO/CD 13738) and J.A.S.O. FC Standards, must be used. Echo brand Premium 50:1 oil meets these standards. Engine problems due to inadequate lubrication caused by failure to use an ISO-L-EGD and J.A.S.O. FC certified oil, such as Echo Premium 50:1 Two-stroke Oil, will void the two-stroke engine warranty. (Emission related parts only are covered for two years, regardless of two-stroke oil used, per the statement listed in the EPA Phase II Emission Defect Warranty Explanation.)

#### **IMPORTANT**

Echo Premium 2-Stroke Oil may be mixed at 50:1 ratio for application in all Echo engines sold in the past regardless of ratio specified in those manuals.

#### Mixing Instructions

1. Fill an approved fuel container with half of the required amount of gasoline.
2. Add 2-stroke oil to gasoline.
3. Close container and shake to mix oil with gasoline.
4. Add remaining gasoline and remix.
5. Install fuel container cap and wipe any spilled fuel from container and surrounding area.

#### *Handling Fuel*

### **WARNING DANGER**

Fuel is **VERY** flammable. Use extreme care when mixing, storing or handling or serious personal injury may result.

- Use an approved fuel container.
- **DO NOT** smoke near fuel.
- **DO NOT** allow flames or sparks near fuel.
- Fuel tanks/cans may be under pressure. Always loosen fuel caps slowly allowing pressure to equalize.
- **NEVER** refuel a unit when the engine is **HOT!**
- **NEVER** refuel a unit with the engine running.
- **DO NOT** fill fuel tanks indoors. **ALWAYS** fill fuel tanks outdoors over bare ground.
- Securely tighten fuel cap after refueling.
- Inspect for fuel leakage. If fuel leakage is found, do not start or operate unit until leakage is repaired.

#### **IMPORTANT**

Spilled fuel is a leading cause of hydrocarbon emissions. Some states may require the use of automatic fuel shut-off containers to reduce fuel spillage. Contact your ECHO dealer for ordering information.

#### *After Refueling*

- Wipe any spilled fuel from the unit.
- Move at least 3 m (10 ft.) from refueling location before starting the engine.

#### *After use*

- **DO NOT** store a unit with fuel in its tank. Leaks can occur. Return unused fuel to an approved fuel storage container.

**Storage** - Fuel storage laws vary by locality. Contact your local government for the laws affecting your area. As a precaution, store fuel in an approved, air tight container. Store in a well ventilated, unoccupied building, away from sparks and flames. Do not store fuel longer than 30 days.

#### **IMPORTANT**

Stored fuel ages. Do not mix more fuel than you expect to use in thirty (30) days, ninety (90) days when a fuel stabilizer is added.

#### **IMPORTANT**

Stored two-stroke fuel may separate. **ALWAYS** shake fuel container thoroughly before each use.

## OPERATION

### STARTING COLD ENGINE

#### WARNING DANGER

Blades should not move at idle. If blades move, readjust carburetor according to Carburetor Adjustment instructions in the manual or see your ECHO dealer, otherwise serious personal injury may result.

#### NOTE

Refer to the Hedge Clipper Safety Manual for proper and safe hedge clipping operation.

1. *Stop Switch* - Start/Run.  
Move Stop Switch button away from the STOP position.
2. *Close Choke* - Cold Start.  
Move choke (B) to "Cold Start" position.
3. *Primer* - Pump Bulb.  
Pump primer bulb (C) until fuel is visible and flows freely in the clear fuel tank return line. Pump bulb an additional 4 or 5 times.

#### WARNING DANGER

Inspect starting area for hazards such as rocks, glass, debris etc. which could be contacted by the cutting blades when starting. Keep helpers and bystanders at least 15 M (50 ft.) from starting area, otherwise serious personal injury may result.

4. *Starting*  
Lay the unit on a flat, clear area. Firmly grasp throttle grip with left hand and fully depress throttle trigger to wide open position. Rapidly pull starter handle/rope (D) until engine fires (or maximum five (5) pulls.
5. After engine fires or five (5) pulls, move choke lever back to "RUN" position. Hold throttle trigger fully depressed and pull starter handle/rope until engine starts and runs. Release throttle trigger and allow unit to warm up at idle for several minutes.

#### NOTE

If engine does not start with choke in "RUN" position after 5 pulls, repeat instructions.

6. After engine warm up, gradually depress throttle trigger to increase engine RPM to operating speed.

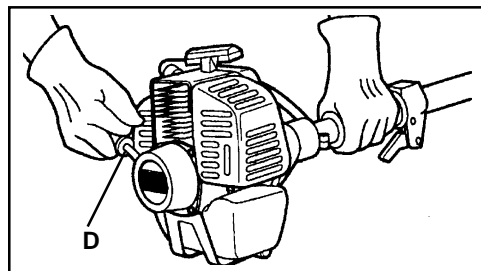
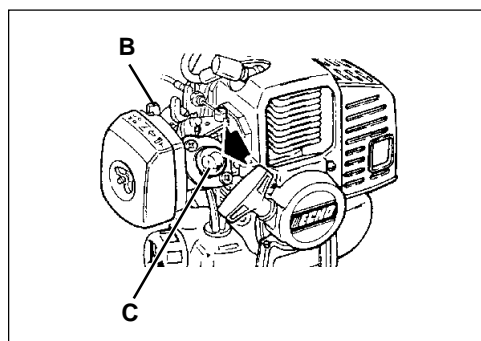
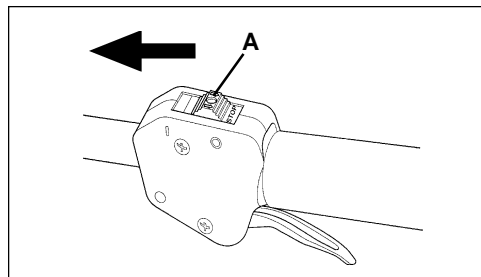

## STARTING WARM ENGINE

The starting procedure is the same as Cold Start except DO NOT close the choke.

### NOTE

If engine does not start after 5 pulls, use Cold Start Procedure.

### WARNING DANGER

Blades should not move at idle. If blades move, readjust carburetor according to Carburetor Adjustment instructions in the manual or see your ECHO dealer, otherwise serious personal injury may result.

1. *Stop Switch -Start/Run.*  
Move Stop Switch button (A) away from the STOP position.
2. *Primer - Pump Bulb.*  
Pump primer bulb (C) until fuel is visible and flows freely in the clear fuel tank return line. Pump bulb an additional 4 or 5 times.
3. *Starting*  
Lay unit on a flat, clear area and pull starter handle/rope (D) until engine fires.

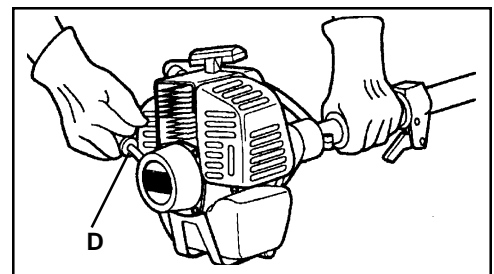
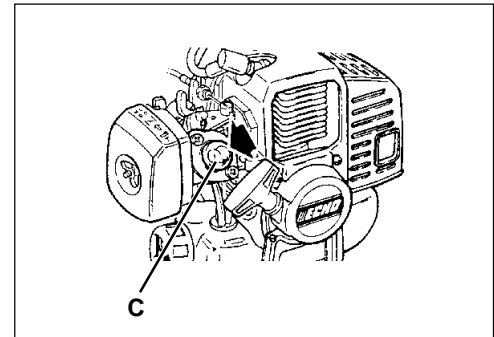
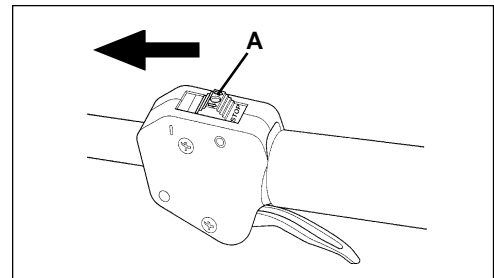

## STOPPING ENGINE

1. Release throttle and allow engine to return to idle before shutting off engine.
2. Move Stop Switch button (A) backward to STOP position.

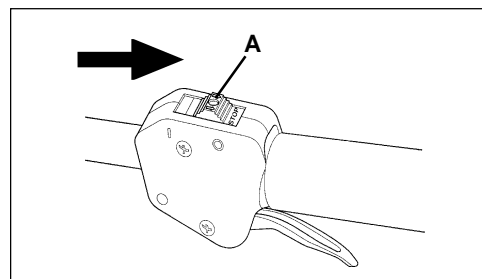

### WARNING DANGER

If engine does not stop when stop switch is moved to STOP position, close choke - COLD START position - to stall engine. Have your ECHO dealer repair stop switch before using hedge clipper again or serious personal injury may result.

## MAINTENANCE

Your ECHO product is designed to provide many hours of trouble free service. Regular scheduled maintenance will help achieve that goal. If you are unsure or are not equipped with the necessary tools, you may want to take your unit to an ECHO Service Dealer for maintenance. To help you decide whether you want to DO-IT-YOURSELF or have the ECHO Dealer do it, each maintenance task has been graded. If the task is not listed, see your ECHO Dealer for repairs.

### SKILL LEVEL

- Level 1**= Easy to do. Most required tools come with unit.
- Level 2**= Moderate difficulty. Some specialized tools may be required.
- Level 3**= Experience required. Specialized tools are required. ECHO recommends that the unit be returned to your ECHO dealer for service.

ECHO offers **REPOWER™** Maintenance Kits and Parts to make your maintenance job easier. Just below each task heading are listed the various part numbers required for that task. See your ECHO dealer for these parts.

## MAINTENANCE INTERVALS

COMPONENT/ SYSTEM	MAINTENANCE PROCEDURE	REQ'D SKILL LEVEL	DAILY OR BEFORE USE	EVERY REFUEL	3 MONTHS OR 90 HOURS	6 MONTHS OR 270 HOURS	YEARLY 600 HOURS
<b>Recommended Echo Dealer Maintenance Procedures</b>							
Cylinder Exhaust Port	Inspect/Clean/Decarbon	3			I / C		
Sharpen Blades	Inspect/Clean	3	I (3)				
<b>Do-It-Yourself Maintenance Procedures</b>							
Air Filter	Inspect/Clean/Replace	1	I / C		R*		
Choke	Inspect/Clean	2	I / C				
Fuel Filter	Inspect/Replace	1			I		R *
Fuel System, leaks	Inspect/Replace	1	I *	I			
Cooling System	Inspect/Clean	2	I / C				
Muffler Spark Arrestor	Inspect/Replace	2			I / R *		
Drive Shaft	Grease	2	I (1)				
Gear Housing	Grease	2	I (2)				
Blades	Inspect/Clean	1	I / C (3)				
Recoil Starter Rope	Inspect/Clean	1	I / C *				
Spark Plug	Inspect/Clean	2			I / C	R *	
Screws/Nuts/Bolts	Inspect/Tighten/Replace	1	I / R *				

**MAINTENANCE PROCEDURE LETTER CODES: I = INSPECT, R = REPLACE, C = CLEAN**

**IMPORTANT NOTE** - Time intervals shown are maximum. Actual use and your experience will determine the frequency of required maintenance.

**MAINTENANCE PROCEDURE NOTES:**

(1) Apply ECHO<sup>®</sup> LUBE™ every 25 hours.

(2) Apply ECHO<sup>®</sup> LUBE™ every 15 - 25 hours

(3) Inspect blade and clean and sharpen as needed. Lubricate blades periodically during use.

\* All recommendations to replace are based on the finding of damage or wear during inspection..

## AIR FILTER

### Level 1.

*Tools required:* 25 or 50 mm (1 or 2 in.) medium bristle paint brush

*Parts required:* 90008 REPOWER™ Air & Fuel Filter Kit

1. Close choke (Cold Start Position). This prevents dirt from entering the carburetor throat when the air filter is removed. Brush accumulated dirt from the air cleaner area.
2. Remove the air cleaner cover. Clean and inspect the element for damage. If element is fuel soaked and very dirty, replace.
3. If element can be cleaned and reused, be certain it:
  - properly fits the cavity in the air cleaner cover.
  - is installed with the original side out.

#### NOTE

Carburetor adjustment may be needed after air filter cleaning/replacement. See Carburetor Adjustment Section.

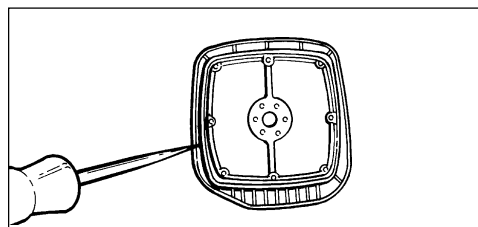
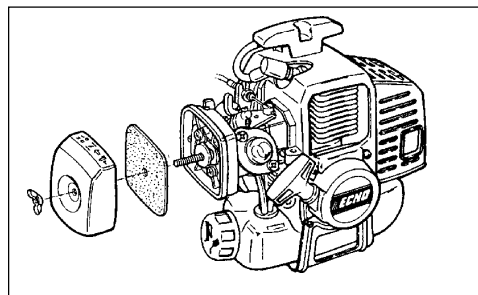
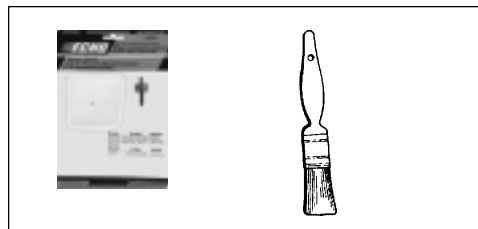

## FUEL FILTER

### Level 1.

*Tools required:* 200-250 mm (8-10 in.) length of wire with one end bent into a hook. Clean rag, funnel, and an approved fuel container

*Parts required:* 90008 REPOWER™ Air & Fuel Filter Kit

#### WARNING DANGER

Fuel is **VERY** flammable. Use extreme care when mixing, storing or handling or serious personal injury may result.

1. Use a clean rag to remove loose dirt from around fuel cap and empty fuel tank.
2. Use the “fuel line hook” to pull the fuel line and filter from the tank.
3. Remove the filter from the line and install the new filter.

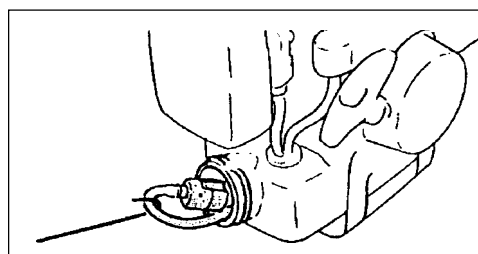
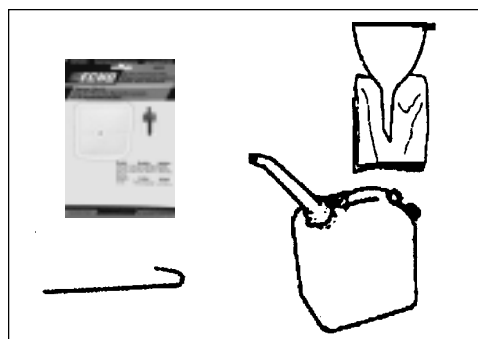

## SPARK PLUG

### Level2.

*Tools Required:* T-Wrench. Feeler gauge, preferably a wire gauge.  
Brush.

*Parts Required:* Spark Plug, NGKBPM-7A P/N 15901010630

1. Remove spark plug and check for fouling, worn and rounded center electrode.
2. Clean the plug or replace with a new one. DO NOT sand blast to clean. Remaining sand will damage engine.
3. Adjust spark plug gap by bending outer electrode.
4. Tighten spark plug to 145-155 kg/cm (125-135 in. lb.).

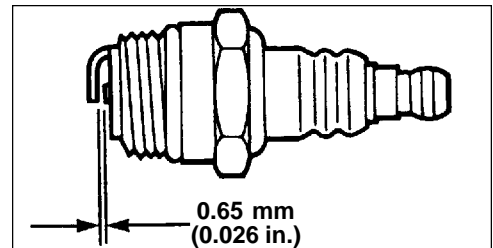
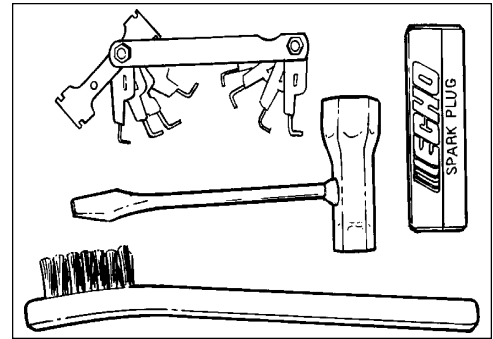

## COOLING SYSTEM CLEANING

### Level3.

*Tools required:* Cross Head Screwdriver, 3 mm Hex wrench, 4 mm Hex wrench, Pointed Wood Stick, Cleaning Brush, 25 or 50 mm (1 or 2 in.) medium bristle paint brush.

*Parts Required:* None.

#### **IMPORTANT**

To maintain proper engine operating temperatures, cooling air must pass freely through the cylinder fin area. This flow of air carries combustion heat away from the engine.

Overheating and engine seizure can occur when:

- Air intakes are blocked, preventing cooling air from reaching the cylinder.
- Dust and grass build up on the outside of the cylinder. This build up insulates the engine and prevents the heat from leaving.

Removal of cooling passage blockages or cleaning of cooling fins is considered "Normal Maintenance". Any failure attributed to lack of maintenance is not warranted.

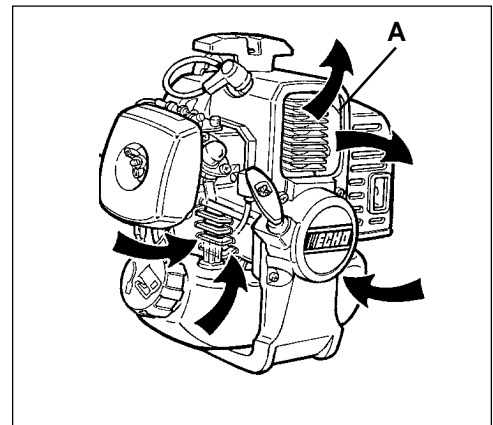
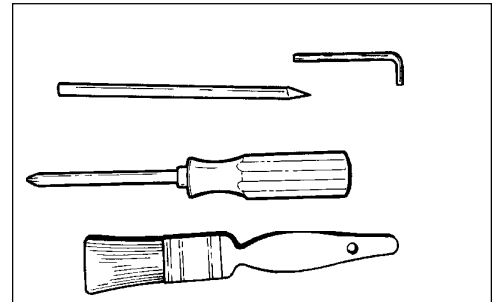

1. Remove spark plug lead from the spark plug and throttle linkage end from the carburetor swivel.
2. Remove the four screws that retain the engine cover. Two at the top of the starter, two on either side of the front. Lift the cover from the engine and lay to the front of the hedge clipper.

**NOTE**

The throttle linkage remains assembled to the engine cover and the spark plug lead and grommet remain installed.

3. Use the wooden stick or brush to remove dirt from the cylinder fins.
4. Remove grass and leaves from the grid between the recoil starter and fuel tank.
5. Assemble components in reverse order.

**NOTE**

When installing the engine cover, be certain the tab of the metal deflector shield is in the slot of the cover.

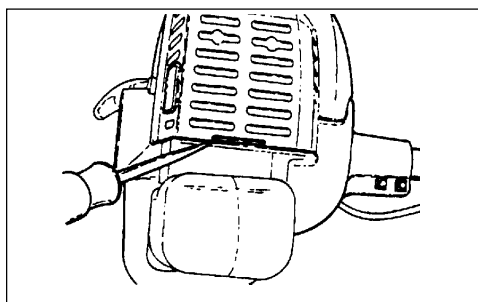
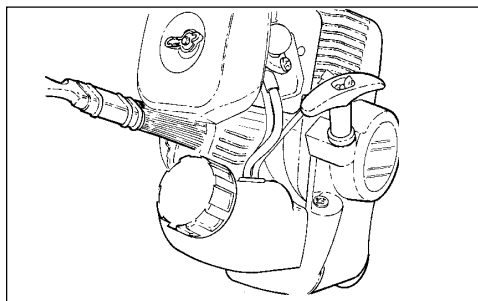
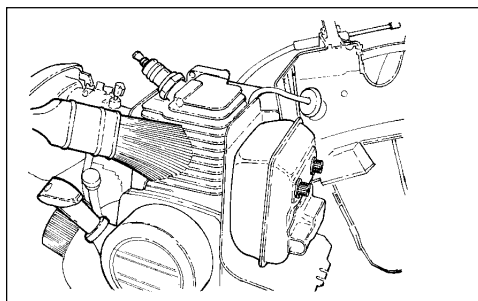

## EXHAUST SYSTEM

### Spark Arrestor Screen

#### Level 2.

*Tools Required:* Cross Head Screwdriver. Soft metal brush.

*Parts Required:* Screen P/N 14586240630, Gasket Lid P/N 14586642031

1. Remove engine cover (A). See "Cleaning Cooling System" pages 17 and 18 for step by step instructions.
2. Place piston at Top Dead Center (TDC) to prevent carbon/dirt from entering cylinder.
3. Remove spark arrestor screen cover (B), screen holder (C), gasket (D) and screen (E) from muffler body.
4. Clean carbon deposits from screen and muffler components.
5. Replace screen if it is cracked, plugged or has holes burned through.
6. Assemble components in reverse order.

**NOTE**

When installing the engine cover, be certain the tab of the metal deflector shield is in the slot of the cover.

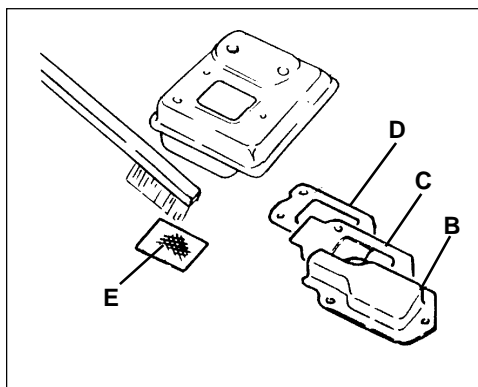
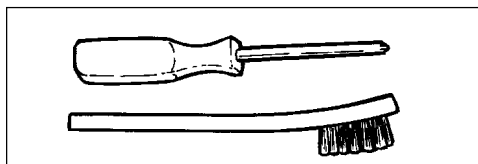

## CARBURETOR ADJUSTMENT

### *Emission Models (with limiter caps)*

#### Level 2.

*Tools required:* Screwdriver, Tachometer (ECHO P/N 99051130017).

*Parts required:* None.

#### **NOTE**

Every unit is run at the factory and the carburetor is set in compliance with emission regulations. In addition, the carburetor is equipped with HI and LO needle adjustment limiters that prevent settings outside acceptable limits.

1. Before adjusting the carburetor, clean or replace the air filter and spark arrester screen.
2. Start engine and run for several minutes to reach operating temperature.
3. Stop engine. Turn HI speed needle (A) CCW (counter clockwise) to stop. Turn LO speed needle (B) midway between full CCW and CW (clockwise) stops.
4. Idle Speed Adjustment.
  - Start engine and turn "idle" speed adjustment screw (C) CW until the blades begin to move, then turn the screw CCW until blades stop moving. Turn screw CCW an additional 1/4 turn.
5. Accelerate to full throttle for 2-3 seconds to clear excess fuel from engine then return to idle. Accelerate to full throttle to check for smooth transition from idle to full throttle. If engine hesitates, turn LO needle (B) CCW an additional 1/8 turn and repeat acceleration. Continue adjusting until smooth acceleration results.
6. Check HI speed RPM at W.O.T. (Wide Open Throttle). HI speed RPM should be set to specifications found on page 9 "Specifications" of this manual.
7. Check idle speed and reset if necessary. If a tachometer is available, idle speed should be set to the specification found on page 9 "Specifications" of this manual.

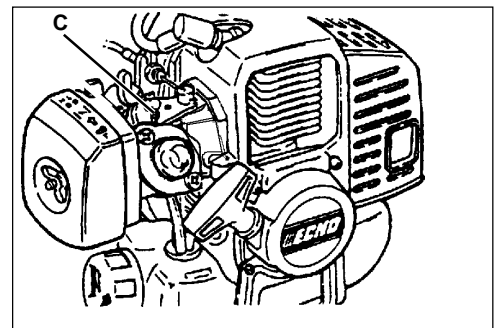
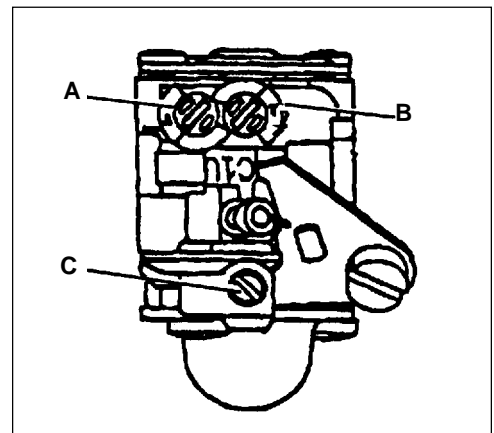
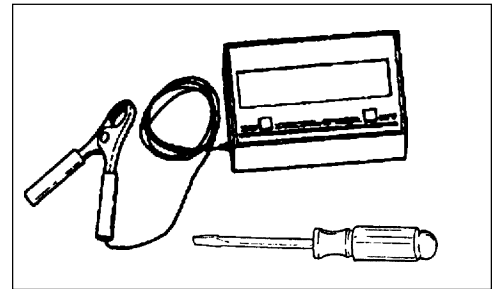

### **WARNING** **DANGER**

When carburetor adjustment is completed, blades should not move at idle, otherwise serious personal injury may result.

## LUBRICATION

### Blades

#### Level 1.

*Tools Required:* Clean Rag, Brush, Oil Can, (2) 10 mm wrenches.

*Parts Required:* 20W Engine Oil (lubrication), 50-50 mixture of kerosene and 20W oil (cleaning).

### WARNING DANGER

Blades are very sharp. Wear gloves to protect hands, otherwise serious personal injury may result.

1. Brush loose debris from blade and coat both sides of blade with the 50-50 cleaning mixture.
2. Allow cleaning mixture to soften the remaining gummy residue then wipe it from the blade.
3. Apply clean oil to the entire length of the blade. Be certain the blade bolts are lubricated.
4. Wipe excess oil from the blade before putting the unit back in service.
5. Check blade tightness. Tighten blade bolts (A) until snug with 10 mm wrench. Loosen bolts 1/2 turn. Hold bolts (A) from turning and tighten locknuts (B) with other 10 mm wrench.

### Gear Case

*Tools required:* Grease Gun with Lithium Grease, Rag.

*Parts required:* ECHO® LUBE™ (P/N 91014) or Lithium Based Grease.

1. Clean dirt from grease fittings.
2. Carefully pump grease in each fitting. **DO NOT** force grease. Too much pressure will force grease past seals and cause damage. **Apply 1-2 pumps of grease every 15-20 hours of operation.** Lubrication should be performed as follows:
  - Commercial Use - Grease weekly or every 25 hours of use.
  - Consumer Use - Grease every 25 hours of use.

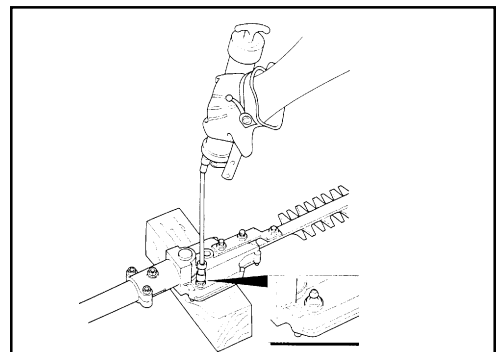
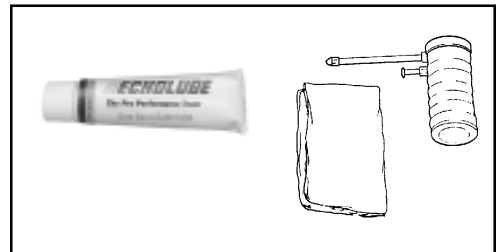
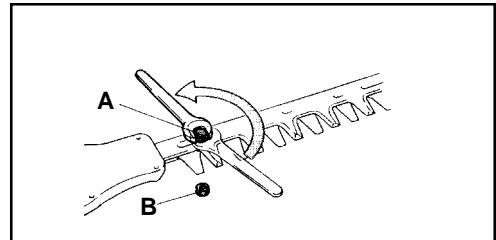
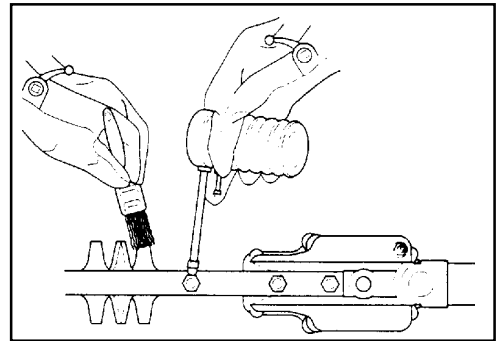
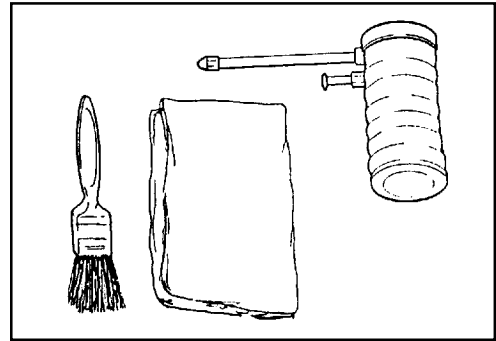

## Drive Shaft Assembly

**NOTE**

Hedge Clipper drive shaft should be greased every 25-50 hours of operation.

*Tools required:* 8 mm Open End Wrench, Screwdriver, Clean Rag, Small Brush.

*Parts required:* ECHO<sup>®</sup> LUBE™ (P/N91014) or Lithium Based Grease.

**WARNING**  **DANGER**

Blades are very sharp. Wear gloves to protect hands, otherwise serious personal injury may result.

1. Loosen gear housing assembly locating screw (A) and mounting screws (C). Remove the gear box from the drive shaft housing.
2. Pull the drive shaft (B) from the housing, wipe clean and re-coat with a thin coating [1/2 oz. (15 ml)] of lithium based grease.
3. Slide the drive shaft back in the drive housing being careful not to get dirt on the flex shaft.
4. Install the gear housing assembly.

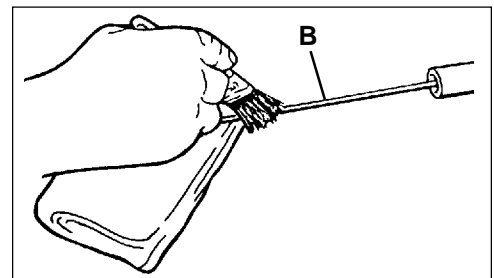
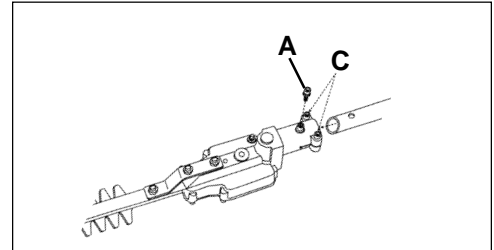
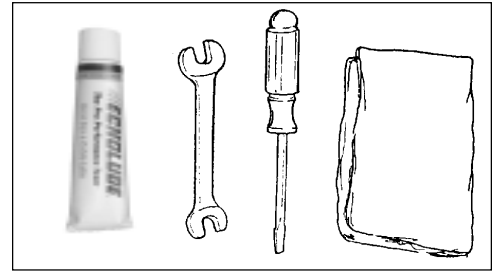

## SHARPENING BLADES

**Level 2.**

*Tools required:* Flat file, Small Screwdriver

*Parts required:* None

**NOTE**

Hedge Clipper Blades are very sharp. Wear gloves to protect hands.

1. Use screwdriver to separate upper and lower cutters equal distance apart.
2. File each edge carefully. Follow the original shape of the blade.

**IMPORTANT**

If a power grinder is used **DO NOT** allow blade to over heat.

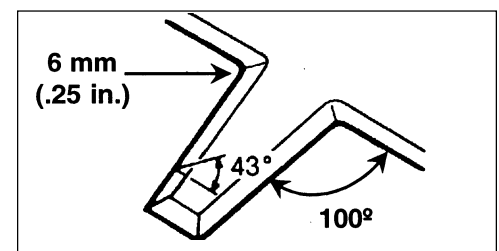
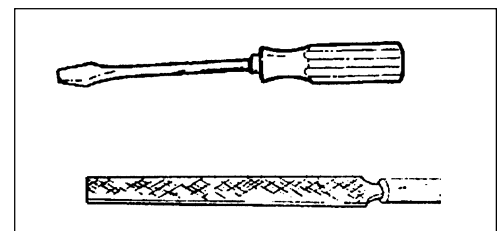

3. Lubricate blades. See "Blade Lubrication Instructions", page 20 this section.

## TROUBLESHOOTING

ENGINE PROBLEM TROUBLESHOOTING CHART				
Problem	Check	Status	Cause	Remedy
Engine cranks - starts hard/ doesn't start	Fuel at carburetor	No fuel at carburetor	Fuel strainer clogged Fuel line clogged Carburetor	Clean or replace Clean or replace See your Echo dealer
	Fuel at cylinder	No fuel at cylinder	Carburetor	See your Echo dealer
		Muffler wet with fuel	Fuel Mixture too rich	Open choke Clean/replace air filter Adjust carburetor See your Echo dealer
	Spark at end of plug wire	No spark	Stop switch off Electrical problem Interlock switch	Turn switch to ON See your Echo dealer See your Echo dealer
	Spark at plug	No spark	Spark gap incorrect Covered with carbon Fouled with fuel Plug defective	Adjust to .65mm (0.026 in.) Clean or replace Clean or replace Replace plug
Engine runs, but dies or does not accelerate properly	Air filter	Air filter dirty	Normal wear	Clean or replace
	Fuel filter	Fuel filter dirty	Contaminants/residues in fuel	Replace
	Fuel vent	Fuel vent plugged	Contaminants/residues in fuel	Clean or replace
	Spark Plug	Plug dirty/worn	Normal wear	Clean and adjust or replace
	Carburetor	Improper adjustment	Vibration	Adjust
	Cooling System	Cooling system dirty/plugged	Extended operation in dirty/dusty locations	Clean
	Spark Arrestor Screen	Spark arrestor screen plugged	Normal wear	Replace
Engine does not crank	N/A	N/A	Internal engine problem	See your Echo dealer

### WARNING DANGER

Fuel vapors are **extremely** flammable and may cause fire and/or explosion. **Never** test for ignition spark near an open spark plug opening, otherwise serious personal injury may result.

## STORAGE

### WARNING DANGER

During operation the muffler or catalytic muffler and surrounding cover become hot. Always keep exhaust area clear of flammable debris during transportation or when storing, otherwise serious personal injury may result.

### *Long Term Storage (over 30 days)*

Do not store your unit for a prolonged period of time (30 days or longer) without performing protective storage maintenance which includes the following:

1. Store unit in a dry, dust free place, out of the reach of children.

### WARNING DANGER

Do not store in enclosure where fuel fumes may accumulate or reach an open flame or spark, otherwise serious personal injury may result.

2. Place the stop switch in the "OFF" position.
3. Remove accumulation of grease, oil, dirt and debris from exterior of unit.
4. Perform all periodic lubrication and services that are required.
5. Tighten all the screws and nuts.
6. **Drain** the fuel tank **completely** and pull the recoil starter handle several times to remove fuel from the carburetor.
7. Remove the spark plug and pour 7 cc (1/4 oz.; 1/2 tablespoon) of fresh, clean, two-stroke engine oil into the cylinder through the spark plug hole.
  - A. Place a clean cloth over the spark plug hole.
  - B. Pull the recoil starter handle 2-3 times to distribute the oil inside the engine.
  - C. Observe the piston location through the spark plug hole. Pull the recoil starter handle slowly until the piston reaches the top of its travel and leave it there.
8. Install the spark plug (do not connect spark plug cable).

#### **IMPORTANT**

Always store and transport Shaft Hedge Clipper in a stable, horizontal position. Support gear case and cutting blades to prevent excessive flexing, which may cause damage to the cutting attachment.

## SERVICING INFORMATION

### PARTS

Genuine ECHO Parts and ECHO REPOWER™ Parts and Assemblies for your ECHO products are available only from an Authorized ECHO Dealer. When you do need to buy parts **always** have the Model Number and Serial Number of the unit with you. You can find these numbers on the engine housing. For future reference, write them in the space provided below.

Model No. \_\_\_\_\_ SN. \_\_\_\_\_

### SERVICE

Service of this product during the warranty period must be performed by an Authorized ECHO Service Dealer. For the name and address of the Authorized ECHO Service Dealer nearest you, ask your retailer or call: 1-800-432-ECHO (3246). Dealer information is also available on our Web Site. When presenting your unit for Warranty service/repairs, proof of purchase is required.

### ECHO CONSUMER PRODUCT SUPPORT

If you require assistance or have questions concerning the application, operation or maintenance of this product you may call the ECHO Consumer Product Support Department at 1-800-673-1558 from 8:30 am to 4:30 pm (Central Standard Time) Monday through Friday. Before calling, please know the model and serial number of your unit to help your Consumer Product Support Representative.

### WARRANTY REGISTRATION

You may register your Echo equipment using the warranty registration card or register on-line at [www.echo-usa.com](http://www.echo-usa.com). Registering provides a direct link between you and ECHO if we find it necessary to contact you.

### ADDITIONAL OR REPLACEMENT MANUALS

**Safety Manuals** in English/Spanish or English/French are available, free of charge, from your ECHO dealer or at [www.echo-usa.com](http://www.echo-usa.com).

**Operator's and Parts Manuals** are available by:

- Downloading free from [www.echo-usa.com](http://www.echo-usa.com)
- Purchasing from your Echo Dealer.
- Sending a check or money order for \$2.00 per Parts Catalog or \$1.50 per Operator's Manual made payable to ECHO, INCORPORATED. State on a sheet of paper the model number and serial number of the ECHO unit you have, part number of the manual (if known), your name and address and mail to address below.

**Safety Videos** are available from your Echo dealer. A \$5.00 shipping charge will be required for each video.

#### Available Parts Catalog

SHC-2100 Type 1/1E      S/N 051701 & Up      Part Number 99922202850

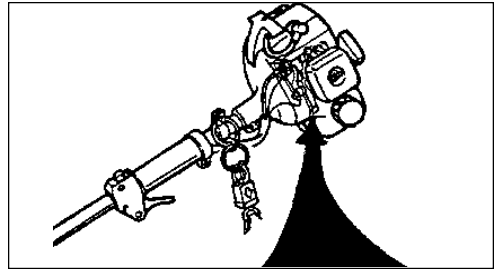

### DEALER?

Call  
**1-800-432-ECHO**  
or  
**[www.echo-usa.com](http://www.echo-usa.com)**

### CONSUMER PRODUCT SUPPORT

**1-800-673-1558**  
**8:30 - 4:30 Mon - Fri C.S.T.**



# ECHO®

**ECHO, INCORPORATED**

400 OAKWOOD ROAD  
LAKE ZURICH, IL 60047

**[www.echo-usa.com](http://www.echo-usa.com)**



**SUPPLEMENT TO OPERATOR'S MANUAL**  
**SUPLEMENTO DEL MANUAL DEL OPERADOR**

*This Supplement contains important information. Please keep with your Operator's Manual.*

*Este suplemento contiene la información importante. Guarde por favor con el manual de su operador.*

MODELS: MODELO:	SERIAL NUMBER NÚMEROS DE SERIE	MANUAL NUMBERS NUMERO DE PIEZA
SHC-2100	0517101 & UP	X7502253400 / X750004210

**IMPORTANT NOTE**

*Manufacturing and packaging improvements made to this unit after your Operator's Manual was printed require that you follow different operating instructions than shown in the manual. These revised instructions are shown below and on the following pages. Please read these instructions carefully, and substitute this new information for the information presently shown in your manual. Please contact us if you have any questions, or if you need help assembling, operating, or maintaining your ECHO equipment. See the back page of your Operator's Manual for detailed instructions on how to contact ECHO Consumer Product Support for help, or how to order additional literature or training videos.*

**DESCRIPTION**

*Page 7 & 8*

- 17. **THROTTLE TRIGGER LOCKOUT** - This lever must be held down during starting. Operation of the throttle trigger is prevented unless throttle trigger lockout lever is depressed.

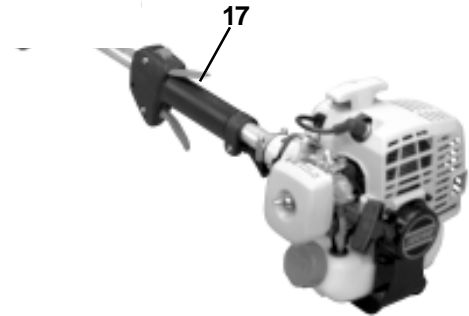

**OPERATION**

*Page 12*

**STARTING COLD ENGINE**

**WARNING  DANGER**

The cutting attachment should not move at idle. If cutting attachment moves, readjust carburetor according to "Carburetor Adjustment" instructions in this manual or see your ECHO Dealer, otherwise serious personal injury may result.

- 1 Stop Switch - Start/Run.  
Move stop switch button (A) forward away from the STOP position.
- 2 Choke - Cold Start.  
Move choke (B) to "Cold Start" Position.
- 3 Primer Bulb - Purge.  
Pump primer bulb (C) until fuel is visible and flows freely in the clear fuel tank return line. Pump bulb an additional 4 or 5 times.

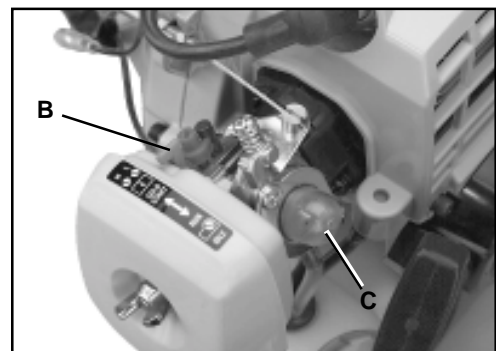
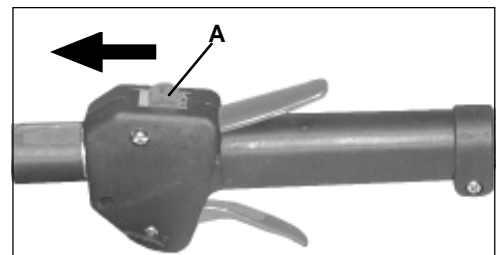

**SUP22203540**

**99922203540**  
**01/02**

**WARNING**  **DANGER**

Inspect starting area for hazards such as rocks, glass, debris etc. which could be contacted by the cutting attachment when starting. Keep helpers and bystanders at least 15 m (50 ft.) from starting area, otherwise serious personal injury may result.

4. Lay the unit on a flat clear area. Firmly grasp right hand grip and throttle trigger lockout with left hand and fully depress throttle trigger to wide open position. Rapidly pull recoil starter handle/rope (D) until engine fires (or maximum five [5] pulls).
5. After engine fires (or five [5] pulls), move choke lever back to "Run" position. Hold throttle trigger and throttle trigger lockout fully depressed and pull recoil starter handle/rope until engine starts and runs. Release throttle trigger and allow unit to warm up at idle for several minutes.

**NOTE**

If engine does not start with choke in "Run" position after 5 pulls, repeat instructions.

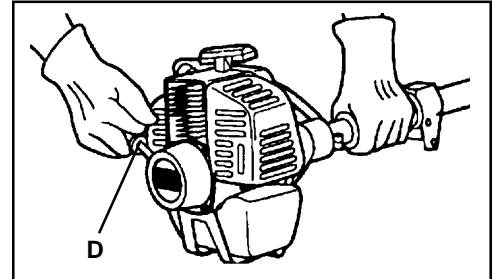

6. After engine warm up, gradually depress throttle trigger to increase engine RPM to operating speed.

**STARTING WARM ENGINE**

The starting procedure is the same as Cold Start except DO NOT close the choke.

**WARNING**  **DANGER**

The cutting attachment should not move at idle. If cutting attachment moves, readjust carburetor according to "Carburetor Adjustment" instructions in this manual or see your ECHO Dealer, otherwise serious personal injury may result.

1. Stop Switch - Start/Run. Move Stop Switch button (A) forward away from the STOP position.
2. Start - Pull Rope. Lay the unit on a flat clear area and pull the recoil starter handle (D) until the engine fires.

**NOTE**

If engine does not start after 5 pulls, use Cold Start Procedure.

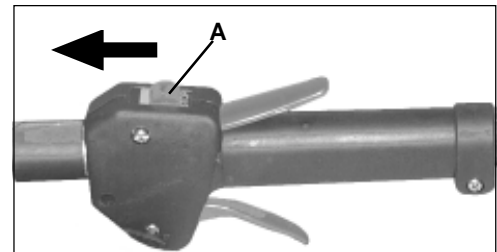

**STOPPING ENGINE**

1. Release Throttle. Allow engine to return to idle before shutting engine off.
2. Stop Switch - Stop. Move stop switch button (A) backward to STOP position.

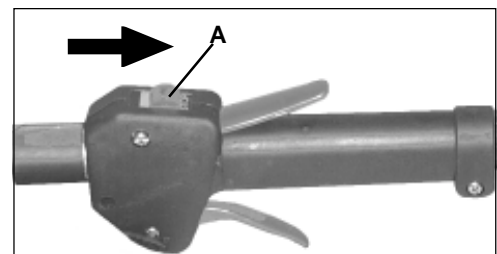

**WARNING**  **DANGER**

If engine does not stop when stop switch is moved to STOP position, close choke - COLD START position - to stall engine. Have your ECHO dealer repair stop switch before using trimmer again.

**NOTE**

Refer to the attachment Operator's Manual and Safety Manual (if included) for proper and safe operating techniques.