

INSTRUCTION MANUAL

CHAIN SAW

CS-520



WARNING

Read the instructions carefully and follow the rules for safe operation.

Failure to do so could result in serious injury.

ECHO, INCORPORATED

400 Oakwood Road, Lake Zurich, Illinois 60047-1564
Phone : 847-540-8400

X750-009 64 0

X750 319-600 0

Printed in Japan 0701Ajb 0045 ES



WARNING



The engine exhaust from this product contains chemicals known to the State of California to cause cancer, birth defects or other reproductive harm.

RULES FOR SAFE OPERATION

A. Kickback Safety Precautions for Chain Saw Users

WARNING!

KICKBACK may occur when the nose or tip of the guide bar touches an object, or when the wood closes in and pinches the saw chain in the cut.

Tip contact in some cases may cause a lightning fast reverse REACTION, Kicking the guide bar up and back towards the operator.

Pinching the saw chain along the top of the guide bar may push the guide bar rapidly back towards the operator.

Either of these reactions may cause you to lose control of the saw which could result in serious personal injury.

The Kick Guard® device is not installed on the guide bar when you purchase your ECHO chain saw.

The Kick Guard® can be used in a majority of cutting operations, and is especially recommended for beginners, homeowners, or chain saw novices.

Most cutting operations can be accomplished with the Kick Guard® in place.

Do not rely exclusively upon the safety devices built into your saw.

As a chain saw user, you should take several steps to keep your cutting jobs free from accident or injury.

1. With a basic understanding of kickback, you can reduce or eliminate the element of surprise. Sudden surprise contributes to accidents.
2. Keep a good firm grip on the saw with both hands, the right hand on the rear handle, and the left hand on the front handle, when the engine is running. Use a firm grip with thumbs and fingers encircling the chain saw handles. A firm grip will help you reduce kickback and maintain control of the saw. Don't let go.
3. Make sure that the area in which you are cutting is free from obstructions. Do not let the nose of the guide bar contact a log, branch, or any other obstruction which could be hit while you are operating the saw.
4. Cut at high engine speeds.
5. Do not overreach or cut above shoulder height.
6. Follow manufacturer's sharpening and maintenance instructions for the saw chain.
7. Only use replacement bars and chains specified by the manufacturer or the equivalent.

B. Other Safety Precautions

1. Do not operate a chain saw with one hand! Serious injury to the operator, helpers, bystanders, or any combination of these persons may result from one-handed operation. A chain saw is intended for two-handed use.
2. Do not operate a chain saw when you are fatigued.
3. Use safety footwear, snug-fitting clothing and protective gloves. Wear eye, hearing, and head protection devices.
4. Use caution when handling fuel. Move the chain saw at least 3 m (10 feet) from the fueling point before starting the engine.
5. Do not allow other persons to be near the chain saw when starting or cutting with the chain saw. Keep bystanders and animals out of the work area.
6. Do not start cutting until you have a clear work area, secure footing, and a planned retreat path from the falling tree.
7. Keep all parts of your body away from the saw chain when the engine is running.
8. Before you start the engine, make sure that the saw chain is not contacting anything.
9. Carry the chain saw with the engine stopped, the guide bar and saw chain to the rear, and the muffler away from your body.
10. Do not operate a chain saw that is damaged, improperly adjusted, or not completely and securely assembled. Be sure that the saw chain stops moving when the throttle control trigger is released.
11. Shut off the engine before setting the chain saw down.
12. Use extreme caution when cutting small size brush and saplings because slender material may catch the saw chain and be whipped toward you or pull you off balance.
13. When cutting a limb that is under tension, be alert for spring-back so that you will not be struck when the tension in the wood fibers is released.
14. Keep the handles dry, clean, and free of oil or fuel mixture.
15. Operate the chain saw only in well ventilated areas.
16. Do not operate a chain saw in a tree unless you have been specifically trained to do so.
17. All chain saw service, other than items listed in the Instruction manual maintenance instructions, should be performed by competent service personnel. (For example, if improper tools are used to remove the flywheel or if an improper tool is used to hold the flywheel in order to remove the clutch, structural damage to the flywheel could occur and could subsequently cause the flywheel to burst.)
18. When transporting your chain saw, use the appropriate guide bar scabbard.
19. Spark arrestor mufflers approved to SAE Standard J335 are standard on ECHO chain saws to reduce the possibility of forest fires. Do not operate the chain saw with a loose or defective muffler. Do not remove the spark arrestor screen.

CONTENTS

RULES FOR SAFE OPERATION	1
SYMBOLS AND SIGNS	3
PACKING LIST	5
NOMENCLATURE OF PARTS	6
OPERATOR SAFETY	8
CORRECT USE OF CHAIN BRAKE	9
PREPARATION FOR USE	10
FUEL AND LUBRICANT	12
OPERATION	14
CUTTING INSTRUCTION	17
CHAIN AND GUIDE BAR COMBINATION	22
MAINTENANCE AND CARE	23
SETTING THE SAW CHAIN	27
TROUBLESHOOTING	29
STORAGE AFTER USE	30
TECHNICAL DATA	30

This chain saw is designed for cutting wood or wood products. Do not cut solid metal, sheet metal, plastic or any non-wood materials.

Specifications, descriptions and illustrative material in this literature are as accurate as known at the time of publication, but are subject to change without notice.

Illustrations may include optional equipment and accessories, and may not include all standard equipment.

SYMBOLS AND SIGNS



DANGER

The safety alert symbol accompanied by the word “DANGER” calls attention to an act or condition which **WILL** lead to serious personal injury or death if not avoided.



CIRCLE AND SLASH SYMBOL

This symbol means the specific action shown is prohibited. Ignoring these prohibitions can result in serious or fatal injury.



WARNING

The safety alert symbol accompanied by the word “WARNING” calls attention to an act or condition which **CAN** lead to serious personal injury or death if not avoided.

NOTE

This enclosed message provides tips for use, care and maintenance of the unit.













CAUTION

The safety alert symbol accompanied by the word “CAUTION” calls attention to an act or condition which may lead to minor or moderate personal injury if not avoided.

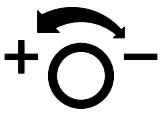
IMPORTANT

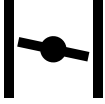
The enclosed message provides information necessary for the protection of the unit.

SYMBOL FORM

Symbol form/shape	Symbol description/application	Symbol form/shape	Symbol description/application
	Carefully read the operator's manual		Chain oil fill
	Wear eyes, ears and head protection		Chain oil pump
	Chain brake operation		Chain oiler adjustment
	Emergency stop		Carburetor adjustment - Low speed mixture
	Choke control "Cold Start" position (choke closed)		Carburetor adjustment - High speed mixture
	Oil and gasoline mixture		Carburetor adjustment - Idle speed

DECALS

Part Number X503-005440

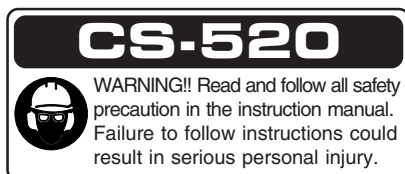

Part Number 890191-30131

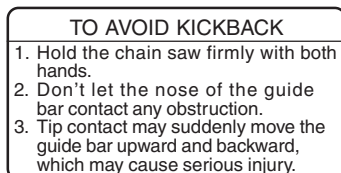

Part Number X524-001650

REPLACEMENT BAR AND CHAIN			
GUIDE BAR*	PART NO.	TYPE	CHAIN* LINKS
16"	16A0MD3366	OREGON 95VP	66
18"	18A0MD3372	OREGON 95VP	72
20"	20A0MD3378	OREGON 95VP	78
*Or equivalent			

Note: There may be other replacement components for achieving kickback protection. For details, please refer to the chain and bar combination sheet shown in the instruction manual.

Part Number X505-002040



Locate this safety decal on your unit. The complete unit illustration found in the "NOMENCLATURE OF PARTS" section will help you locate them. Make sure the decal is legible and that you understand and follow the instructions on it. If a decal cannot be read, a new one can be ordered from your ECHO dealer.

PACKING LIST

The ECHO product you purchased has been factory pre-assembled for your convenience. Due to packaging restrictions, guide bar and saw chain installation and other assembly may be necessary.

After opening the carton, check for damage. Immediately notify your retailer or ECHO dealer of damaged or missing parts. Use the packing list to check for missing parts.

ECHO CHAIN SAW

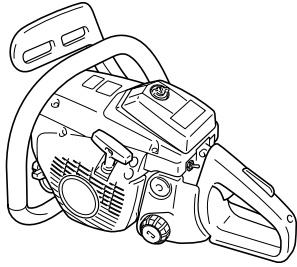

13 x 19 mm T-wrench,
4 mm Hexagonal Wrench,
Small screwdriver

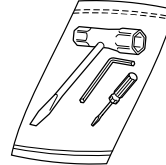

Instruction manual



Safety manual



Spiked bumper,
Bolts 5 x 12 mm

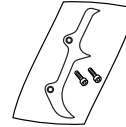

Limited warranty statement

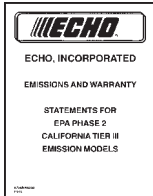

Warranty registration card

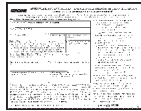

ECHO Power Blend™
2-stroke oil sample



Guide bar



Saw chain



Kick Guard®



NOMENCLATURE OF PARTS

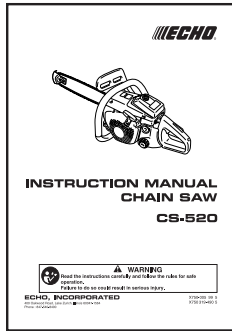

← 1



← 2

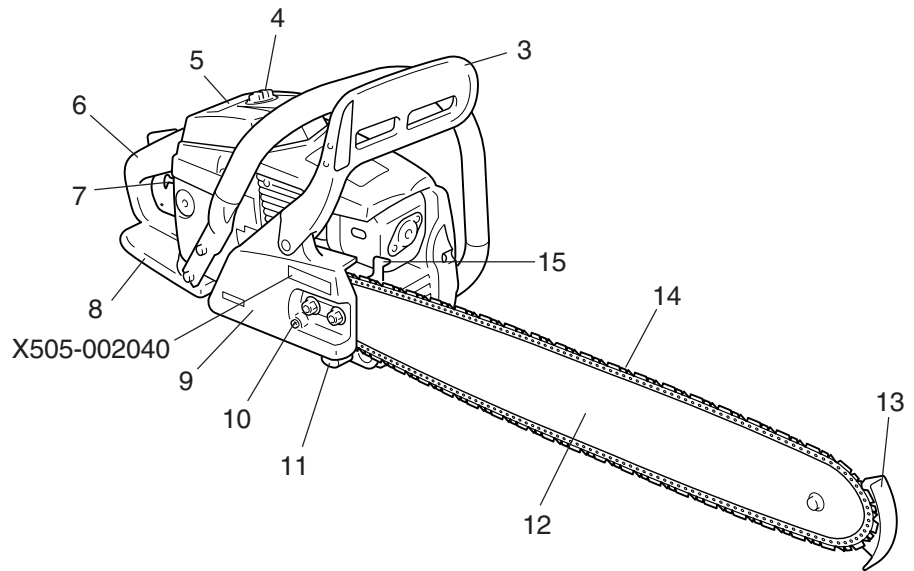

Part Number 890191-30131

TO AVOID KICKBACK

1. Hold the chain saw firmly with both hands.
2. Don't let the nose of the guide bar contact any obstruction.
3. Tip contact may suddenly move the guide bar upward and backward, which may cause serious injury.

Part Number X524-001650

REPLACEMENT BAR AND CHAIN

GUIDE BAR*	CHAIN*	
PART NO.	TYPE	LINKS
16" 16A0MD3366	OREGON 95VP 66	
18" 18A0MD3372	OREGON 95VP 72	
20" 20A0MD3378	OREGON 95VP 78	

*Or equivalent

Note: There may be other replacement components for achieving kickback protection. For details, please refer to the chain and bar combination sheet shown in the instruction manual.

Part Number X503-005440

CS-520



WARNING!! Read and follow all safety precaution in the instruction manual. Failure to follow instructions could result in serious personal injury.

Part Number X505-002040

⚠ WARNING

Chain brake must be unlocked before removing or installing clutch cover. Improper cover installation can result in serious injury and cause severe damage to saw.

El freno de la cadena debe ser bloqueado antes de remover o de instalar la cubierta del embrague. La instalación incorrecta de la cubierta puede dar lugar a lesión seria y causar daño severo a la sierra.

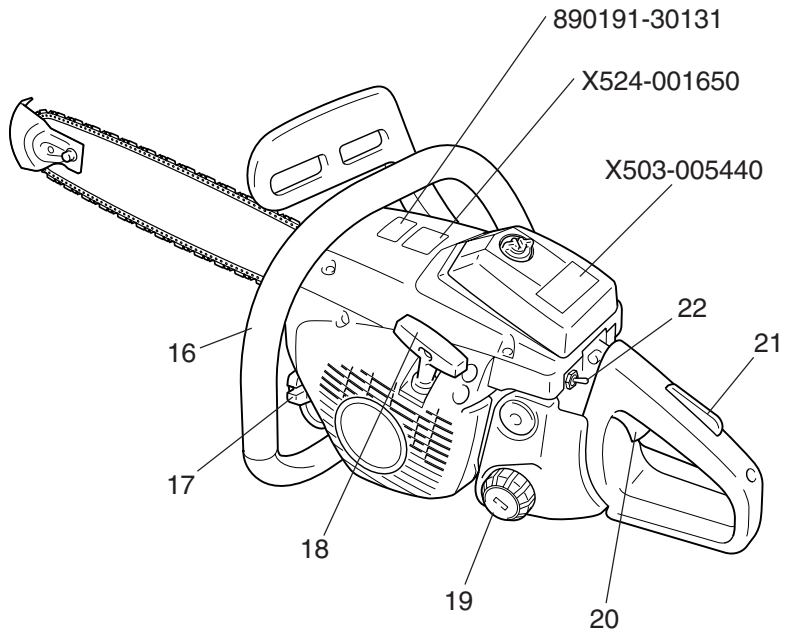

* If a decal cannot be read, a new one can be ordered from your ECHO dealer.

NOMENCLATURE OF PARTS

- 1. Instruction manual** - Included with unit.
Read before operation and keep for future reference to learn proper, safe operating techniques.
- 2. Safety manual** - Describe operating and safety instructions for this chain saw.
- 3. Front hand guard** - Guard between the front handle and the saw chain for protecting the hand from injuries and aiding in control of the chain saw if the hand slips off the handle. This guard is used to lock the chain brake which is to stop the saw chain rotation.
- 4. Cleaner cover knob** - Device for installing the air cleaner cover.
- 5. Air cleaner cover** - Covers air cleaner.
- 6. Rear handle (for the right hand)** - Support handle located towards the rear of the engine housing.
- 7. Choke control knob** - Device for enriching the fuel/air mixture in the carburetor to aid cold starting.
- 8. Rear hand guard** - Extension on the lower part of the rear handle for protecting the hand from the chain if it breaks or degrooves.
- 9. Clutch cover** - Protective cover to the guide bar, saw chain, clutch and sprocket when the chain saw is in use.
- 10. Chain tension adjuster** - Device to adjust chain tension.
- 11. Chain catcher** - A projection designed to reduce the risk of the operator's right hand from being hit by a chain which has broken or derailed from the guide bar during cutting.
- 12. Guide bar** - The part that supports and guides the saw chain.
- 13. Bar tip guard** - Anti-kickback device attached on the bar nose.
- 14. Saw chain** - Chain, serving as a cutting tool.
- 15. Spiked bumper** - Device, fitted in front of the guide bar mounting point, acting as a pivot when in contact with a tree or log.
- 16. Front handle (for the left hand)** - Support handle located at the front of the engine housing.
- 17. Oil tank cap** - For closing the oil tank.
- 18. Starter handle** - Pull handle slowly until starter engages then quickly and firmly. When engine starts, return handle slowly. DO NOT let handle snap back or damage to unit will occur.
- 19. Fuel tank cap** - For closing the fuel tank.
- 20. Throttle trigger** - Device activated by the operator's finger, for controlling the engine speed.
- 21. Throttle trigger lockout** - A safety lever which must be depressed before the throttle trigger can be activated in order to prevent the accidental operation of the throttle trigger.
- 22. Ignition switch** - Device for connecting and disconnecting the ignition system and thus allowing the engine to be started or stopped.

OPERATOR SAFETY

VIBRATION AND COLD

- It is believed that a condition called Raynaud's Phenomenon, which affects the fingers of certain individuals, may be brought about by exposure to vibration and cold.
Exposure to vibration and cold may cause tingling and burning followed by loss of color and numbness in the fingers.
The following precautions are strongly recommended because the minimum exposure which might trigger the ailment is unknown.
- Keep your body warm, especially the head and neck, feet and ankles and hands and wrists.
- Maintain good blood circulation by performing vigorous arm exercises during frequent work breaks and also by not smoking.
- Limit the number of hours of operation.
Try to fill each day with jobs where operating the chain saw, or other hand-held power equipment is not required.
- If you experience discomfort redness and swelling of the fingers, followed by whitening and loss of feeling, consult your physician before further exposing yourself to cold and vibration.

REPETITIVE STRESS INJURY

- It is believed that over-using the muscles and tendons of the finger, hands, arms and shoulders may cause soreness, swelling, numbness, weakness and extreme pain to the areas just mentioned.
Certain repetitive hand activities may put you at a high risk for developing a repetitive stress injury (RSI).
- An extreme RSI condition is Carpal Tunnel Syndrome (CTS) which could occur when your wrist swells and squeezes a vital nerve that runs through the area. Some believe that prolonged exposure to vibration may contribute to CTS. CTS can cause severe pain for months or even years.
To reduce the risk of RSI/CTS, do the following:
 - Avoid using your wrist in a bent, extended or twisted position.
 - Take periodic breaks to minimize repetition and rest your hands.
 - Reduce the speed and force in which you do the repetitive movement.
 - Do exercises to strengthen hand and arm muscles.
 - See a doctor if you feel tingling, numbness or pain in your fingers, hands, wrists or arms.
The sooner RSI/CTS is diagnosed, the more likely permanent nerve and muscle damage can be prevented.

EYE AND HEARING PROTECTION

- Wear eye protection goggles that meet ANSI Z 87.1 requirements.
Goggles meeting the requirements have the mark "Z 87" stamped on them.
- Wear hearing protection.
If this guideline is not followed, hearing loss can occur.
ECHO recommends wearing hearing protection at all times.

WEAR PROPER CLOTHING

- Snug fitting durable clothing should be worn. Pants should have long legs, **DO NOT WEAR SHORTS.**
Do not wear loose fitting clothing, scarves, neckties, jewelry or any item that may become tangled in surrounding growth or the chain saw itself.
- Wear shoes with non-skid soles.
DO NOT wear open toed shoes or operate unit barefooted.
- Wear no-slip, heavy duty work gloves to improve your grip on the chain saw handles.
The gloves also help reduce the transmission of machine vibration to your hands.

HOT HUMID WEATHER

- Heavy protective clothing can increase operator fatigue which may lead to heat stroke.
Schedule heavy work for early morning, or late afternoon hours when temperatures are cooler.

AVOID HOT SURFACES

- During operation, the muffler or catalytic muffler and surrounding cover become hot.
- Never suspend the saw on a lanyard with the engine running.
- Always use the saw from the right-hand side of your body - **NEVER** from the left side.
- Always wear proper safety clothing to protect your lower body from sharp saw chain and hot muffler.
- Always keep exhaust area clear of flammable debris during transportation or when storing, otherwise serious property damage or personal injury may result.

SPARK ARRESTOR MUFFLER

- The spark arrestor muffler controls the exhaust noise and prevents hot, glowing particles of carbon from leaving the muffler. Make sure the spark arrestor screen is in good repair and properly seated in the muffler.
- Certain internal combustion engines operated on forest, brush, and/or grass-covered areas in the states of Washington, Oregon, Idaho, California, Minnesota, New Jersey and Maine, are required to be equipped with a spark arrestor.

This requirement also applies to all U.S. Forest Service lands.

In some of these areas, the spark arrestor system must be certified per USDA Forest Service Regulation SAE J335.

Check with your local or state authorities for specific regulations in your area.

Failure to follow these requirements is a violation of the law.

CORRECT USE OF CHAIN BRAKE

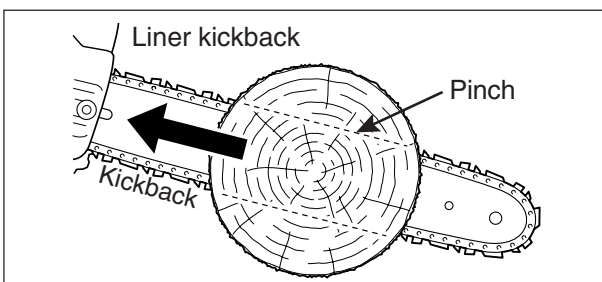
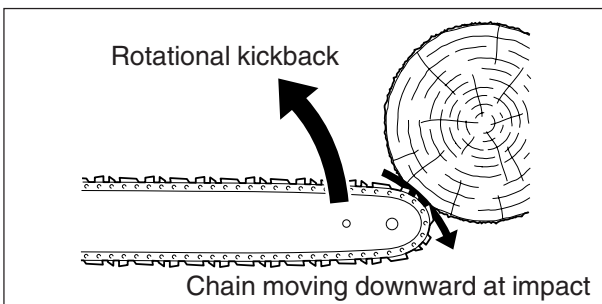
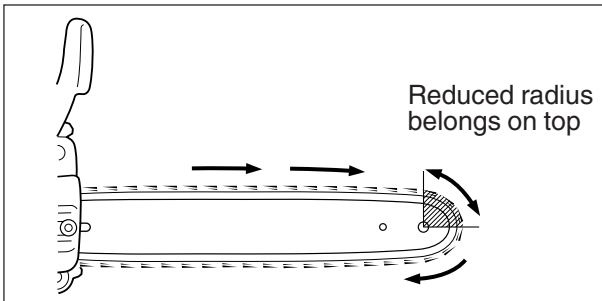
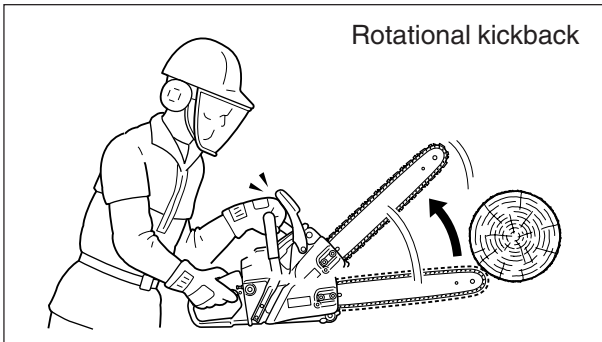

⚠ DANGER

Kickback safety precaution for chain saw users: Kickback may occur when the nose or tip of the guide bar touches an object or when the wood closes in and pinches the saw chain in the cut.

The installation of a chain brake may be mandatory by law or as stipulated by insurance regulations in your area of operation.

You should inquire through local government offices, your employer or your local dealer to ensure that your chain saw conforms to the required safety standard.

ECHO chain brakes have been designed and tested to comply with international safety standards as follows.

USA : ANSI Standard B175.1 - 2000
Safety Requirement for chain saws

Canada : CSA Standard Z 62.1 CHAIN SAWS

⚠ WARNING

ANSI Standard B175.1 - 2000 stipulates that the brake shall stop the chain 0.12 seconds at an engine speed of 13500 r/min. It is the responsibility of the owner/operator to ensure that the brake is serviced, adjusted and tested strictly in accordance with the instructions as detailed herein in order to ensure that the brake performance is maintained in compliance with the Standard B175.1 - 2000.

PREPARATION FOR USE

WARNING

Saw Chain is sharp! Always wear gloves when handling assembly, otherwise serious personal injury may result.

KICK GUARD® TO BAR INSTRUCTIONS

Tools Needed: Two 11 mm (7/16 in.) Wrenches.

For saws with Kick Guard® P/N 2893201 and Symmetrical Low-Kick type (Double Guard) guide bars.

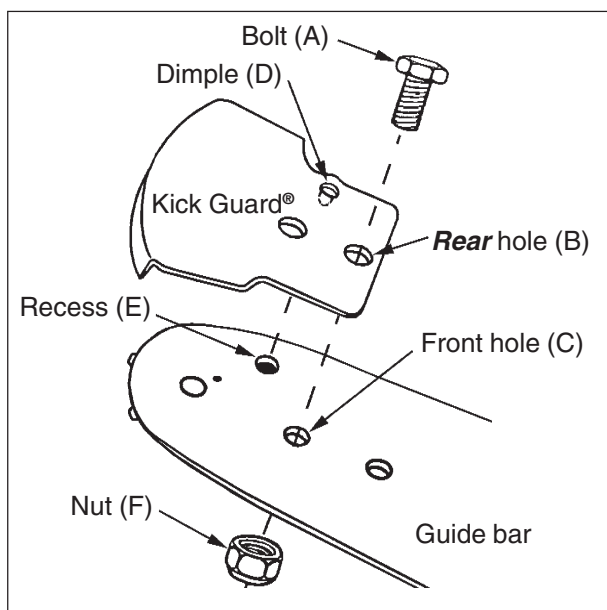

1. Install bolt (A) in *rear* hole (B) of Kick Guard® and through front hole (C) in guide bar.
2. **IMPORTANT:** Dimple (D) in Kick Guard® must engage recess (E) in guide bar.
3. Tighten nut (F) and bolt (A) using 11 mm (7/16 in.) wrenches until snug. Make certain Kick Guard® is flush against guide bar.
4. Tighten nut (F) 1/8 additional turn.
5. Check to make certain Kick Guard® is tight on guide bar.

GUIDE BAR AND SAW CHAIN INSTALLATION/REMOVAL

NOTE

Move the chain brake lever (Front hand guard) fully rearward to remove or install the clutch cover to chain saw.

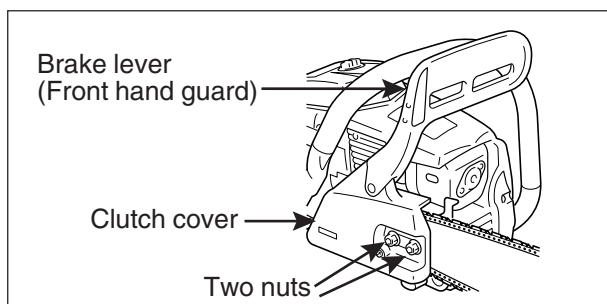

1. Remove spark plug lead. (See page 25)
2. Remove two clutch cover nuts and remove clutch cover.
3. Remove bar and saw chain if necessary. See "Maintenance and Care" section for guide bar/saw chain maintenance procedures.
4. For initial setup, install the spiked bumper on the front of machine with two 5 × 12 mm bolts.

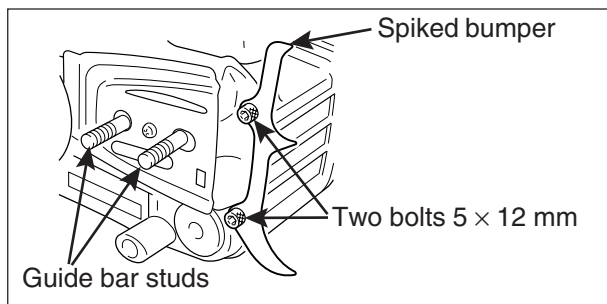

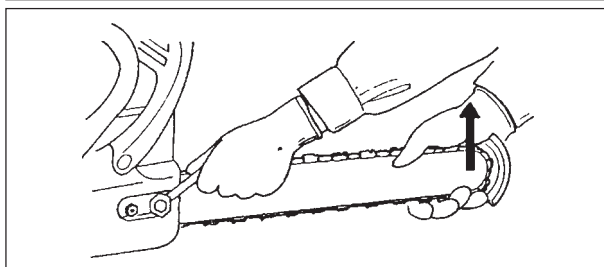
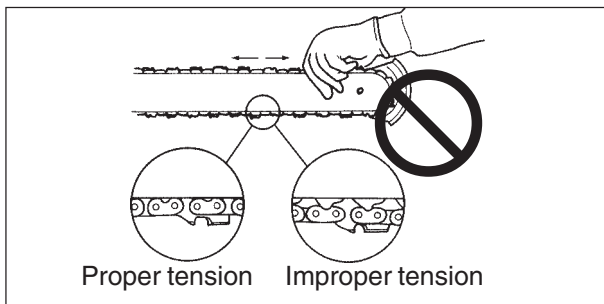
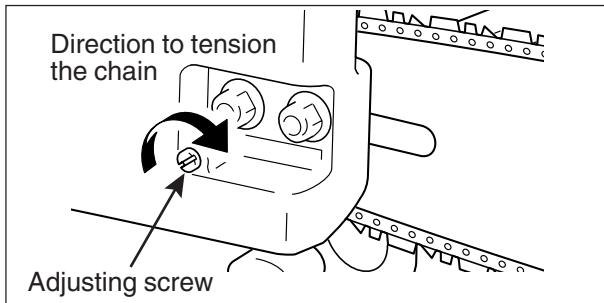
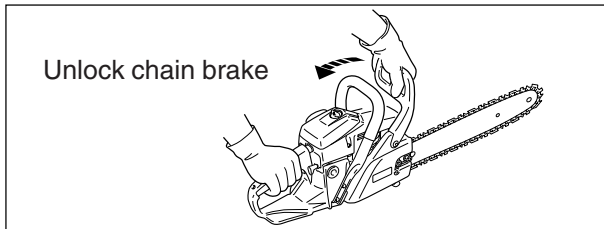
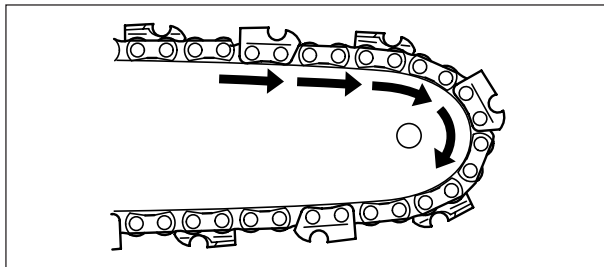
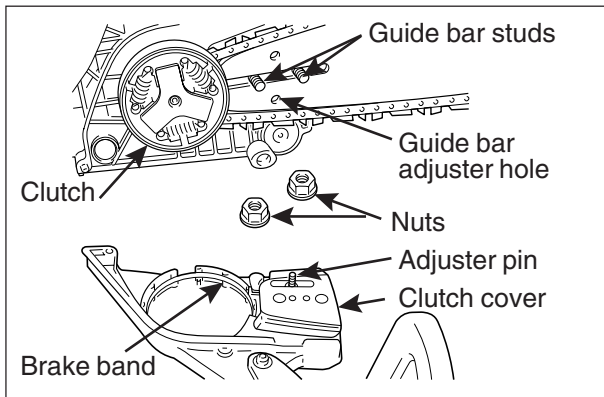

5. Mount guide bar on studs and slide toward clutch to make saw chain installation easier. Install chain with cutters on top of guide bar facing forward.
6. Unlock the chain brake, and install the clutch cover over the guide bar studs. Ensure chain tension adjuster pin fits into the guide bar adjuster hole, brake band is positioned around clutch drum, and tab at rear of clutch cover fits underneath tab on engine cover. Tighten clutch cover nuts finger tight.
7. Turn saw over and check brake band for correct position on clutch drum. If brake band is not in place around drum, remove cover, make sure brake is unlocked, and reinstall. Tighten clutch cover nuts finger tight.

⚠ WARNING

Improper clutch cover assembly can result in serious injury, and will cause severe saw damage if unit is started. Never start or operate saw if brake band is not in place on clutch drum. Always check chain brake operation after replacing cover. Do not use saw if chain brake does not function properly.

ADJUSTING CHAIN TENSION

IMPORTANT
Always loosen clutch cover nuts before turning the chain tension adjuster, otherwise the clutch cover and tensioner will be damaged.

1. Remove spark plug lead. (See page 25)
2. Loosen two clutch cover nuts, if necessary.
3. Hold the bar nose up, and turn the adjuster screw clockwise until chain fits snugly against underside of the bar.
4. Tighten both nuts with the bar nose held up.
5. Pull the chain around the bar by hand. Loosen the adjustment if you feel tight spots.
6. When chain is properly tensioned, tighten clutch cover nuts securely - 20 to 23 N·m (175 to 200 in. lb.).
7. Keep chain properly tensioned at all times.

FUEL AND LUBRICANT



WARNING

Alternative fuels, such as E-20 (20 % ethanol), E-85 (85 % ethanol) or any fuels not meeting above requirements are **NOT** approved for use in ECHO 2-stroke gasoline engines.

Use of alternative fuels may cause performance problems, loss of power, overheating, fuel vapor lock, and unintended machine operation, including, but not limited to, improper clutch engagement.

Alternative fuels may also cause premature deterioration of fuel lines, gaskets, carburetor and other engine components.

Fuel Mix Chart 50 : 1

US.		METRIC	
Gasoline	Oil	Gasoline	Oil
Gallons	US. fl. oz.	L	mL
1	2.6	4	80
2	5.2	8	160
5	12.8	20	400

IMPORTANT

- ECHO premium Power Blend™ Universal 2-Stroke Oil may be mixed at 50 : 1 ratio for application in all ECHO engines sold in the past regardless of ratio specified in those manuals.
- Use of unmixed, improperly mixed, or fuel older than 90 days, (stale fuel), may cause hard starting, poor performance, or severe engine damage and void the product warranty. Read and follow instructions in the Storage section of this manual.

FUEL STATEMENT

GASOLINE - Use 89 Octane [(R+M)/2] (mid grade or higher) gasoline or gasohol known to be good quality.

Gasohol may contain up to 10 % Ethyl (grain) alcohol or 15 % MTBE (methyl tertiary-butyl ether). Gasohol containing methyl (wood) alcohol is **NOT** approved.

TWO-STROKE OIL - A two-stroke engine oil meeting ISO-L-EGD (ISO/CD 13738) and JASO FC Standards must be used. ECHO brand premium Power Blend™ Universal 2-Stroke Oil meets these standards. Engine problems due to inadequate lubrication caused by failure to use an ISO-L-EGD and JASO FC certified oil, such as ECHO premium Power Blend™, will void the two-stroke engine warranty. (Emission related parts only are covered for two years, regardless of two-stroke oil used, per the statement listed in the Emission Defect Warranty Explanation.)



DANGER

Fuel is VERY flammable. Use extreme care when mixing, storing or handling or serious personal injury may result.

- Use an approved fuel container.
- DO NOT smoke near fuel.
- DO NOT allow flames or sparks near fuel.
- Fuel tanks/cans may be under pressure. Always loosen fuel caps slowly allowing pressure to equalize.
- NEVER refuel a unit when the engine is HOT!
- NEVER refuel a unit with the engine running.
- DO NOT fill fuel tanks indoors. ALWAYS fill fuel tanks outdoors over bare ground.
- Securely tighten fuel cap after refueling.
- Inspect for fuel leakage. If fuel leakage is found, do not start or operate unit until leakage is repaired.
- Move at least 3 m (10 feet) from refueling location before starting the engine.

HANDLING FUEL

MIXING INSTRUCTIONS -

1. Fill an approved fuel container with half of the required amount of gasoline.
2. Add the proper amount of two-stroke oil to gasoline.
3. Close container and shake to mix oil with gasoline.
4. Add remaining gasoline, close fuel container, and remix.

IMPORTANT

- Spilled fuel is a leading cause of hydrocarbon emissions. Some states may require the use of automatic fuel shut-off containers to reduce fuel spillage.
- Stored fuel ages. Do not mix more fuel than you expect to use in thirty (30) days, ninety (90) days when a fuel stabilizer is added.
- Stored two-stroke fuel may separate. ALWAYS shake fuel container thoroughly before each use.

AFTER USE -

DO NOT store a unit with fuel in its tank. Leaks can occur. Return unused fuel to an approved fuel storage container.

STORAGE -

Fuel storage laws vary by locality. Contact your local government for the laws affecting your area. As a precaution, store fuel in an approved, airtight container. Store in a well-ventilated, unoccupied building, away from sparks and flames.

Cap indication

Fuel/oil tanks are indicated by the following illustrations.

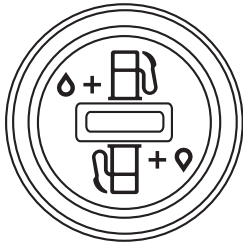

Fuel tank cap

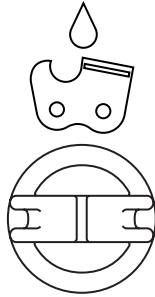

Oil tank cap

CHAIN LUBRICANT

Proper lubrication of the chain while in operation reduces friction between the chain and the guide bar to a minimum and assures a longer service life.

- Use bar and chain oil of high quality for this purpose.
- Do not use used or reclaimed oil to avoid various oiler problems.
- Use ECHO bar and chain oil.
- When ECHO bar and chain oil is not available: Use motor oil, etc.
- Use bar and chain oil of the following grades:
SAE No. 30 in summer
SAE No. 10 in winter or when cutting resinous trees.
- When refueling, also refill chain oil.

OPERATION

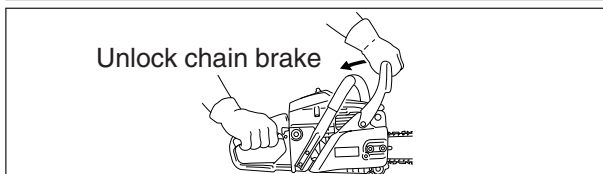
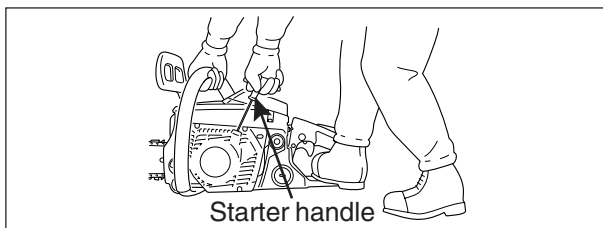
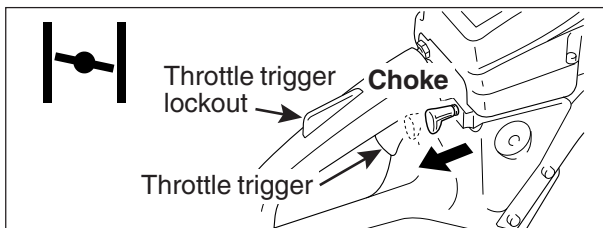
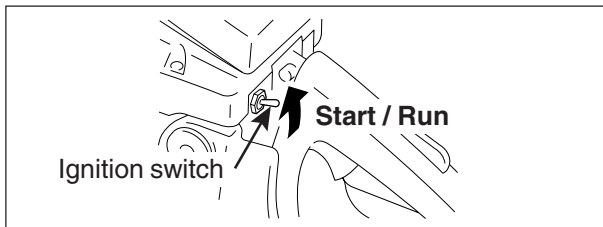
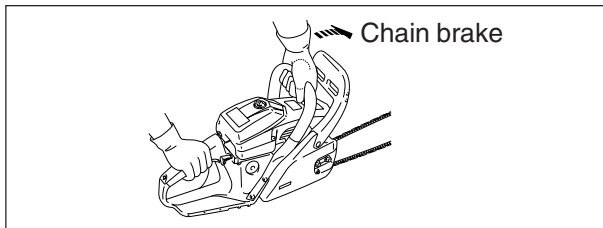

⚠ WARNING

- After choke control knob is pulled and then knob is returned to original position, throttle remains a little open (latch condition).
- If engine is started in this latch condition, chain starts to turn. Do not start engine before chain brake is locked.

⚠ CAUTION

- After starting the engine, squeeze throttle trigger slightly to release throttle latch and pull front hand guard towards the operator immediately. (Chain brake unlocked position)
- Never use throttle latch for cutting.
- Use the chain brake only in starting or in emergencies.

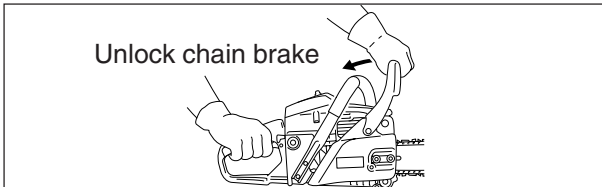
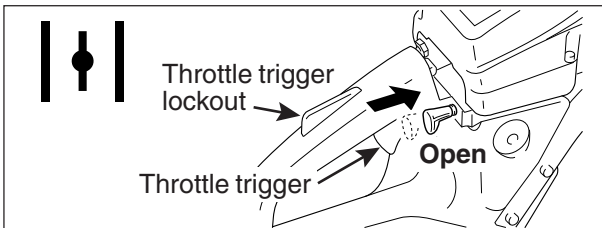
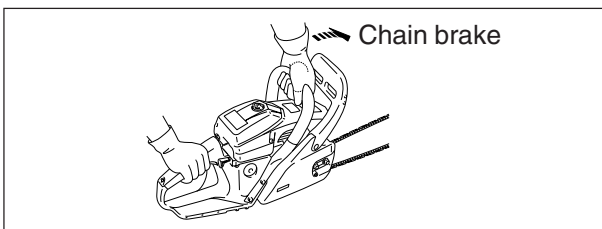
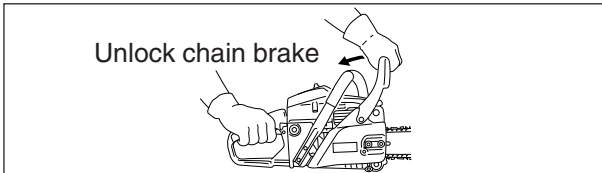
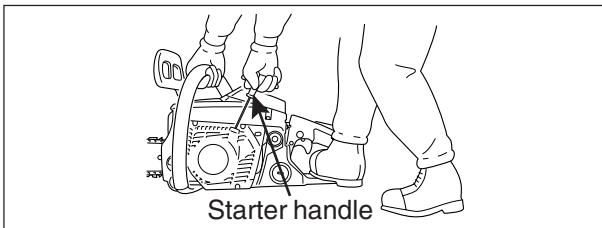
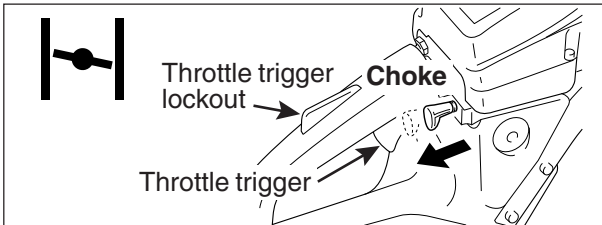
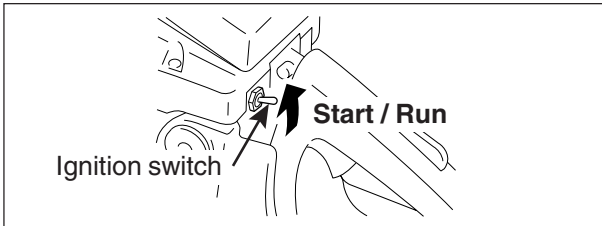
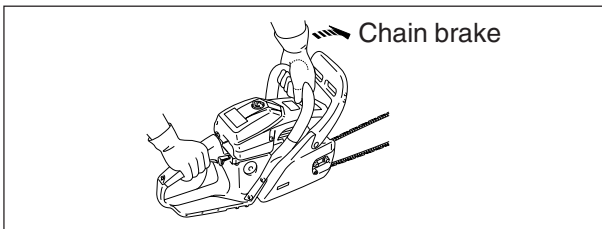

WHEN THE ENGINE IS COLD

CAUTION

Make sure the bar and chain are free from any obstruction when starting the chain saw.

- Move chain brake lever fully forward to lock chain brake before starting.
- Fill the fuel tank with fuel mixture. It is not permitted to fill fuel above the shoulder level of fuel tank.
- Fill the chain oil tank with lubricant. Do not over fill.
- Move ignition switch to "RUN" position.
- Pull choke control knob all the way out. (Choke position)
- Securely hold the chain saw as shown and pull starter handle several times until first firing sound.
- Push choke control knob all the way in.
- Pull starter handle to start the engine.
- When engine starts, immediately squeeze throttle trigger, to release throttle latch, and pull front hand guard towards the operator immediately. (Chain brake unlocked position)

WHEN THE ENGINE IS WARM

CAUTION

Make sure the bar and chain are free from any obstruction when starting the chain saw.

- Move chain brake lever fully forward to lock chain brake before starting.
- Confirm there is fuel and chain oil in the tanks.
- Move ignition switch to "RUN" position.
- Securely hold the chain saw as shown and pull starter handle.
- Choke may be used if necessary, but after first firing sound, pull throttle trigger to release choke.
- After starting the engine, pull front hand guard towards the operator immediately. (Chain brake unlocked position)

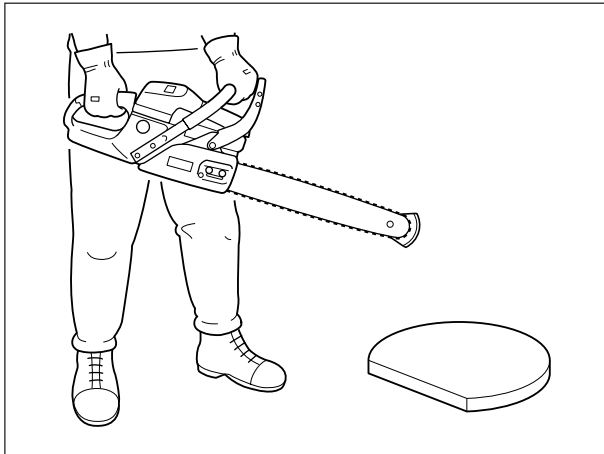

RUNNING

- When engine starts, keep idling for a few minutes.
- Set the brake lever in the unlocked position before starting to cut.
- Pull throttle trigger gradually and increase revolution of the engine.
- The chain starts running when the engine reaches 3800 r/min approximately.
- Confirm proper acceleration and lubrication of chain and bar.
- Do not run the engine at high speed unnecessarily.
- Be sure that saw chain stops moving when throttle trigger is released.

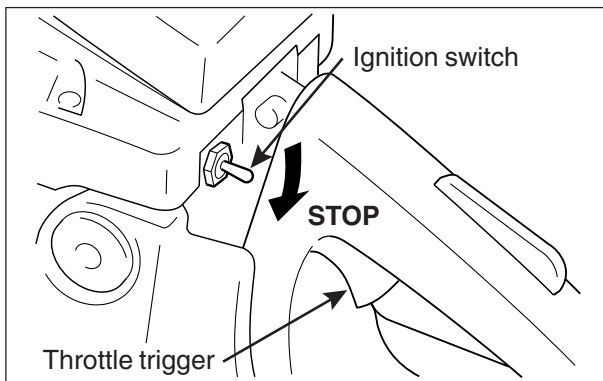

STOPPING

- Release throttle trigger and move ignition switch down to “STOP” position.

NOTE

If engine does not stop, pull choke control knob out fully to stop engine.

Return the unit to your authorized ECHO dealer to check and repair stop switch before starting the engine again.

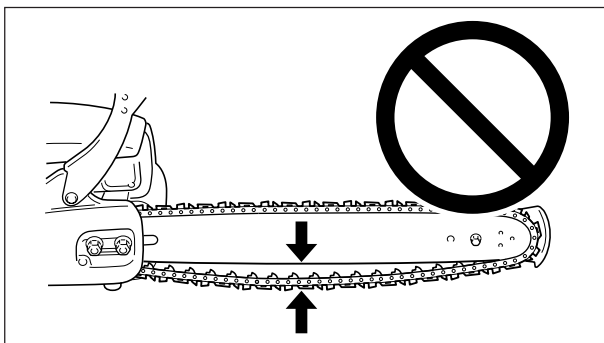

CHECKING CHAIN TENSION

- Chain tension should be checked frequently during work and corrected as necessary.
- Tension the chain as tight as possible, but so it can still be pulled easily along the bar by hand.



CAUTION

Do not operate with a loose chain.

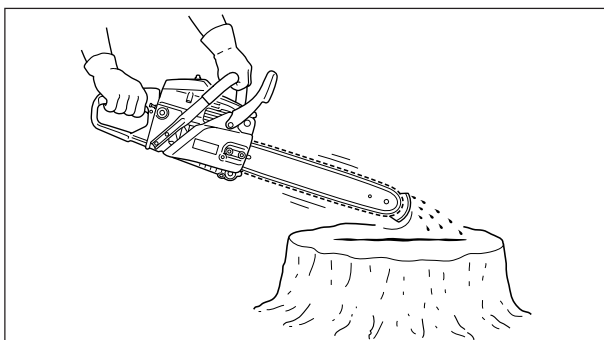

CHAIN LUBRICATION TEST

Hold the chain just above a dry surface and open the throttle to half speed for 30 seconds.

A thin line of “thrown” oil should be seen on the dry surface.

CUTTING INSTRUCTION

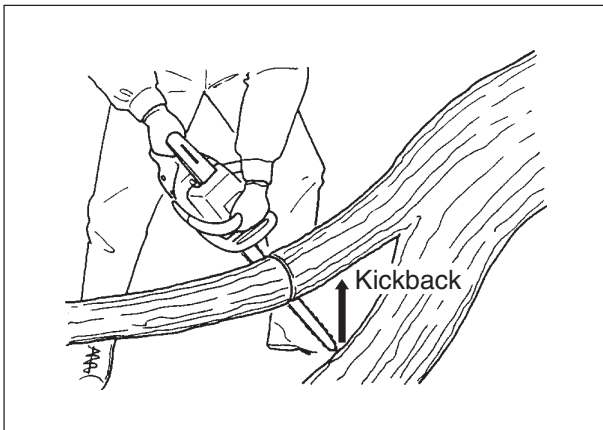
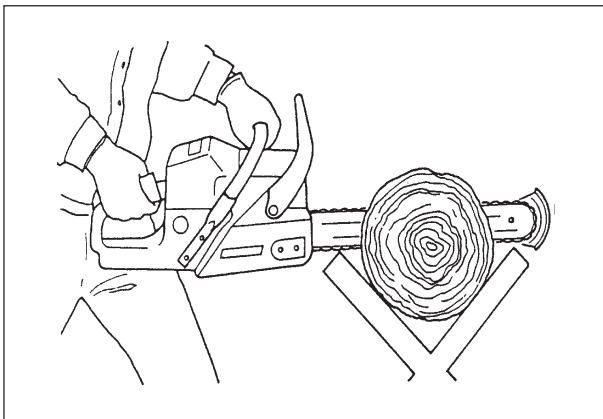
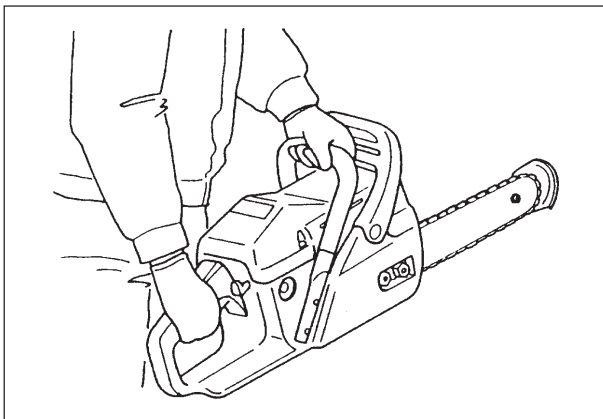
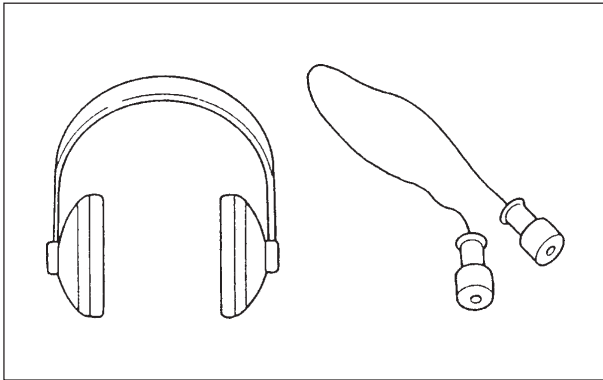

GENERAL

CAUTION

- Read the ECHO "CHAIN SAW SAFETY MANUAL" included with your chain saw for additional cutting and safety instructions.
- Wear suitable hearing protection such as earmuffs or earplugs to protect against objectionable or uncomfortable loud noises.
- Do not let the tip of the bar touch anything while the engine is running.
At cutting speed the chain is moving at a high rate of speed.
Should the tip contact a limb or log while the chain is moving, the tip will be pushed upward with considerable force.
This is known as kickback. Avoid it!

In all circumstances the operation of the chain saw is a one-man job.

It is difficult at times to take care for your own safety, so don't assume the responsibility for a helper as well.

After you have learned the basic techniques of using the saw, your best aid will be your own good common sense.

The accepted way to hold the saw is to stand to the left of the saw with your left hand on the front handlebar and your right hand on the rear handle so you can operate the throttle trigger with your right index finger.

Before attempting to fell a tree, cut some small logs or limbs.

Become thoroughly familiar with the controls and the responses of the saw.

Start the engine, see that it is running properly. Squeeze the trigger to open the throttle wide open and start the cut. If the chain is properly sharpened, the cutting should be relatively effortless.

It is not necessary to press down hard to make the saw cut.

Pushing the saw too hard will slow the engine and cutting will actually be more difficult.

Some material may adversely affect the housings of your chain saw.

(Example palm Tree Acid, fertilizer etc.)

To avoid housing deterioration, carefully remove all packed sawdust around clutch and guide bar area and wash with water. Coat metal parts with light oil.

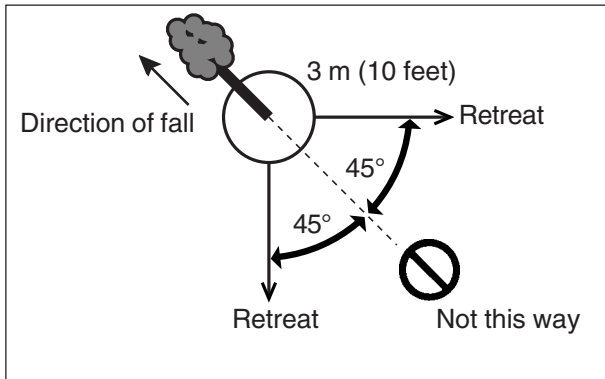

FELLING THE TREE

A falling tree can seriously damage anything it may hit - a car, a house, a fence, a power-line, or another tree.

There are ways to make a tree fall where you want it, so first decide where that is!

Before cutting, clear the area around the tree.

You will need good footing while working and you should be able to work the saw without hitting any obstacles.

Next, select a path of retreat.

When the tree begins to fall you should retreat away from the direction of fall at a 45-degree angle and at least 3 m (10 feet) from the trunk to avoid the trunk kicking back over the stump.

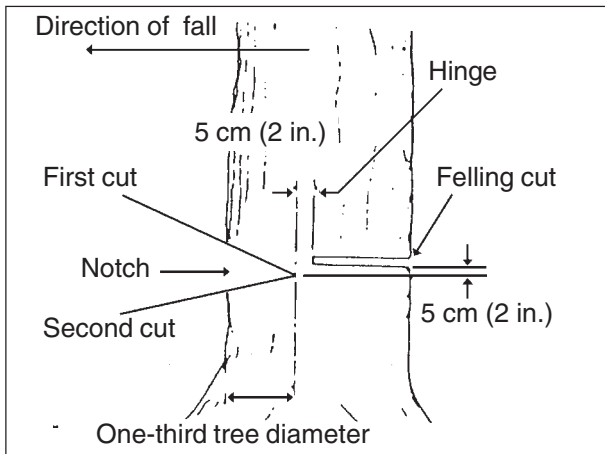

Begin the cut on the side to which the tree is to fall.

Cut a notch about 1/3 of the way into the tree. The position of this notch is important since the tree will try to fall "into" the notch.

The felling cut is made on the side opposite the notch and at a level about 5 cm (2 in.) above the bottom of the notch.

Do not try to cut through to the notch with the felling cut.

The remaining wood between the notch cut and felling cut about 5 cm (2 in.) will act as a hinge when the tree falls, guiding it in the desired direction.

When the tree starts to fall, kill the engine, place the saw on the ground and make your retreat quickly.

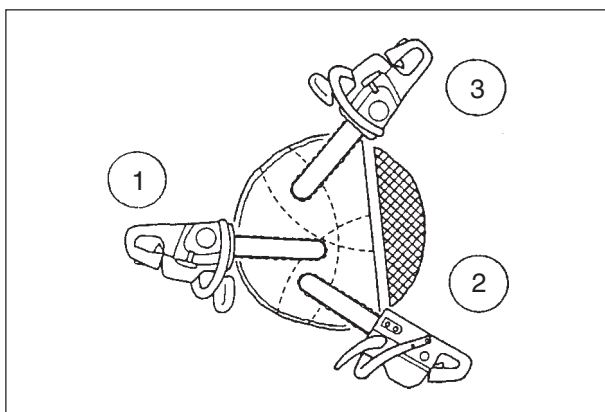

To fell big trees with a diameter exceeding twice the bar length, start the notching cuts from one side and draw the saw through to the other side of the notch.

Start the back cut on one side of the tree, pivoting the saw through to form the desired hinge on that side.

Then remove the saw for the second cut. Insert the saw in the first cut, very carefully so as not to cause kickback.

The final cut is made by drawing the saw forward in the cut to reach the hinge.

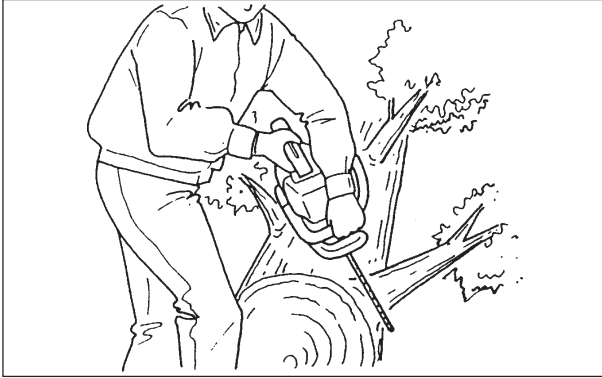

LIMBING

Limbing a fallen tree is much the same as bucking.

Never stand on the tree that you are limbing.

When limbing, caution is the word.

Be careful of the tip touching other limbs.

Always use both hands.

Don't cut with the saw overhead or aligned vertically with your body. If the saw should kickback, you may not have enough control to prevent possible injury.

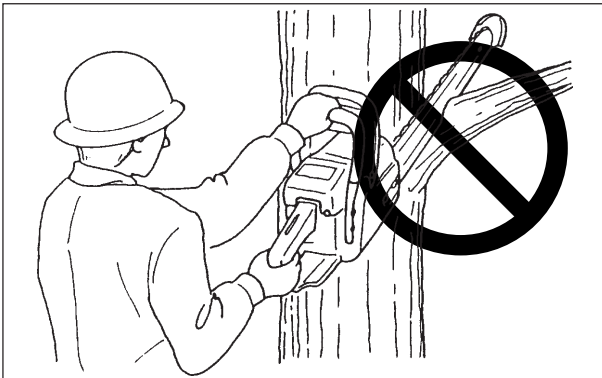

BUCKING

Bucking is the sawing of a log or fallen tree into smaller pieces.

There are a few basic rules which apply to all bucking operations.

Keep both hands on the handles at all times.

Support logs if possible.

When cutting on a slope or hillside, always stand uphill.

Keep in mind that the wood is heavy and that it will bend and pinch the saw if improperly supported.

The trunk will weaken at the point where you make the cut unless the tree is lying on perfectly flat ground or supported as shown.

If you make the cut with the tree on the ground, don't let the saw's chain dig into the earth; it is harmful for the saw, and you stand a good chance of being struck by flying debris.

To cut the trunk, use the bucking and two-cut sequence shown.

The first cut should be no deeper than one-third the trunk diameter.

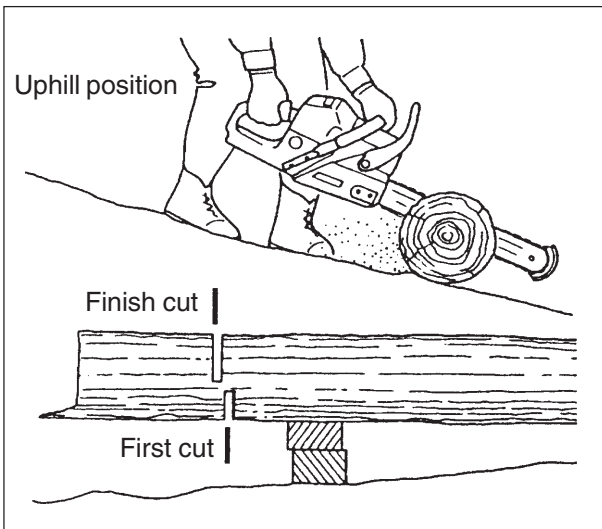

⚠ DANGER

- **Kickback is generated when the rotation of the chain is arrested for some reason. The most dangerous effect of this action occurs when the nose of the bar contacts another object, the chain is momentarily stopped and all the energy of the engine throws the bar upwards and backwards towards the operator.**
- **The chain saw industry and government agencies have attempted to prescribe various safety devices, but the best protection is to avoid kickback.**
- **Comply with the safety precautions as listed in this manual and Safety Manual.**

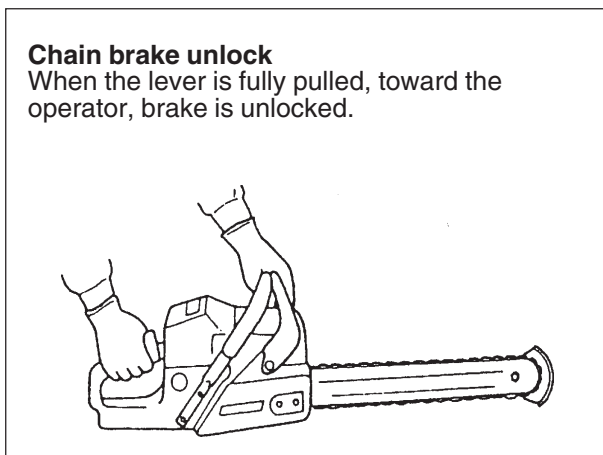
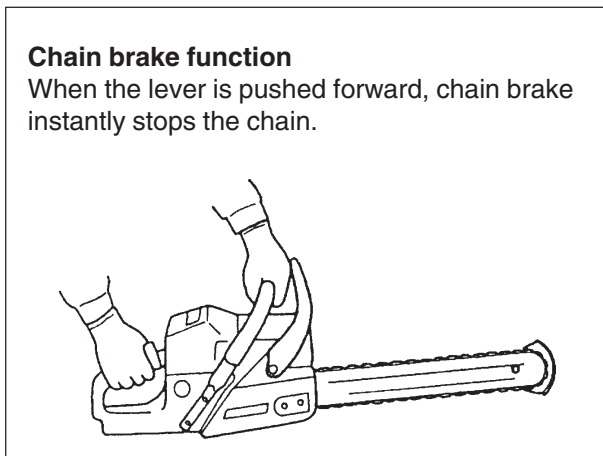
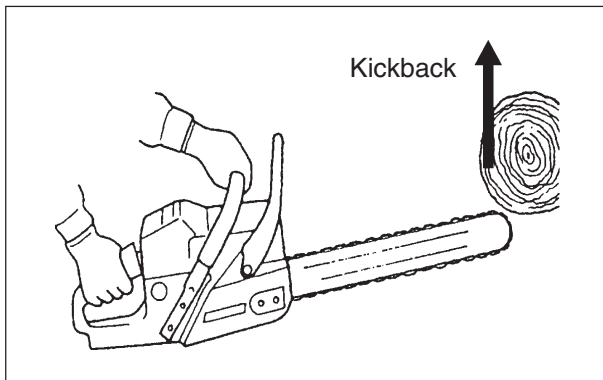
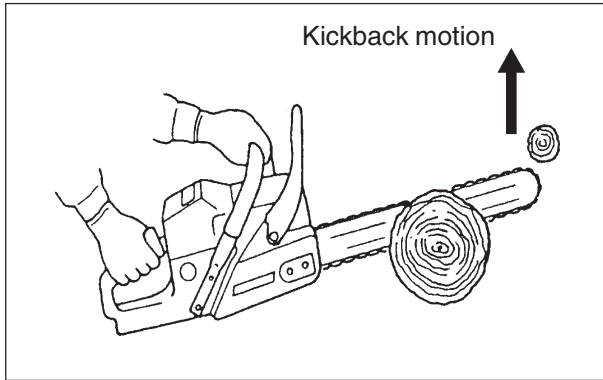

CHAIN BRAKE OPERATION

- Set the lever in the unlocked position before starting to cut.
- If the brake is tripped by kickback reaction, the chain will stop immediately. Release the throttle to avoid possible damage to the engine or clutch.
- Do not attempt to operate the engine with the brake locked.

TESTING THE BRAKE

- Start the engine on a solid level surface and run at a fast idle until warm.
- Hold the saw firmly by the handles and accelerate the engine to a fast idle.
- Slowly operate the chain brake lever while holding the saw firmly on the ground. When the brake lever trips, the chain should stop. Immediately release the throttle trigger.



WARNING

If the chain does not stop immediately, return the saw to your authorized ECHO dealer for repair.

NOTE

- For practice, while cutting a small tree, push the lever forward to lock the brake.
- Confirm that the brake works properly before each use.
- If the chain brake is clogged with wood chips, function of the brake may deteriorate. Always keep the device clean.
- Do not increase engine revolution while the chain brake is locked.
- Use the chain brake only in starting or in emergencies.
- When using throttle latch at starting, keep the chain brake locked. And after starting the engine, unlock the brake immediately.

IMPORTANT

Do not allow the saw to tip forward in order to avoid damage to the chain.

End of the guide bar may be placed at the height of about 35 cm.

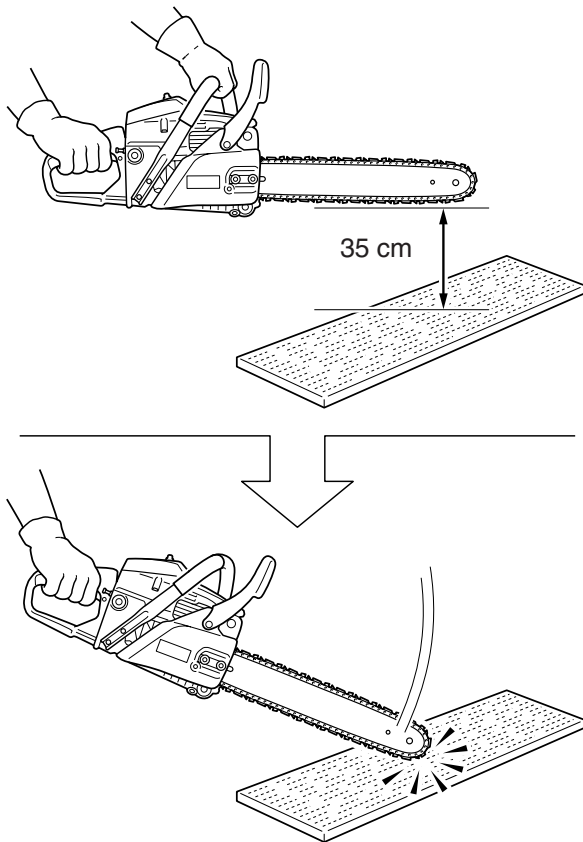

Rear handle should be gripped lightly with the right hand.

AUTOMATIC CHAIN BRAKE

Kickback produced from the tip of the guide bar will trip the automatic chain brake. To make sure that the automatic chain brake operates properly, follow these steps:

1. Stop the engine.
2. Hold the saw with the guide bar approximately 35 cm above a wooden surface. Right hand should hold the rear handle, and left hand should hold the front handle.
3. Release the front handle and drop the end of the guide bar against the wooden surface.
4. The impact should lock the chain brake.

IMPORTANT

When checking the operation of the automatic chain brake, use a soft surface substance like wood to provide the impact so the chain is not damaged.

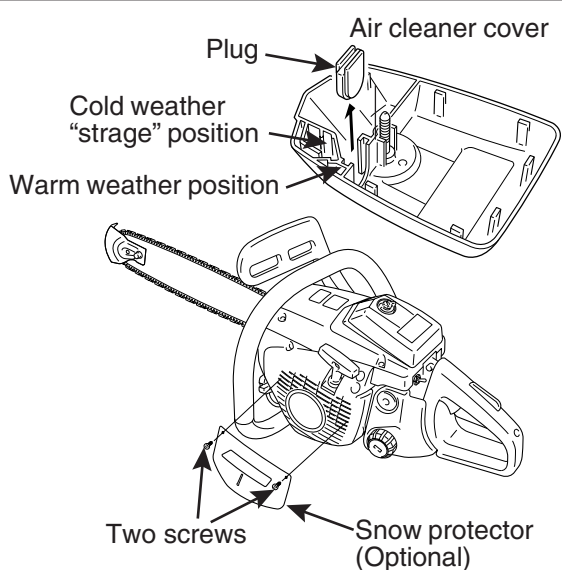

WINTER KIT

Use the winter kit with chain saw to prevent carburetor trouble in the winter.

Install the kit as follows.

- Remove air cleaner cover. Remove plug from warm weather position, and install into cold weather "strage" position.
- Snow protector (Optional)
 - Snow protector prevents snow from getting into the unit through the fan cover. Set the protector hook (2 pieces) to the fan cover. Ensure that the setting direction is correct as shown. Tighten two screws to fasten the snow protector.

NOTE

For operation at normal temperature return the plug to its original place and remove the snow protector. (5°C, 41°F)
It causes over heating of the engine.

CHAIN AND GUIDE BAR COMBINATION

The following combinations are recommended for model CS-520.

Guide Bar		Saw chain		
Length mm (in)	ECHO Part No.	Pitch mm (in)	Type (OREGON)	Links
	Double Guard			
406 (16)	16A0AD3366	8.26 (0.325)	33SL	66
	16A0MD3366	8.26 (0.325)	95VP	66
457 (18)	18A0AD3372	8.26 (0.325)	33SL	72
	18A0MD3372	8.26 (0.325)	95VP	72
@ 508 (20)	20A0AD3378	8.26 (0.325)	33SL	78
	20A0MD3378	8.26 (0.325)	95VP	78

@ Standard configuration

GUIDE BAR

(Low-kickback)

Replacement guide bars.

The following guide bars may be considered to have equivalent kickback energy.

- Sprocket nose guide bars of the same length and nose radius, same pitch and having the same number of teeth.
- Hard nose guide bars of the same length and nose radius as a sprocket nose bar.

SAW CHAIN

(Low-kickback)

CAUTION

Do not use replacement saw chain unless it has been designated as meeting the ANSI B175.1 - 2000 kickback performance requirements, when tested on the representative sample of chain saws below 3.8 c.i.d. specified in ANSI B175.1 - 2000.

NOTE

LOW KICKBACK SAW CHAIN meets the kickback performance requirements of ANSI B175.1-2000 (safety requirements for gasoline-powered chain saws).

MAINTENANCE AND CARE

Your ECHO chain saw is designed to provide many hours of trouble free service. Regular scheduled maintenance will help your chain saw achieve that goal. If you are unsure or are not equipped with the necessary tools, you may want to take your unit to an ECHO Service Dealer for maintenance. To help you decide whether you want to DO-IT-YOURSELF or have the ECHO Dealer do it, each maintenance task has been graded. If the task is not listed ask your ECHO dealer for repairs.

SKILL LEVELS

Level 1 = Easy to do. Most required tools come with unit.

Level 2 = Moderate difficulty. Some specialized tools may be required.

Level 3 = Experience required. Specialized tools are required. ECHO recommends that the unit be returned to your ECHO dealer for servicing.

ECHO offers **REPOWER™** Maintenance Kits and Parts to make your maintenance job easier. Just below each task heading are listed the various part numbers required for that task. Ask your ECHO dealer for these parts.

MAINTENANCE INTERVALS

Component/system	Maintenance procedure	Required Skill level	Daily or Before use	Every refuel	3 Months or 90 Hours	6 Months or 270 Hours	Yearly or 600 Hours
Recommended ECHO Dealer Maintenance Procedures							
Cylinder Exhaust Port	Inspect/Clean/Decarbon	3			I/C		
Do-It-Yourself Maintenance Procedures							
Air Filter	Inspect/Clean/Replace	1	I/C		R*		
Automatic Oiler	Inspect/Adjust	1	I				
Oil Filter	Inspect/Replace	1	I/R*				
Fuel Filter	Inspect/Replace	1			I		R*
Guide Bar and Oil Holes	Inspect/Clean	1	I/C				
Sprocket	Inspect/Replace	2	I/R*				
Spark Plug	Inspect/Clean/Replace	2			I/C	R*	
Cooling System	Inspect/Clean	2	I/C				
Muffler Spark Arrestor	Inspect/Clean/Replace	2			I/R*		
Starter Rope	Inspect/Replace	1	I/R*				
Screws/Nuts/Bolts	Inspect/Tighten/Replace	1	I/R*				

Maintenance Procedure Letter Codes:

I = INSPECT

C = CLEAN

R = REPLACE

* = All recommendations to replace are based on the finding of damage or wear during inspection.

IMPORTANT

Time intervals shown are maximum. Actual use and your experience will determine the frequency of required maintenance.

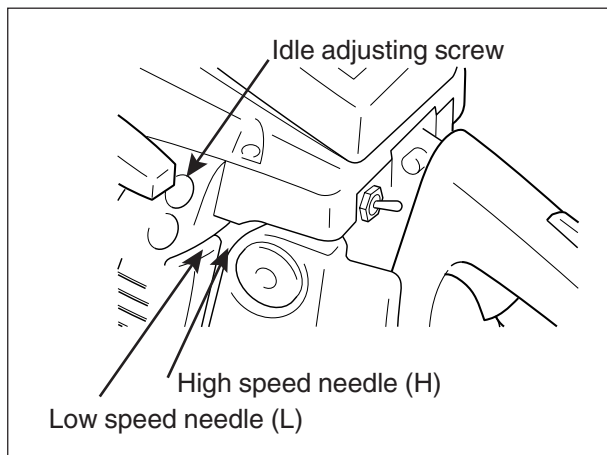

CARBURETOR ADJUSTMENT

Every unit is run at the factory and the carburetor is set in compliance with Emission Regulations. In addition, the carburetor is equipped with "H" (High Speed) and "L" (Low Speed) needle adjustment limiters that prevent settings outside acceptable limits.

1. Before adjusting carburetor clean or replace air filter and muffler "Spark Arrestor Screen".
2. Make sure the bar and chain are properly adjusted.
3. Start engine and run several minutes to bring to operating temperature. Flash choke twice during warm-up to clear any air from the fuel system.
4. Stop engine.
 - Turn "H" speed needle counterclockwise (CCW) to stop.
 - Turn "L" speed needle midway between full clockwise (CW) stop and CCW stop.
5. Idle Speed Adjustment:
 - Start engine, turn "Idle" speed adjustment screw CW until the saw chain begins to turn, then turn screw out CCW until the saw chain stops turning.
 - Turn screw out, CCW, an additional 1/4 turn.



WARNING

Cutting attachment must not move when unit is idling.

6. Accelerate to full throttle for 2 - 3 seconds to clear any excess fuel in the engine, then return to idle.
 - Accelerate engine to full throttle to check for smooth transition from idle to high speed.
 - If engine hesitates turn "L" needle CCW 1/8 turn and repeat acceleration.
 - Continue adjustment until smooth acceleration results.
7. Check idle speed and reset if necessary as described in item 5. If a tachometer is available idle speed should be set to 2900 - 3100 r/min.



CAUTION

When starting, idling adjustment speed should be adjusted not to rotate the saw chain. Correct idle speed is adjusted 2900 to 3100 r/min. Or 1/4 turn CCW from the point the chain stops moving.

When you experience trouble with the carburetor, contact your dealer.

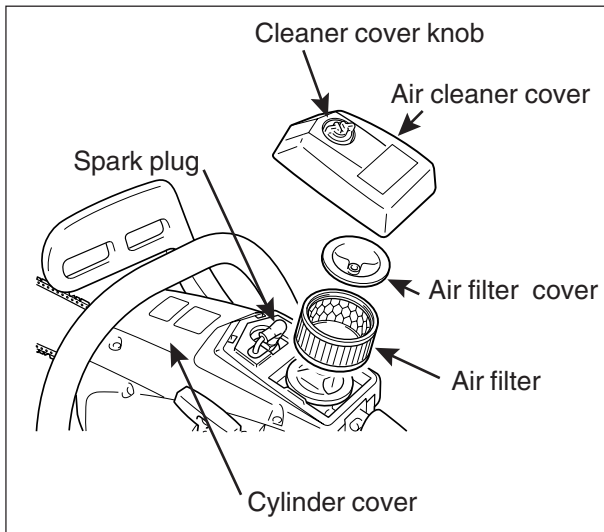

AIR FILTER

- Check before every use.
- Loosen cleaner cover knob and remove air cleaner cover and filter.
- Brush off dust lightly, or clean with compressed air, or replace the air filter.
- Reinstall air filter and cover.

CHECK FUEL SYSTEM

- Check before every use.
- After refueling, make sure fuel does not leak from around fuel pipe, fuel grommet or fuel tank cap.
- In case of fuel leakage there is a danger of fire. Stop using the machine immediately and request your dealer to inspect or replace.

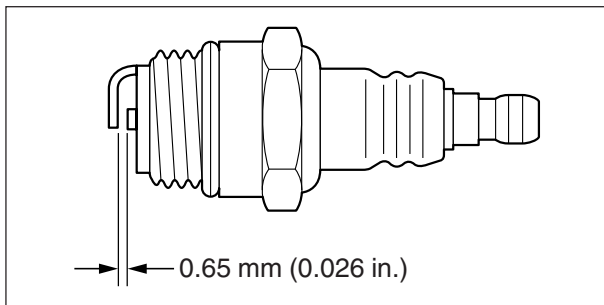

SPARK PLUG

- Check periodically.
- The standard spark gap is 0.65 mm (0.026 in.).
- Correct the spark gap if it is wider or narrower than the standard gap.
- Fastening torque: 15 to 17 N·m (130 to 145 in. lb.).

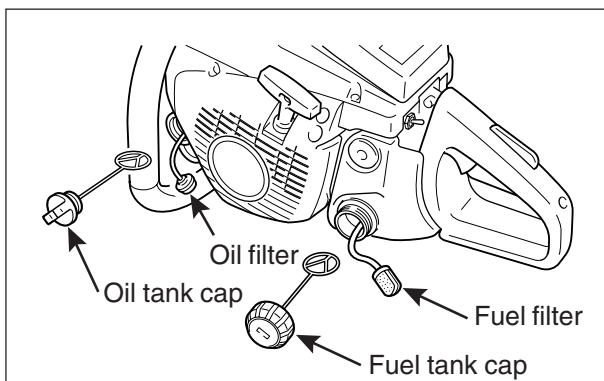

FUEL FILTER

- Check periodically.
- Do not allow dust to enter fuel tank.
- A clogged filter will cause difficulty in starting engine or abnormalities in engine performance.
- Pull the fuel filter out through fuel inlet port with a piece of steel wire or the like.
- When the filter is dirty, replace it.
- When the inside of the fuel tank is dirty, rinsing the tank out with gasoline can clean it.

OIL FILTER

- Check periodically.
- Do not allow dust to enter into oil tank.
- A clogged oil filter will affect the normal lubricating system.
- Pull it out through oil filling hole with a piece of steel wire or the like.
- If the filter is dirty, wash it in gasoline or replace it.
- When the inside of the tank gets dirty, rinsing the tank out with gasoline can clean it.

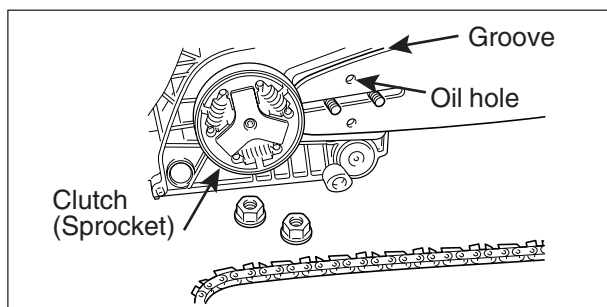

GUIDE BAR

- Clean before using.
 - Clean the groove of the guide bar with a small screwdriver.
 - Clean oil holes with a wire.
- Reverse guide bar periodically.
- Check sprocket and the clutch and clean the bar mount area before installation of the bar. Replace either or both if worn.

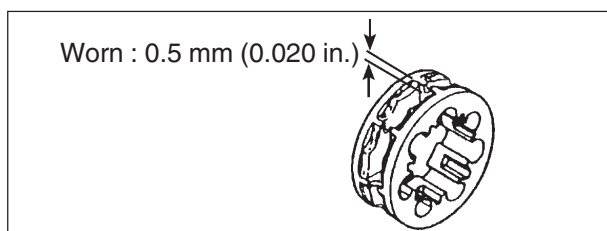

SPROCKET

- A damaged sprocket will cause premature damage or wear of saw chain.
 - When the sprocket has worn out 0.5 mm (0.020 in.) or more, replace it.
- Check sprocket when you install new chain. Replace it if worn.

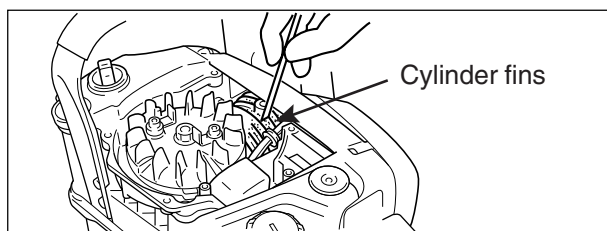

CYLINDER FINS

- Check periodically.
- Clogged fins will result in poor engine cooling.
- Remove dirt and dust from between fins to let cooling air pass easily.

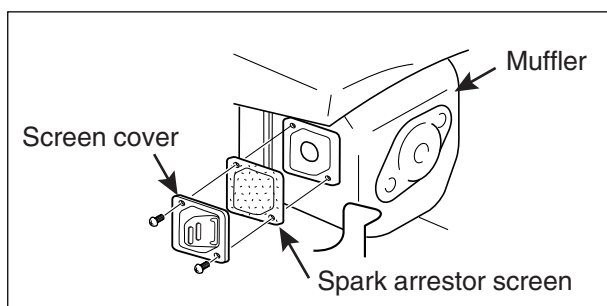

MUFFLER SPARK ARRESTOR

- Remove air cleaner cover and remove spark plug lead.
- Remove spark arrestor screen cover and screen from muffler body.
- Clean carbon deposits from muffler components.
- Replace screen if it is cracked, or has holes burned through.
- Assemble components in reverse order.

NOTE

- Carbon deposits in muffler will cause drop in engine output. Spark arrestor screen must be checked periodically.

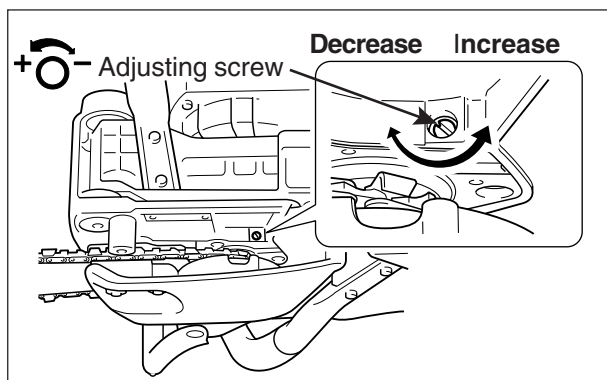

AUTOMATIC OILER

- The discharge volume of the automatic oiler is adjusted to 4 mL/min approximately at 7000 r/min, prior to shipment from factory.
 - To increase the delivery volume, turn the adjusting screw counterclockwise. When the screw touches stopper and stops, this position indicates maximum discharge volume. (13 to 14 mL/min at 7000 r/min)
 - Do not turn the adjusting screw beyond the maximum or minimum limit of volume adjustment.

SETTING THE SAW CHAIN

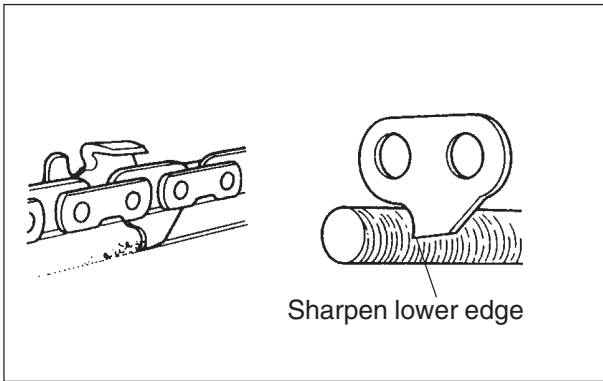
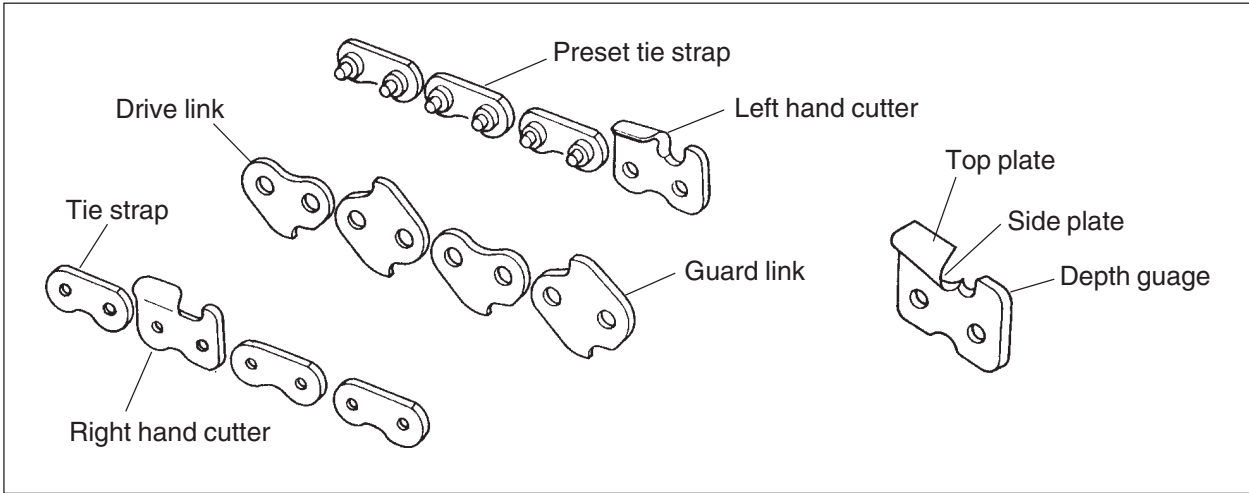

Important points for proper maintenance of saw chain:

- Keep the cutters sharp at all times.
- Keep the left and the right cutters properly aligned.
 - Note that blunt or irregular cutters will result in poor cutting performance, increased vibration of chains and premature breakage of the saw chain.
- Drive link serves to remove sawdust from the groove of the guide bar. Keep the lower edge of the drive link sharp where indicated.

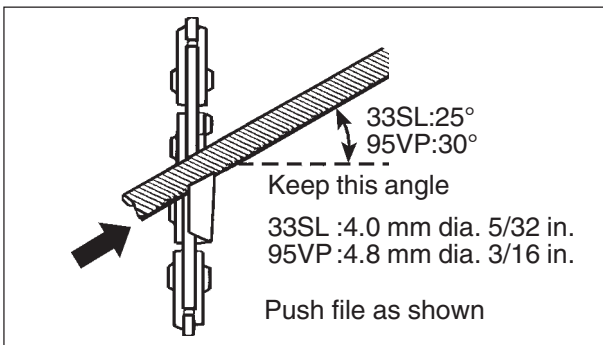

SETTING SAW CHAIN

- For setting saw chain, round file (33SL : 4.0 mm dia. 5/32 in. or 95VP : 4.8 mm dia. 3/16 in.) and flat file are used.
- To keep correct position and correct angle, use the file holder (Sure Sharp®).

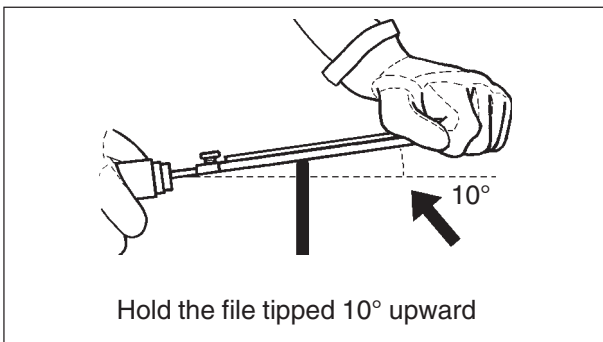

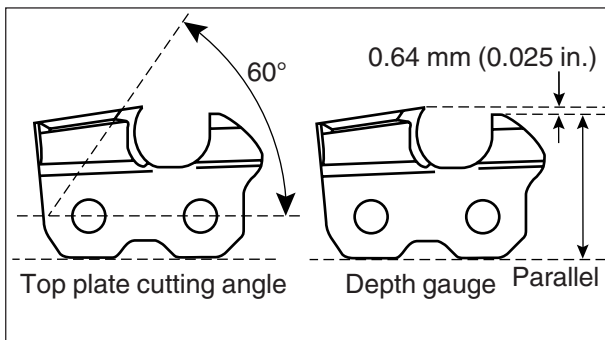
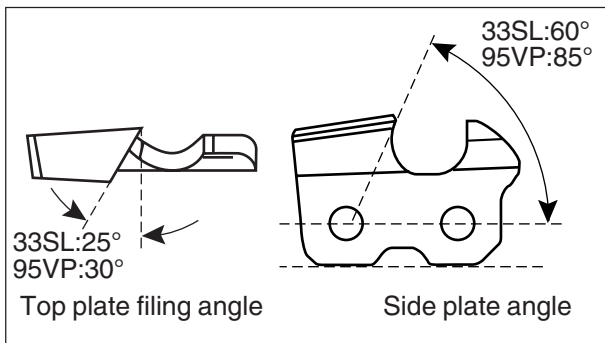
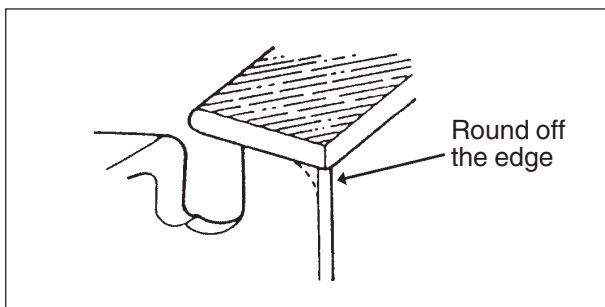
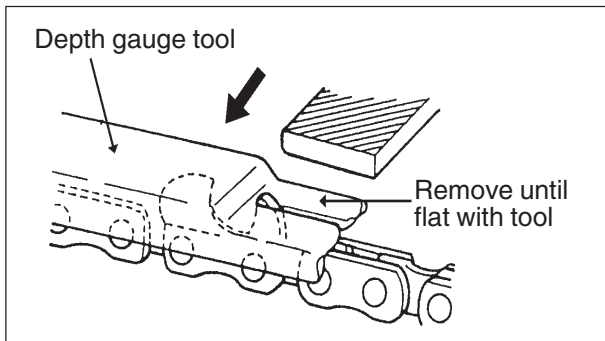
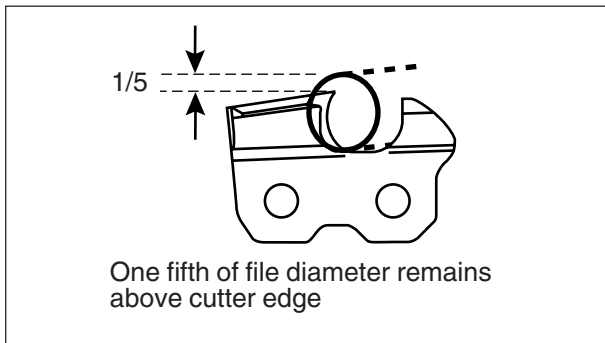

- Place the depth gauge tool firmly on guide bar so that depth gauge protrudes. Then file top of depth gauge with the flat file until flat with top of the depth gauge tool.

- Be sure to round off the front edge of the depth gauge.

Properly filed cutters are shown in illustration.

When setting of the chain is finished, soak it in oil and wash away filings completely before using.

- When chain has been filed on the bar, supply sufficient oil to it, rotate the chain slowly to wash away the filings before using again.
- If the chain saw is operated with filings clogged in the groove, the saw chain and the guide bar will be damaged prematurely.
- If the saw chain becomes soiled with resin, for instance, clean it with kerosene and soak in it oil.

NOTE

These angles are referred to as Oregon 33SL or 95VP. To sharpen other follow chain manufacturer's instruction.

TROUBLESHOOTING

Problem		Cause	Remedy
Engine	— hard to start — does not start		
Engine cranks →	Fuel at carburetor → No fuel at carburetor	<ul style="list-style-type: none"> • Fuel filter clogged • Fuel line clogged • Carburetor 	<ul style="list-style-type: none"> • Clean or replace • Clean • Ask your ECHO dealer
	Fuel at cylinder → No fuel at cylinder	<ul style="list-style-type: none"> • Carburetor 	<ul style="list-style-type: none"> • Ask your ECHO dealer
	↓ Muffler wet with fuel	<ul style="list-style-type: none"> • Fuel mixture is too rich 	<ul style="list-style-type: none"> • Open choke • Clean/replace air filter • Adjust carburetor • Ask your ECHO dealer
	Spark at end of plug wire → No spark at end of plug wire	<ul style="list-style-type: none"> • Ignition switch off • Electrical problem 	<ul style="list-style-type: none"> • Turn switch on • Ask your ECHO dealer
	↓ Spark at plug → No spark at plug	<ul style="list-style-type: none"> • Spark gap incorrect • Covered with carbon • Fouled with fuel • Spark plug defective 	<ul style="list-style-type: none"> • Adjust 0.6 mm to 0.7 mm (0.024 to 0.028 in.) • Clean or replace • Clean or replace • Replace plug
Engine does not crank		<ul style="list-style-type: none"> • Internal engine problem 	<ul style="list-style-type: none"> • Ask your ECHO dealer
Engine runs ↓	Dies or accelerates poorly ↓	<ul style="list-style-type: none"> • Air filter dirty • Fuel filter dirty • Fuel vent blocked • Spark plug • Carburetor • Cooling system blocked • Exhaust port/spark arrestor screen blocked 	<ul style="list-style-type: none"> • Clean or replace • Clean or replace • Clean • Clean and adjust/replace • Adjust • Clean • Clean

⚠ WARNING
Fuel vapors are extremely flammable and may cause fire and/or explosion. Never test for ignition spark by grounding spark plug near cylinder plug hole, otherwise serious personal injury may result.

STORAGE AFTER USE

- Inspect and adjust every part of the chain saw.
 - Completely clean every part and repair if necessary.
 - Apply thin coating of oil on metal parts to prevent rust.
- Remove chain and guide bar.
- Drain fuel tank, pull starter slowly a few times to drain fuel from carburetor.
- Pour a small amount of clean motor oil into spark plug hole, pull starter and crank the engine until piston reaches: TOP DEAD CENTER.
- Store in a dry area, free from dust.



WARNING

Do not store in an enclosure where fuel fumes may accumulate or reach an open flame or spark.



CAUTION

Do not lend or rent your chain saw without the Instruction manual and Safety manual.

NOTE

- For future reference, you should keep this Instruction manual and the Safety manual.
- If this Instruction manual or the Safety manual has become illegible or is lost, please purchase a new one from your ECHO dealer.

TECHNICAL DATA

			CS-520
Dimension	L × W × H	mm	398 × 252 × 272 (15.7 in. × 9.9 in. × 10.7 in.)
Mass	Power head, dry	kg	4.9 (10.8 lb.) Without chain and guide bar
Engine	Type		Air-cooled two-stroke single cylinder
	Displacement	mL (cm ³)	50.1 (3.057 cu. in.)
	Carburetor Magneto Spark plug Starter Power transmission		Diaphragm type Flywheel magneto: CDI system CHAMPION CJ-6Y or NGK BPM8Y Recoil starter Automatic centrifugal clutch
	Fuel	Mixture ratio	50 : 1 ratio with ECHO Power Blend™ two-stroke, air-cooled engine oil. 89 octane unleaded. Do not use fuel containing methyl alcohol, more than 10 % ethyl alcohol or 15 % MTBE.
	Tank capacity	L	0.60 (20.3 US. fl. oz.)
Oil	Bar and chain		ECHO bar and chain oil (or motor oil)
	Tank capacity	L	0.28 (9.5 US. fl. oz.)
Guide bar and saw chain			See page 22 for Chain and Guide Bar Combination
	Lubrication		Adjustable automatic oil pump
Engine speed	Idle	r/min	2300 - 3300
	Wide open throttle	r/min	11500 - 13000
Standard features			Front hand guard, Rear hand guard, Anti-vibration device, Spiked bumper, Throttle control lockout, Chain brake, Chain catcher, Spark arrestor muffler, Kick guard

* Technical data subject to change without notice.