



Power Blower

Operator's Manual

MODEL

PB-410

WARNING  **DANGER**



The muffler or catalytic muffler and surrounding cover may become extremely hot.

Always keep clear of exhaust and muffler area, otherwise serious personal injury may occur.



WARNING



The engine exhaust from this product contains chemicals known to the State of California to cause cancer, birth defects or other reproductive harm.



WARNING  **DANGER**

Read rules for safe operation and all instructions carefully. ECHO provides this Operator's Manual which must be read and understood for proper and safe operation.

INTRODUCTION

Welcome to the ECHO family. This ECHO product was designed and manufactured to provide long life and on-the-job-dependability. Read and understand this manual. You will find it easy to use and full of helpful operating tips and SAFETY messages.

WARNING DANGER

Read rules for safe operation and instructions carefully. ECHO provides this Operator's Manual which must be read and understood for proper and safe operation.

THE OPERATOR'S MANUAL

contains specifications and information for operation, starting, stopping, maintenance, storage and assembly specific to this product.

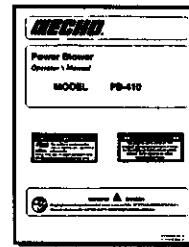

TABLE OF CONTENTS

Introduction	2	Maintenance	17
- The Operator's Manual	2	- Skill Levels	17
Manual Safety Symbols and Important Information ..	3	- Maintenance Intervals	17
Safety	3	- Air Filter	18
- Decals	3	- Fuel Filter	18
- International Symbols	4	- Spark Plug	19
- Equipment	4	- Cooling System	19
- Fuel	5	- Exhaust System	20
- Personal Condition and Safety Equipment	5	- Carburetor Adjustment	21
- Safe Operation	7	Troubleshooting	22
- Extended Operation/Extreme Conditions	8	Storage	23
Description	9		
- Emission Control	9		
- Contents	9		
Specifications	11		
Assembly	12		
- Install Blower Pipes	12		
- Install Stick Handle	12		
Pre-Operation	13		
- Fuel	13		
Operation	15		
- Starting Cold Engine	15		
- Starting Warm Engine	15		
- Stopping Engine	15		
- Operating Blower	16		

Specifications, descriptions and illustrative material in this literature are as accurate as known at the time of publication, but are subject to change without notice. Illustrations may include optional equipment and accessories, and may not include all standard equipment.

MANUAL SAFETY SYMBOLS AND IMPORTANT INFORMATION

Throughout this manual and on the product itself, you will find safety alerts and helpful, information messages preceded by symbols or key words. The following is an explanation of those symbols and key words and what they mean to you.



This symbol accompanied by the words **WARNING** and **DANGER** calls attention to an act or condition that can lead to serious personal injury to operator and bystanders.



The circle with the slash symbol means whatever is shown within the circle is prohibited.



IMPORTANT



NOTE

IMPORTANT The enclosed message provides information necessary for the protection of the unit.

NOTE This enclosed message provides tips for use, care and maintenance of the unit.

SAFETY

DECALS

Locate these safety decals on your unit. The complete unit illustration, found in the "DESCRIPTION" section, will help you locate them. Make sure the decals are legible and that you understand and follow the instructions on them. If a decal cannot be read, a new one can be ordered from your ECHO dealer.

HOTDECAL



-WARNING- -DANGER-



Read and follow all safety precautions in the operator's manual. Operators, helpers & bystanders can be severely injured by blown objects and must wear specified ANSI Z87.1 eye protection. Always wear hearing protection when operating.

-ADVERTENCIA -PELIGRO



Lea y obedezca todas las precauciones de seguridad que aparecen en el Manual del Operador. Los operadores, los asistentes y los espectadores pueden recibir lesiones graves debido a los objetos que se soplan y tienen que usar la protección para ojos ANSI Z87.1. Siempre use protección para los oídos cuando opere.



PB-410

MAXIMUM SOUND LEVEL **74dB(A)**
measured at 50 ft (15 m) per ANSI B175.2-1996

INTERNATIONAL SYMBOLS

Symbol form/shape	Symbol description/application	Symbol form/shape	Symbol description/application
	Read and understand Operator's Manual.		Fuel and oil mixture
	Wear eyes, ears and head protection		Finger Severing
	Hot Surface		Wear hand protection. Use two handed.
	Safety/Alert		Wear slip resistant foot wear.
	DO NOT allow flames or sparks near fuel.		DO NOT smoke near fuel.

Symbol form/shape	Symbol description/application	Symbol form/shape	Symbol description/application
	Engine choke control.		Ignition ON/OFF
	Emergency stop		Primer bulb
	Carburetor adjustment -Low speed mixture		Carburetor adjustment -High speed mixture
	Carburetor adjustment -Idle speed		

EQUIPMENT

Before operation a complete check of the unit must be performed:

- Check unit for loose/missing nuts, bolts and screws. Tighten and/or replace as needed.
- Inspect fuel lines, tank and area around carburetor for fuel leaks. **DO NOT** operate unit if leaks are found.

Spark Arrestor Muffler –

- The spark arrestor muffler controls the exhaust noise and prevents hot, glowing particles of carbon from leaving the muffler. Make sure the spark arrestor screen is in good repair and properly seated in the muffler. (Refer to Exhaust System Maintenance page 20.)

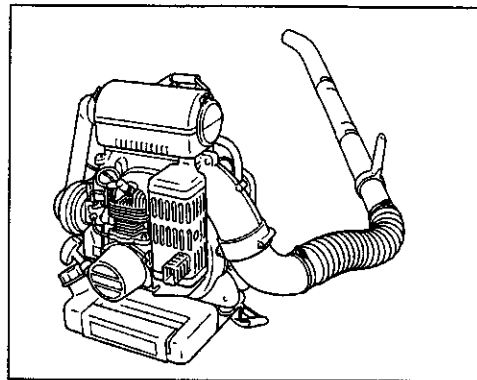

Parts –

- Do not use blower if any part is missing or damaged.
- Have repairs done only by an authorized ECHO Service dealer.
- Do not use any attachment, accessory or replacement part unless it is recommended in this Operator's Manual.



FUEL

WARNING  DANGER

Fuel is **VERY** flammable. Use extreme care when mixing, storing or handling or serious personal injury may result.

- Use an approved fuel container.
- **DO NOT** smoke near fuel.
- **DO NOT** allow flames or sparks near fuel.
- Fuel tanks/cans may be under pressure. Always loosen fuel caps slowly allowing pressure to equalize.
- **NEVER** refuel a unit when the engine is **HOT!**
- **NEVER** refuel a unit with the engine running.
- **DO NOT** fill fuel tanks indoors. **ALWAYS** fill fuel tanks outdoors over bare ground.
- Securely tighten fuel cap after refueling.
- Inspect for fuel leakage. If fuel leakage is found, do not start or operate unit until leakage is repaired.



IMPORTANT

Spilled fuel is a leading cause of hydrocarbon emissions. Some states may require the use of automatic fuel shut-off containers to reduce fuel spillage. Contact your ECHO dealer for ordering information.

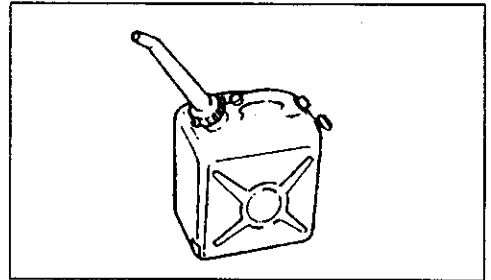

After Refueling:

- Wipe any spilled fuel from the unit.
- Move at least 3 m (10 ft.) from refueling location before starting.

After use:

- **DO NOT** store a unit with fuel in its tank. Leaks can occur. Return unused fuel to an approved fuel storage container.

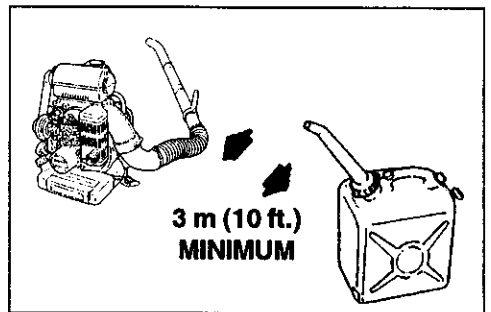

PERSONAL CONDITION AND SAFETY EQUIPMENT

WARNING  DANGER

Power Blower users risk injury to themselves and others if the Power Blower is used improperly and/or safety precautions are not followed. Proper clothing and safety gear must be worn when operating a Power Blower.

Physical Condition –

Your judgment and physical dexterity may not be good:

- if you are tired or sick,
- if you are taking medication,
- if you have taken alcohol or drugs.

Operate unit only if you are physically and mentally well.

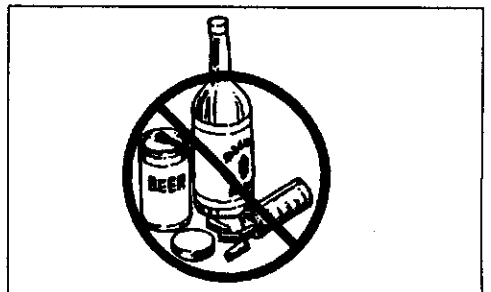

Eye Protection –

Wear eye protection that meets ANSI Z87.1 or CE requirements whenever you operate the blower.

**Hand Protection –**

Wear no-slip, heavy duty work gloves to improve your grip on the blower handle. Gloves also reduce the transmission of machine vibration to your hands.

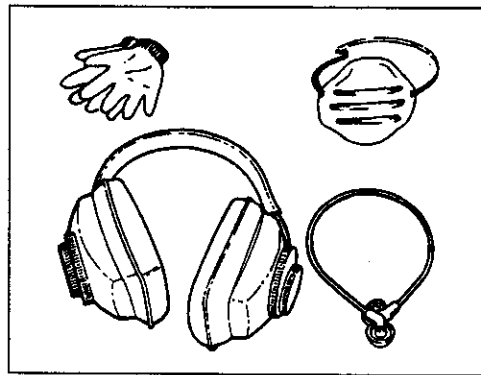
**Breathing Protection –**

Wear a face mask to protect against dust.

Hearing Protection –

ECHO recommends wearing hearing protection whenever unit is used.

Proper Clothing –

Wear snug fitting, durable clothing;

- Pants should have long legs, shirts with long sleeves.
- **DO NOT WEAR SHORTS,**
- **DO NOT WEAR TIES, SCARVES, JEWELRY.**

Wear sturdy work shoes with nonskid soles;

- **DO NOT WEAR OPEN TOED SHOES,**
- **DO NOT OPERATE UNIT BAREFOOTED.**

Keep long hair away from engine and blower intake. Retain hair with cap or net.

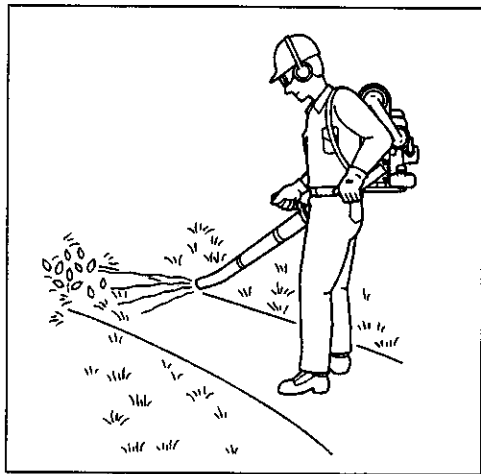
**Hot Humid Weather –**

Heavy protective clothing can increase operator fatigue which may lead to heat stroke. Schedule heavy work for early morning or late afternoon hours when temperatures are cooler.



SAFE OPERATION

Determine Operation Area –

- Do not operate this product indoors or in inadequately ventilated areas.
- Review area to be cleared. Look for potential hazards such as stones or metal objects.
- Spectators and fellow workers must be warned, and children and animals prevented from coming nearer than 15m (50 ft.) while the blower is in use.
- Take wind conditions into account: avoid open doors and windows.
- Provide all operators of this equipment with the Operator's Manual and instructions for safe operation.
- Do not point blower at people or animals.

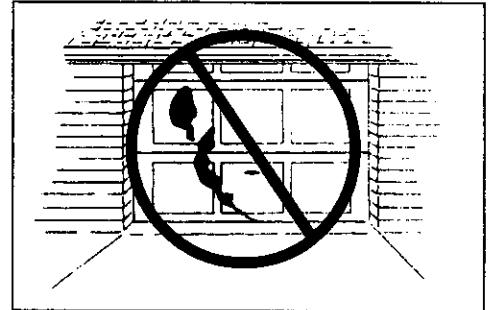

Use Proper Clothing & Equipment

- Before starting the unit, equip yourself and any other person working within the 15 m (50 ft.) Safety Zone with the required Protective Equipment and clothing.
- Keep long hair away from engine and blower intake. Retain hair with cap or net.
- Start unit on ground with throttle at idle. Check that blower pipe is not blocked by the ground or by any objects.

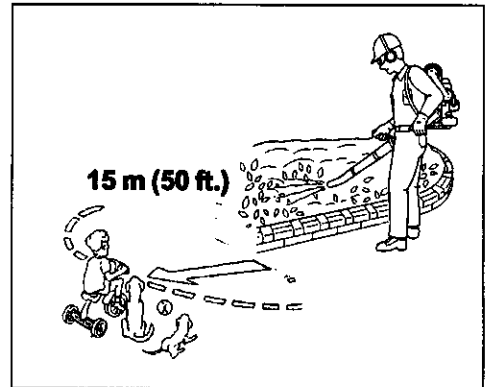

Keep A Solid Stance

- Maintain footing and balance at all times. Do not stand on slippery, uneven or unstable surfaces. Do not work in odd positions or on ladders.
- Do not perform Maintenance or Assembly procedures with engine running.

Noise Control

- Follow local noise regulations on sound levels and hours of operations. Use only during appropriate hours.
- Never use a higher speed setting than necessary to perform a task. The higher the engine speed the louder the blower noise.
- Be a good neighbor.



Avoid Hot Surfaces

- During operation, the muffler and surrounding cover may become extremely hot. Avoid contact during and immediately after operation. Always keep exhaust area clear of flammable debris. Allow the engine and muffler to completely cool before performing any maintenance activity.

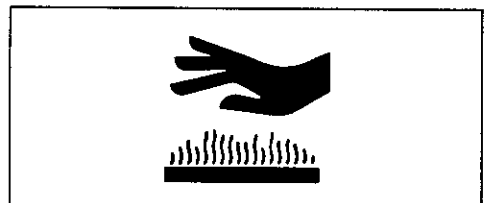

EXTENDED OPERATION / EXTREME CONDITIONS

Vibration and Cold –

It is believed that a condition called Raynaud's Phenomenon, which affects the fingers of certain individuals may be brought about by exposure to vibration and cold. Exposure to vibration and cold may cause tingling and burning sensations followed by loss of color and numbness in the fingers. The following precautions are strongly recommended because the minimum exposure which might trigger the ailment is unknown.

- Keep your body warm, especially the head, neck, feet, ankles, hands and wrists.
- Maintain good blood circulation by performing vigorous arm exercises during frequent work breaks and also by not smoking.
- Limit the hours of operation. Try to fill each day with jobs where operating the blower or other hand-held power equipment is not required.
- If you experience discomfort, redness and swelling of the fingers followed by whitening and loss of feeling, consult your physician before further exposing yourself to cold and vibration.

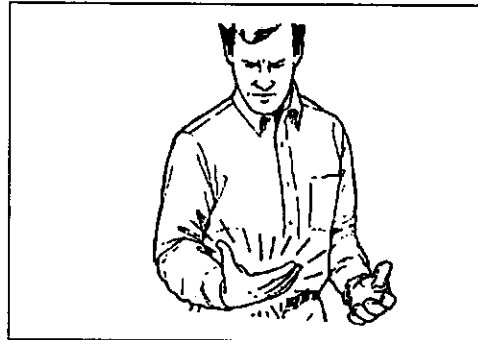
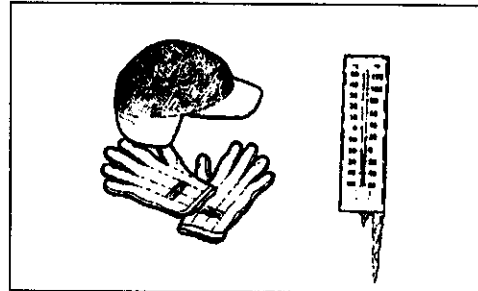

Repetitive Stress Injuries –

It is believed that overusing the muscles and tendons of the fingers, hands, arms and shoulders may cause soreness, swelling, numbness, weakness and extreme pain in those areas. Certain repetitive hand activities may put you at a high risk for developing a Repetitive Stress Injury (RSI). An extreme RSI condition is Carpal Tunnel Syndrome (CTS), which could occur when your wrist swells and squeezes a vital nerve that runs through the area. Some believe that prolonged exposure to vibration may contribute to CTS. CTS can cause severe pain for months or even years. To reduce the risk of RSI/CTS, do the following:

- Avoid using your wrist in a bent, extended or twisted position. Instead try to maintain a straight wrist position. Also, when grasping, use your whole hand, not just the thumb and index finger.
- Take periodic breaks to minimize repetition and rest your hands.
- Reduce the speed & force in which you do the repetitive movement.
- Do exercises to strengthen the hand and arm muscles.
- Immediately stop using all power equipment and consult a doctor if you feel tingling, numbness or pain in the fingers, hands, wrists or arms. The sooner RSI/CTS is diagnosed, the more likely permanent nerve and muscle damage can be prevented.

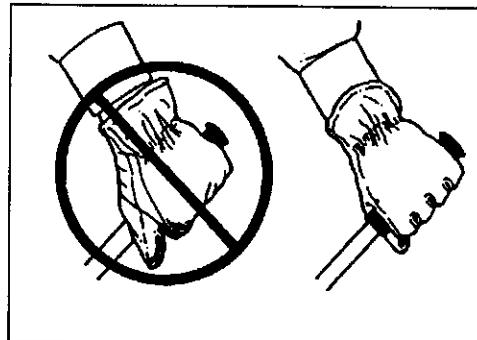

DESCRIPTION

EMISSION CONTROL

EPA Phase II

The emission control system for these engines are EM (Engine Modification).

IMPORTANT ENGINE INFORMATION

ENGINE FAMILY: 2EHXS, 04D4RA DISPLACEMENT: 39,7cc
EMISSION COMPLIANCE PERIOD: 300Hours
THIS ENGINE MEETS U.S. EPA PH2 EMISSION REGULATIONS
FOR SMALL NONROAD ENGINE. REFER TO OWNER'S MANUAL
FOR MAINTENANCE SPECIFICATIONS AND ADJUSTMENTS.



ECHO CORP. *##

An Emission Control Label is located on the engine. (This is an EXAMPLE ONLY, information on label varies by engine FAMILY).

PRODUCT EMISSION DURABILITY

The 300 hour emission durability period is the time span selected by the manufacturer certifying the engine emissions output meets applicable California emissions regulations, provided that approved maintenance procedures are followed as listed in the Maintenance Section of this manual.

CONTENTS

- 1 - Power Head
- 1 - Blower Pipe Assembly
- 1 - Operator's Manual
- 1 - Warranty Registration Card
- 1 - ECHO Emissions and Warranty Statement
- 1 - Bottle ECHO 2-Stroke Oil Mix

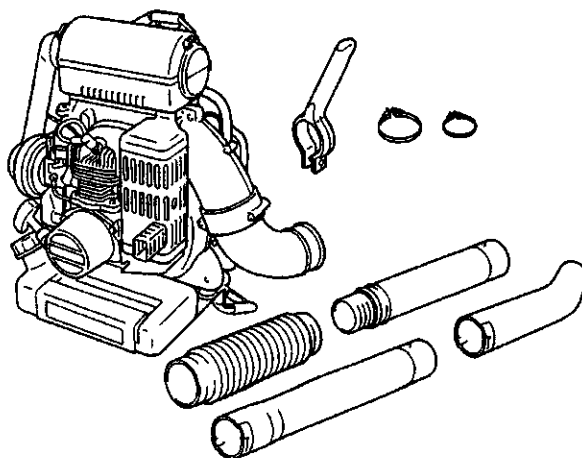
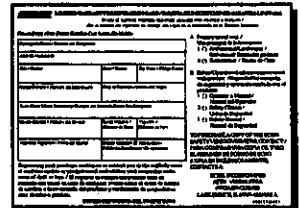
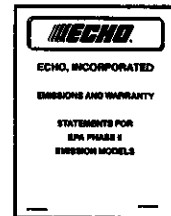
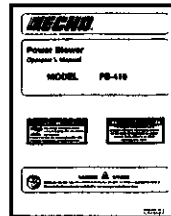

10 ECHO®

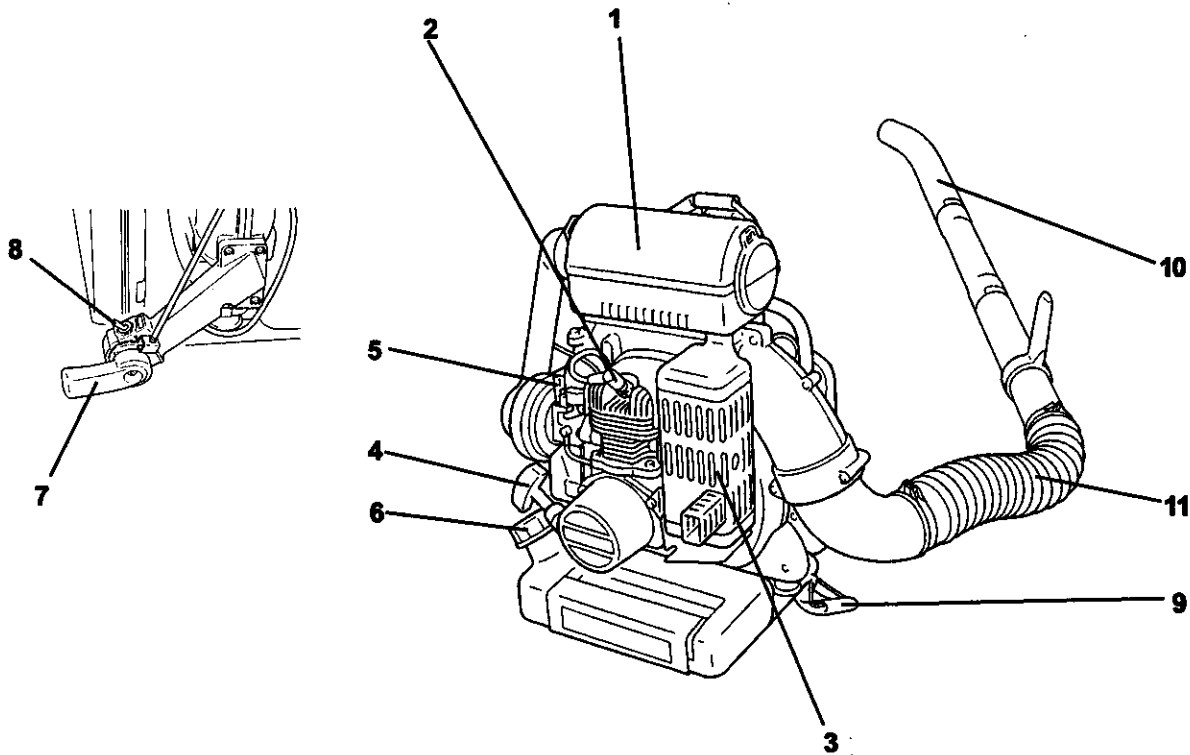

1. **AIRCLEANER**- Contains replaceable air filter element.
2. **SPARK PLUG**- Provides spark to ignite fuel mixture.
3. **MUFFLER/SPARK ARRESTOR**-The spark arrestor muffler controls the exhaust noise while the spark arrestor prevents hot, glowing particles of carbon from leaving the muffler.
4. **RECOIL STARTER HANDLE**- Pull recoil handle slowly until starter engages, then return handle slowly. **DO NOT** let handle snap back or damage to unit will occur.
5. **CHOKE LEVER**- Push lever **DOWN** to close choke (starting position) and for emergency stopping. Lift **UP** to open choke (run position).
6. **FUEL TANK CAP**- For closing the fuel tank.
7. **THROTTLE LEVER**- Controls engine speed.
8. **STOP SWITCH**- "Toggle Switch"
9. **SHOULDER HARNESS**- Used to support unit on operator's back. The straps are adjustable.
10. **BLOWER PIPES**-
11. **FLEXIBLE PIPE**- Allows for full range of movement.

SPECIFICATIONS

MODEL	PB-410
Length	330 mm (13.0 in.) (w/o pipes)
Width	440 mm (17.3 in.)
Height	440 mm (17.3 in.)
Mass (dry)	9.7 kg (21.4 lb.) (w/o pipes)
Engine Type	Air cooled, two-stroke, single cylinder gasoline engine
Displacement	39.7 mL (2.42 cu. in.)
Bore	38.0 mm (1.50 in.)
Stroke	35.0 mm (1.38 in.)
Carburetor	Walbro Diaphragm, model WT-410C
Ignition System	Flywheel Magneto, capacitor discharge ignition type
Spark Plug	NGK BPM-8Y Gap 0.65 mm (0.026 in.)
Exhaust System	Spark Arrestor Muffler
Fuel	Mixed (Gasoline and Two-stroke Oil)
Fuel/Oil Ratio	50:1 ECHO High Performance, two-stroke air cooled engine oil
Gasoline	89 Octane unleaded. DO NOT use fuel containing methyl alcohol. Gasoline may contain 15% MTBE (methyl tertiary-butyl ether).
Oil	50:1 ECHO High Performance, two-stroke air cooled engine oil
Fuel Tank Capacity	1.5 L (50.7 US fl. oz.)
Recoil Starter System	Automatic Recoil Starter Centrifugal Type
Wide Open Throttle Speed (r/min)	7000 - 7600
Idle Speed (r/min)	2200 - 3000
Maximum Air Volume	10.6 m ³ /min. (375 cu. ft./min.)
Maximum Air Speed w/pipes (m/s)	78 (175 mph)
Sound Level at 50 ft. dB(A) scale per ANSIB175.2	74 dB(A)

ASSEMBLY

WARNING DANGER

Never perform maintenance or assembly procedures with engine running or serious personal injury may result.

INSTALL BLOWER PIPES

1. Assemble throttle lever bracket to the fan case using four screws.
- Set stop lead into the recess of bracket.
2. Assemble the flexible pipe thru elbow to the blower and tighten clamp.
3. Assemble the flexible pipe and the straight pipe w/swivel and tighten the clamp.
4. Assemble straight section of the pipe to the other end of the pipe.
5. Assemble the curved pipe and rotate the desired angle.
6. Shoulder harness is adjustable to fit any operator.
7. Adjust the length of strap for easier operation.

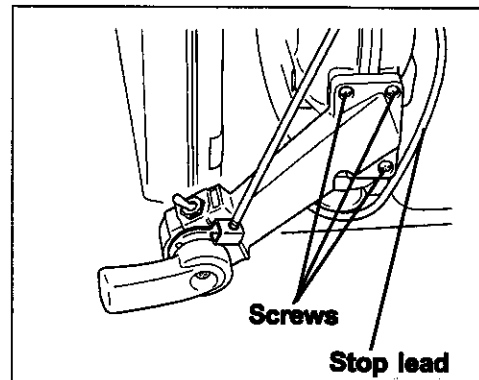
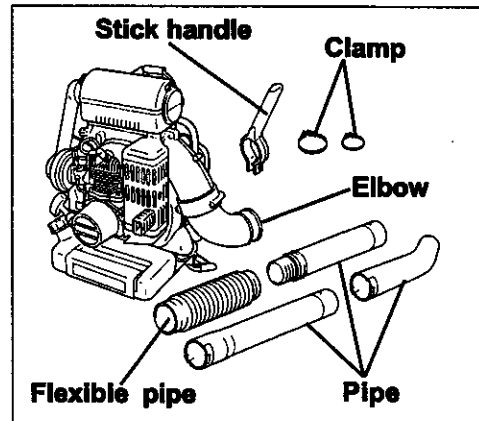

INSTALL STICK HANDLE

1. Remove blower pipe from swivel tube.
2. Loosen wing nut completely and expand open stick handle clamp.
3. Align notches in handle clamp with pipe pegs. Handle should be angled away from operator.
4. Slide handle onto swivel tube.
5. Position handle for comfortable operation and tighten wing nut.
6. Install blower pipe to swivel tube.

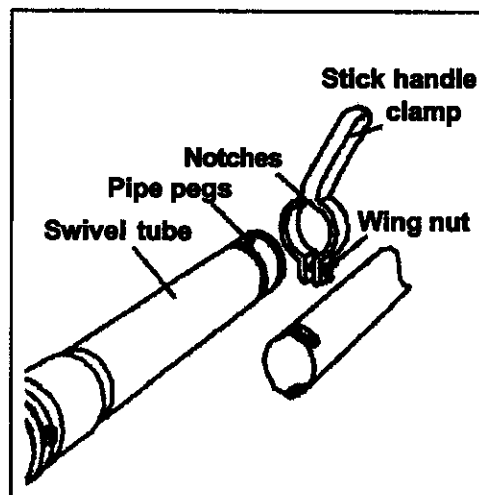

PRE-OPERATION

FUEL

Fuel Requirements

Gasoline - Use 89 Octane [$R_{\frac{1}{2}}^{\pm M}$] (mid grade or higher) gasoline known to be good quality. Gasoline may contain 15% MTBE (methyl tertiary-butyl ether).

Gasohol containing methyl (wood) alcohol is **NOT** approved.

Two Stroke Oil - A two-stroke engine oil meeting ISO-L-EGD (ISO/CD 13738) and J.A.S.O. **FC** Standards, must be used. ECHO brand Premium 50:1 oil meets this standard. Engine problems due to inadequate lubrication caused by failure to use an ISO-L-EGD and J.A.S.O. **FC** certified oil, such as ECHO Premium 50:1 Two-stroke Oil, will void the two-stroke engine warranty. (Emission related parts only are covered for two years, regardless of two-stroke oil used, per the statement listed in the California Emission Defect Warranty Explanation.)

IMPORTANT

ECHO Premium 2-stroke oil may be used at 50:1 ratio in an engine that was ever made and sold by ECHO regardless of the ratio specified in the older operator manuals.

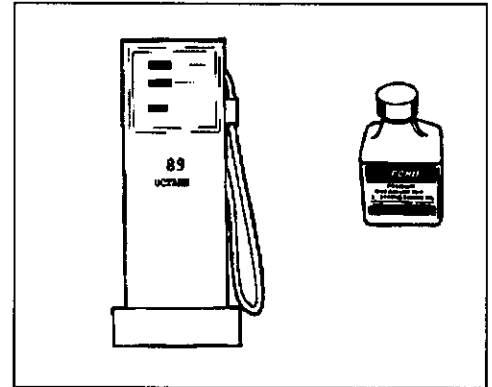

Mixing-

1. Fill an approved fuel container with half of the required amount of gasoline.
2. Add 2stroke oil to gasoline.
3. Close container and shake to mix oil with gasoline.
4. Add remaining gasoline and remix.
5. Install fuel container cap and wipe spilled fuel from container and surrounding area.

Handling Fuel

WARNING **DANGER**

Fuel is **VERY** flammable. Use extreme care when mixing, storing or handling or serious personal injury may result.

- Use an approved fuel container.
- **DO NOT** smoke near fuel.
- **DO NOT** allow flames or sparks near fuel.
- Fuel tanks/cans may be under pressure. Always loosen fuel caps slowly allowing pressure to equalize.
- **NEVER** refuel a unit when the engine is **HOT!**
- **NEVER** refuel a unit with the engine running.
- **DO NOT** fill fuel tanks indoors. **ALWAYS** fill fuel tanks outdoors over bare ground.
- Securely tighten fuel cap after refueling.
- Inspect for fuel leakage. If fuel leakage is found, do not start or operate unit until leakage is repaired.



IMPORTANT

Spilled fuel is a leading cause of hydrocarbon emissions. Some states may require the use of automatic fuel shut-off containers to reduce fuel spillage. Contact your ECHO dealer for ordering information.

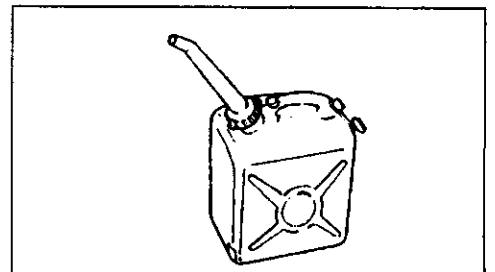

14 ECHO®

After Refueling -

- Wipe any spilled fuel from the unit.
- Move at least 3 m (10 ft.) from refueling location before starting.

After use -

- DO NOT store a unit with fuel in its tank. Leaks can occur. Return unused fuel to an approved fuel storage container.

Storage -

Fuel storage laws vary by locality. Contact your local government for the laws affecting your area. As a precaution, store fuel in an approved, air tight container. Store in a well ventilated, unoccupied building, away from sparks and flames. Do not store fuel longer than 30 days.

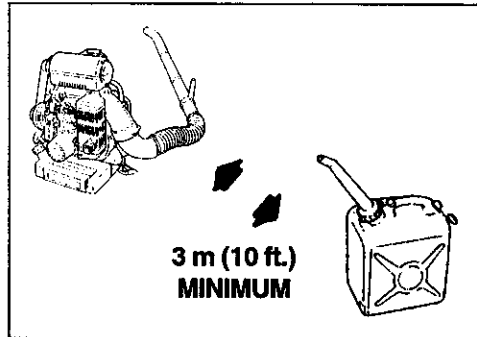

IMPORTANT

Stored fuel ages. Do not mix more fuel than you expect to use in thirty (30) days, ninety (90) days when a fuel stabilizer is added.

Stored two-stroke fuel may separate. ALWAYS shake fuel container thoroughly before each use.

S	M	T	W	T	F	S
1	2	3	4	5	6	7
8	9	10	11	12	13	14
15	16	17	18	19	20	21
22	23	24	25	26	27	28
29	30	31				

OPERATION

- Provide all operators of this equipment with the Operator's Manual and instructions for safe operation.
- Check unit for loose nuts, bolts and screws daily.
- Recoil starter: Use short pulls - only 1/2 - 2/3 of rope length for starting. Do not allow the rope to snap back in. Always hold the unit firmly.
- Rotate spring loaded throttle handle downward to a comfortable operating position.

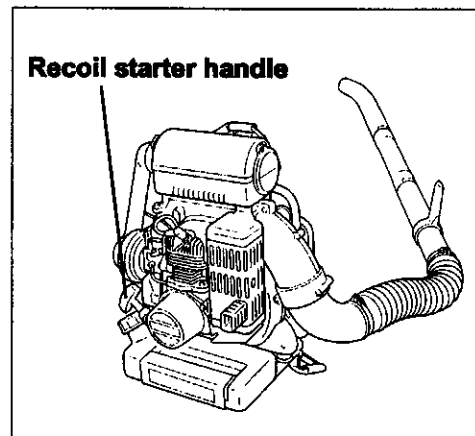

STARTING COLD ENGINE

1. Turn switch to "RUN" position.
2. Close choke (move choke lever down) and pull recoil starter handle until engine fires.
3. Open choke and if necessary, restart engine.

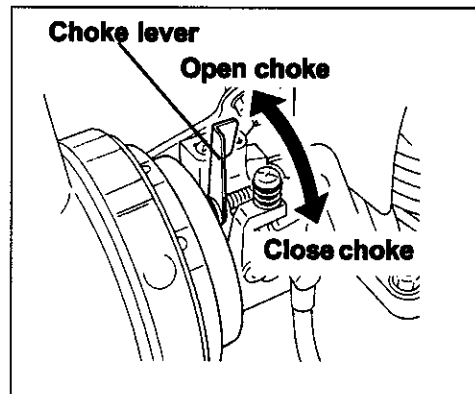

NOTE

Allow engine to warm up before use.

STARTING WARM ENGINE

1. Turn switch to "RUN" position.
2. Move throttle lever to start/idle position, pull recoil starter handle 5 times and engine should start. Do not use choke.

NOTE

If engine does not start after 4 pulls, use cold start procedures.

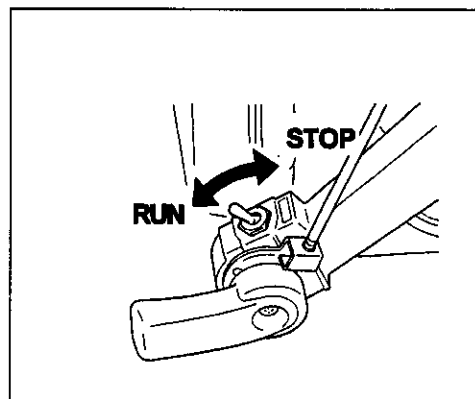

STOPPING ENGINE

1. Move throttle lever to idle position and allow engine to run at idle for a few minutes.
2. Move switch to "STOP" position.

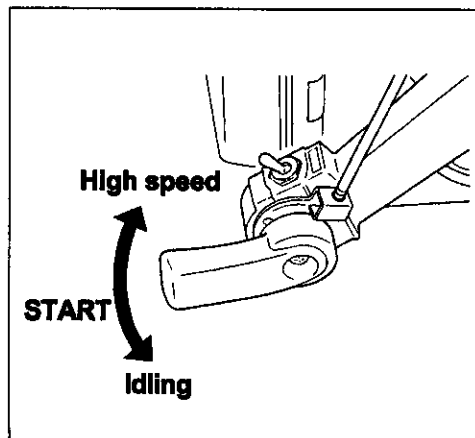

WARNING DANGER

If engine does not stop, move choke lever to closed position to stall engine. Check and repair stop switch before starting engine again or serious personal injury may result.

OPERATING BLOWER

WARNING DANGER

Always wear safety glasses, hearing protection, a face filter mask and take all safety precautions or serious personal injury may result.

Do not point the blower pipe in the direction of people or pets.

Read the Safety Section carefully.

IMPORTANT

To avoid engine damage due to over revving, do not block blower pipe opening.

1. Use only during appropriate hours.
2. Make sure bevel at end of pipe faces downward.
3. Allow the engine to warm up at a fast idle for a few minutes.
4. Set engine speed.
5. Use lower speed to blow dry leaves from a lawn or flower bed.
6. Additional speed may be necessary to clean grass and leaves from walks, patios and drives.
7. Higher speed may be necessary to move gravel, dirt, snow, bottles or cans from a driveway, street, parking lot or stadium.

NOTE

Never use a higher speed setting than necessary to perform a task. Remember, the higher the engine speed, the louder the blower noise. Minimize dust by using blower at lower speeds when necessary. Keep debris on your property. Be Smart - be a good neighbor.

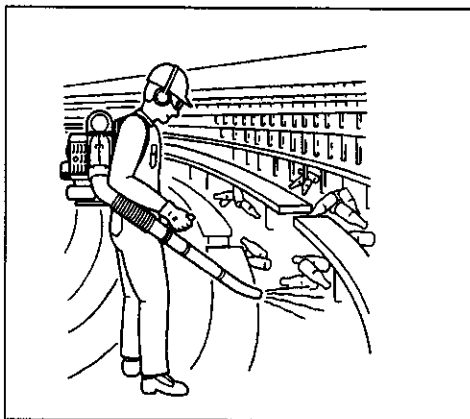
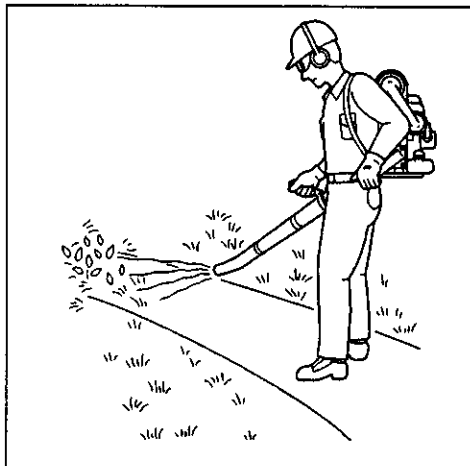
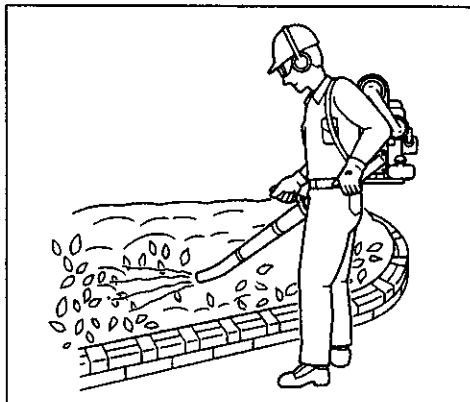

Be Smart!
With Power Equipment

MAINTENANCE

Your ECHO blower is designed to provide many hours of trouble free service. Regular scheduled maintenance will help your blower achieve that goal. If you are unsure or are not equipped with the necessary tools, you may want to take your unit to an ECHO Service Dealer for maintenance. To help you decide whether you want to DO-IT-YOURSELF or have the ECHO Dealer do it, each maintenance task has been graded. If task is not listed, see your ECHO Dealer for repairs.

SKILL LEVEL

- Level 1**= Easy to do. Most required tools come with unit.
- Level 2**= Moderate difficulty. Some specialized tools may be required.
- Level 3**= Experience required. Specialized tools are required. Echo recommends the unit be returned to your Echo Dealer for servicing.

ECHO offers **REPOWER™** Maintenance Kits and Parts to make your maintenance job easier. Just below each task heading are listed the various part numbers required for that task. See your ECHO dealer for these parts.

MAINTENANCE INTERVALS

COMPONENT/ SYSTEM	MAINTENANCE PROCEDURE	REQ'D SKILL LEVEL	DAILY OR BEFORE USE	EVERY REFUEL	3 MONTHS OR 90 HOURS	6 MONTHS OR 270 HOURS	YEARLY
Recommended Echo Dealer Maintenance Procedures							
Cylinder Exhaust Port	Inspect/Clean/Decarbon	3			I / C		
Do-It-Yourself Maintenance Procedures							
Air Filter	Inspect/Clean/Replace	1	I / C		R*		
Choke	Inspect/Clean	2	I / C				
Fuel Filter	Inspect/Replace	1			I		R*
Fuel System, Leaks	Inspect/Replace	1	I	I / R*			
Cooling System	Inspect/Clean	2	I / C				
Muffler Spark Arrestor	Inspect/Replace	2			I / R*		
Recoil Starter Rope	Inspect/Clean	1	I / C				I / R*
Spark Plug	Inspect/Clean	2			I / C	R*	
Screws/Nuts/Bolts	Inspect/Tighten/Replace	1	I / R*				

MAINTENANCE PROCEDURE LETTER CODES: I = INSPECT, R = REPLACE, C = CLEAN

IMPORTANT NOTE - Time intervals shown are maximum. Actual use and your experience will determine the frequency of required maintenance.

MAINTENANCE PROCEDURE NOTES:

* All recommendations to replace are based on the finding of damage or wear during inspection.

AIR FILTER

Level 1.

NOTE

Clean daily.

1. Close choke (Cold Start Position). This prevents dirt from entering the carburetor throat when the air filter is removed. Brush accumulated dirt from the air cleaner area.
2. To take out a air filter, loosen both clamps of air cleaner and remove filter cover as shown.
3. Clean and inspect the element for damage. If element is fuel soaked and very dirty, replace it.
4. If element can be cleaned and reused, be certain it:
 - still fits the cavity in the air cleaner cover.
 - is installed with the original side out.

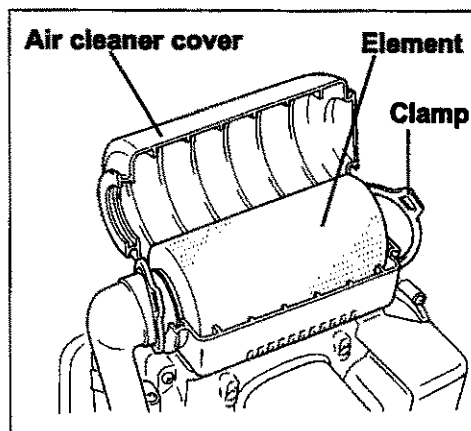

FUEL FILTER

Level 1.

WARNING  **DANGER**

Fuel is **VERY** flammable. Use extreme care when mixing, storing or handling.

1. Use a clean rag to remove loose dirt from around fuel cap and empty fuel tank.
2. Use the "fuel line hook" to pull the fuel line and filter from the tank.
3. Remove the filter from the line and install the new filter.

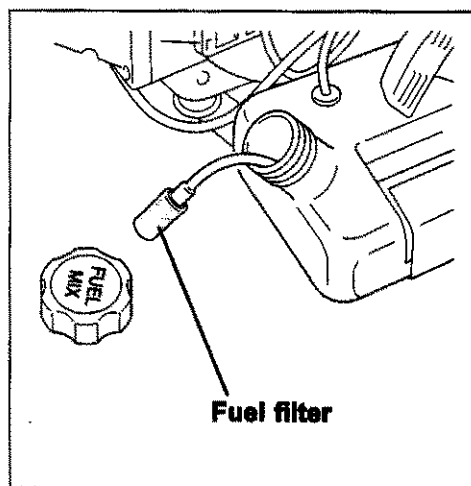

WARNING  **DANGER**

Muffler operates at extremely high temperatures. Muffler area must be kept clean. Do not perform maintenance on the engine or muffler until engine and muffler are completely cool, otherwise serious personal injury may occur.

SPARK PLUG

Level 2.

1. Remove spark plug and check for fouling, worn and rounded center electrode.
2. Clean the plug or replace with a new one. DO NOT sand blast to clean. Remaining sand will damage engine.
3. Adjust spark plug gap by bending outer electrode.
4. Tighten spark plug to 15 - 17 N·m (130 - 145 in. lb.).

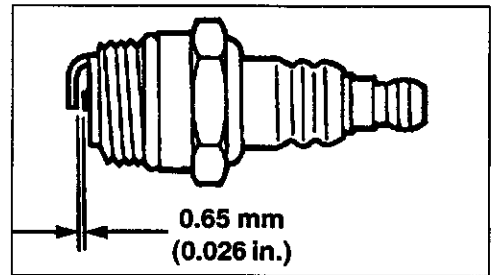

COOLING SYSTEM

Level 2.

IMPORTANT

To maintain proper engine operating temperatures, cooling air must pass freely through the cylinder fin area. This flow of air carries combustion heat away from the engine.

Overheating and engine seizure can occur when:

- Air intakes are blocked, preventing cooling air from reaching the cylinder.
- Dust and grass build up on the outside of the cylinder. This build up insulates the engine and prevents the heat from leaving.

Removal of cooling passage blockages or cleaning of cooling fins is considered "Normal Maintenance". Any failure attributed to lack of maintenance is not warranted.

Cleaning Grill

- Brush accumulated debris from intake grill.

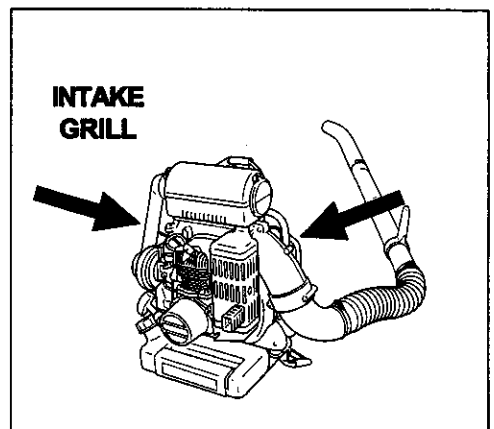

Cleaning Cylinder Fins

- Check periodically.
 - Clogged fins result in poor engine cooling.
 - Clean the passage of air between the cylinder fins to let cooling air pass easily.

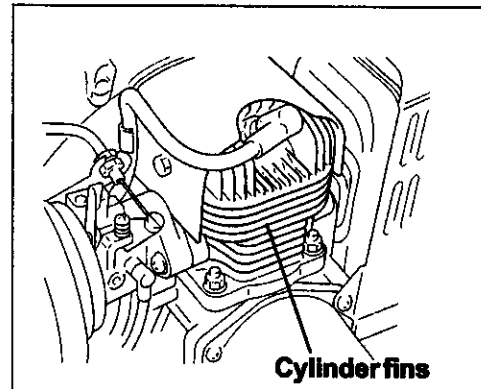

EXHAUST SYSTEM

Spark Arrestor Screen

Level 2.

IMPORTANT

Carbon deposits in muffler will cause a drop in engine output and overheating. Spark arrestor screen must be checked periodically.

1. Remove spark arrestor cover, gaskets and spark arrestor screen from muffler. Replace screen if plugged with carbon deposits.
2. Install spark arrestor screen, gaskets, and cover.
3. Tighten all screws securely.

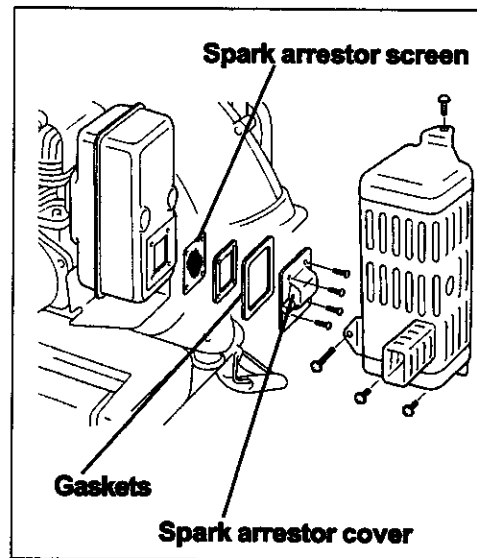

Cylinder Exhaust Port

Level 3.

IMPORTANT

The cylinder exhaust port must be inspected and cleaned of excess carbon every 3 months or 90 hours of operation in order to maintain this engine within the emissions durability period. ECHO strongly recommends that you return your unit to your ECHO dealer for this important maintenance service.

- In the event that the engine should lose power and overheat, the muffler should be removed and checked for excessive deposits.
- Carbon build up in the exhaust port should be removed with a piece of wood, ensuring that particles of carbon are not allowed to enter the cylinder.
- Remove all carbon deposits from the muffler flange area and wash the complete unit in a suitable solvent.

CARBURETOR ADJUSTMENT

Engine Break-In

New engines must be operated a minimum duration of two tanks of fuel break-in before carburetor adjustments can be made. During the break-in period your engine performance will increase and exhaust emissions will stabilize. Idle speed can be adjusted as required.

High Altitude Adjustment

High altitude adjustment is not required for proper operation of this engine.

Level 2.

NOTE

Every unit is run at the factory and the carburetor is set in compliance with California Emission Regulations. In addition, the carburetor is equipped with "H" (High Speed Needle) and "L" (Low Speed Needle) needle adjustment limiters that prevent settings outside acceptable limits.

1. Before adjusting carburetor clean or replace air filter and muffler, "Spark Arrestor Screen".
2. Start engine and run several minutes to bring to operating temperature. Flash choke twice during warm-up to clear any air from the fuel system.
3. Stop engine. Turn "H" speed needle CCW (Counter Clockwise) to stop. Turn "L" speed needle midway between full CW (Clockwise) stop and CCW stop.
4. Idle Speed Adjustment
 - Before adjusting blower, install all blower pipes. Start engine, turn "idle" speed adjustment screw either CW or CCW until the tip just contacts the throttle plate. Then turn (2) two additional turns CW for initial setting. Blower should operate with an even idle at low r/min.
5. Accelerate to full throttle for 2 - 3 seconds to clear any excess fuel in the engine, then return to idle. Accelerate engine to full throttle to check for smooth transition from idle to high speed. If engine hesitates turn "L" needle CCW 1/8 turn and repeat acceleration. Continue adjustment until smooth acceleration results.
6. Check idle speed and reset if necessary as described in item 4.

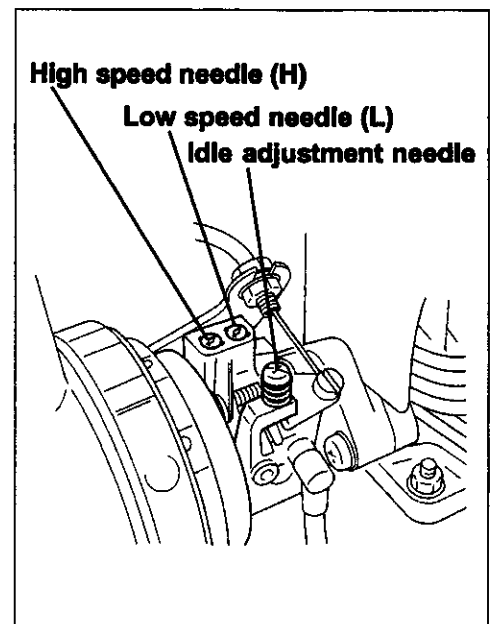

TROUBLESHOOTING

Problem		Cause	Remedy
Engine - starts hard			
Engine - does not start			
Engine Cranks	Fuel at carburetor	No fuel at carburetor	Fuel strainer clogged Fuel line clogged Carburetor
	Fuel at cylinder	No fuel at cylinder	Carburetor
		Muffler wet with fuel	Fuel Mixture is too rich
	Spark at end of plug wire	No spark at end of plug wire	Stop switch off Electrical problem
	Spark at plug	No spark at plug	Spark gap incorrect Covered with carbon Fouled with fuel Spark plug defective
Engine does not crank		Internal engine problem	Ask your ECHO dealer
Engine runs	Dies or accelerates poorly	Air filter dirty Fuel filter dirty Fuel vent plugged Spark plug Carburetor Cooling system plugged Spark arrestor screen plugged	Clean or replace Replace Replace Clean and adjust/replace Adjust Clean Clean
Engine runs properly	Blower does not work, is weak or uneven.	Blower pipe clogged, loose, or damaged.	Unclog Tighten

WARNING DANGER

Fuel vapors are **extremely** flammable and may cause fire and/or explosion. **Never** test for ignition spark by grounding spark plug against cylinder, otherwise serious personal injury may result.

STORAGE

WARNING DANGER

During operation, the muffler and surrounding cover becomes hot. Always keep exhaust area clear of flammable debris during transportation or when storing, otherwise serious property damage or personal injury may result.

Long Term Storage (Over 30 Days)

Do not store your unit for a prolonged period of time (30 days or longer) without performing protective storage maintenance which includes the following:

1. Store unit in a dry, dust free place, out of the reach of children.

WARNING DANGER

Do not store where fuel fumes may accumulate or reach an open flame or spark.

2. Place the stop switch in the "STOP" position.
3. Remove accumulation of grease, oil, dirt and debris from exterior of unit.
4. Perform all periodic lubrication and services that are required.
5. Tighten all screws and nuts.
6. **Drain** the fuel tank **completely** and pull the recoil starter handle several times to remove fuel from the carburetor.
7. Remove the spark plug and pour 7 mL (1/4 oz., 1/2 tablespoon) of fresh, clean ECHO 2-stroke engine oil into the cylinder through the spark plug hole.
 - A. Place a clean cloth over the spark plug hole.
 - B. Pull the recoil starter handle 2 or 3 times to distribute the oil inside the engine.
 - C. Observe the piston location through the spark plug hole. Pull the recoil handle slowly until the piston reaches the top of its travel and leave it there.
8. Install the spark plug (do not connect ignition cable).
9. Remove blower pipe assembly from unit.

