



OPERATOR'S MANUAL

**ECHO
CHAIN SAW
CS-510EVL
CS-510EVL P**

CAUTION

Read Rules for Safe Operation
and Instructions Carefully



RULES FOR SAFE OPERATION

A. Kickback Safety Precaution for Chain Saw Users

WARNING!

KICKBACK may occur when the nose or tip of the guide bar touches an object, or when the wood closes in and pinches the saw chain in the cut.

Tip contact in some cases may cause a lightning fast reverse REACTION, Kicking the guide bar up and back towards the operator. pinching the saw chain along the top of the guide bar may push the guide bar rapidly back towards the operator. Either of these reactions may cause you to lose control of the saw which could result in serious personal injury.

Do not rely exclusively upon the safety devices built into your saw. As a chain saw user, you should take several steps to keep your cutting jobs free from accident or injury.

1. With a basic understanding of kickback, you can reduce or eliminate the element of surprise. Sudden surprise contributes to accidents.

2. Keep a good firm grip on the saw with both hands, the right hand on the rear handle, and the left hand on the front handle, when the engine is running. Use a firm grip with thumbs and fingers encircling the chain saw handles. A firm grip will help you reduce kickback and maintain control of the saw. Don't let go.
3. Make sure that the area in which you are cutting is free from obstructions. Do not let the nose of the guide bar contact a log, branch, or any other obstruction which could be hit while you are operating the saw.
4. Cut at high engine speeds.
5. Do not overreach or cut above shoulder height.
6. Follow manufacturer's sharpening and maintenance instructions for the saw chain.
7. Only use replacement bars and chains specified by the manufacturer or the equivalent.

B. Other Safe Precautions

1. Do not operate a chain saw when you are fatigued.
2. Use safety footwear; snug-fitting clothing; protective gloves; and eye, hearing, and head protection devices.
3. Use caution when handling fuel. Move the chain saw at least 10 feet (3 m) from the fueling point before starting the engine.
4. Do not allow other persons to be near the chain saw when starting or cutting with the chain saw. Keep bystanders and animals out of the work area.
5. Do not start cutting until you have a clear work area, secure footing, and a planned retreat path from the falling tree.

6. Keep all parts of your body away from the saw chain when the engine is running.
7. Before you start the engine, make sure that the saw chain is not contacting anything.
8. Carry the chain saw with the engine stopped, the guide bar and saw chain to the rear, and the muffler away from your body.
9. Do not operate a chain saw that is damaged, improperly adjusted, or not completely and securely assembled. Be sure that the saw chain stops moving when the throttle control trigger is released.
10. Shut off the engine before setting the chain saw down.
11. Use extreme caution when cutting small size brush and saplings because slender material may catch the saw chain and be whipped toward you or pull you off balance.
12. When cutting a limb that is under tension, be alert for springback so that you will not be struck when the tension in the wood fibers is released.
13. Keep the handles dry, clean, and free of oil or fuel mixture.
14. Operate the chain saw only in well-ventilated areas.
15. Do not operate a chain saw in a tree unless you have been specifically trained to do so.
16. All chain saw service, other than the items listed in the operator's manual maintenance instructions, should be performed by competent chain saw service personnel. (For example, if improper tools are used to remove the flywheel or if an improper tool is used to hold the flywheel in order to remove the clutch, structural damage to the flywheel could occur and could subsequently cause the flywheel to burst.)
17. When transporting your chain saw, use the appropriate guide bar scabbard.
18. Spark arrester mufflers approved to SAE Standard J335b are Standard on ECHO Chain saws to reduce the possibility of forest fires. Do not operate the chain saw with a loose or defective muffler. Do not remove the spark arrester screen.

CONTENTS

	Page
RULES FOR SAFE OPERATION	1
TECHNICAL DATA	4
NOMENCLATURE OF PARTS	4
PREPARATION FOR USE	5
– FRONT HANDLE AND HAND GUARD INSTALLATION	5
– SPIKE BUMPER	6
– GUIDE BAR AND SAW CHAIN	6
– FUEL AND LUBRICANT	7
STARTING AND STOPPING	8
– STARTING	8
– STOPPING	9
CUTTING INSTRUCTION	10
– GENERAL	10
– FELLING A TREE	11
– LIMBING	11
– BUCKING	12
MAINTENANCE AND CARE	14
– CARBURETOR	14
– AIR FILTER	14
– FUEL STRAINER	14
– GUIDE BAR	14
– SPROCKET	15
– AUTOMATIC OILER	15
– SPARK PLUG	15
– CYLINDER FINS	15
SETTING THE SAW CHAIN	16
TROUBLE SHOOTING	19
STORAGE AFTER USE	20
CHAIN BRAKE (Model CS-510EVLP only)	21

TECHNICAL DATA

Dimension:	L x W x H (mm)	400 x 255 x 280 (15.8" x 10.0" x 11.0")					
Weight:	Power Head, dry (kg)	5.9 (w/o chain and guide bar): (13.0 lbs)					
Engine:	Type Displacement (cc) Carburetor Magneto Spark plug Starter Power transmission	Air cooled 2-stroke single cylinder 49.9 (3.0 cu.in.) Walbro diaphragm type HDA Flywheel magneto, CDI (Capacitor Discharge Ignition System) CHAMPION CJ-6Y Recoil starter Automatic centrifugal clutch					
Fuel:	Mixture ratio Tank capacity (l)	Mixture of regular grade gasoline and air cooled two stroke engine oil [32:1 Ratio or 50:1 Ratio with special oil approved by ECHO] 0.50 (16.9 FL.OZ.US)					
Chain oil:	Chain oil Tank capacity (l)	Motor oil 0.25 (8.5 FL.OZ.US)					
Guide bar and saw chain:	Supplied separately not in carton	Guide bar		Chain			
		Asymmetrical-Low Kick Type		Low Kick-Guard Link Type			
		Length	Part No.		Pitch	Part No.	Links
		18"	ECHO 16A50	OREGON 7929	3/8"	OREGON 76SL	60
		16"	16D50	30591	3/8"	76SL	60
*20"	20A50	7930	3/8"	76SL	70		
20"	20D50	30590	3/8"	76SL	70		
24"	24A50	7931	3/8"	76SL	81		
		* Standard Configuration					
Lubrication		Automatic plunger type pump, adjustable					
Standard features:		Hand guards, Front and rear Lockout, Throttle control Mountings, Anti-vibration Latch, High speed idle Chain catcher Chain brake.....Model CS-510EVLP Only					

NOMENCLATURE OF PARTS

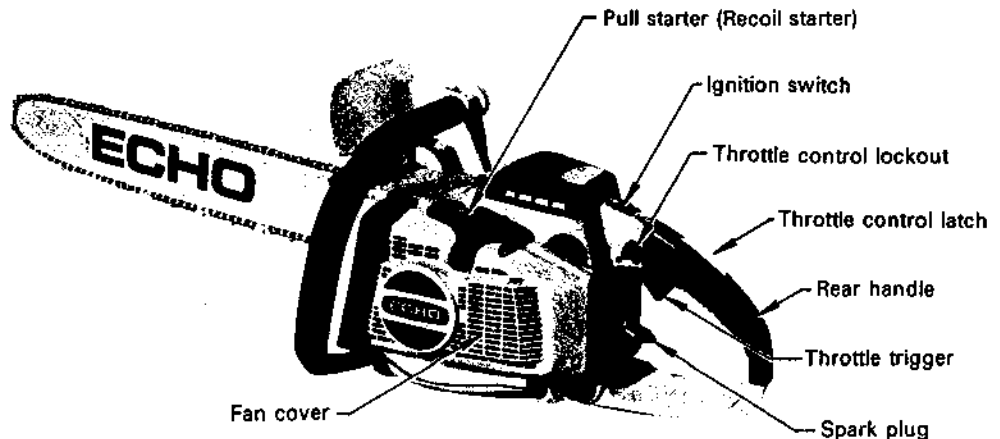
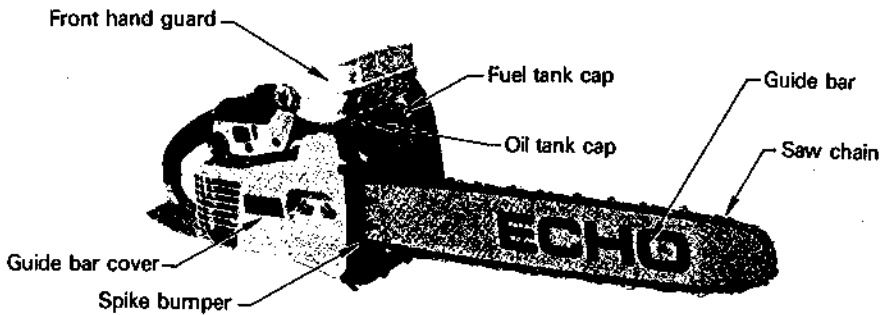

FRONT HANDLE and HAND GUARD INSTALLATION

Install the front handle and hand guard before installing the guide bar and saw chain, in numerical order as shown.

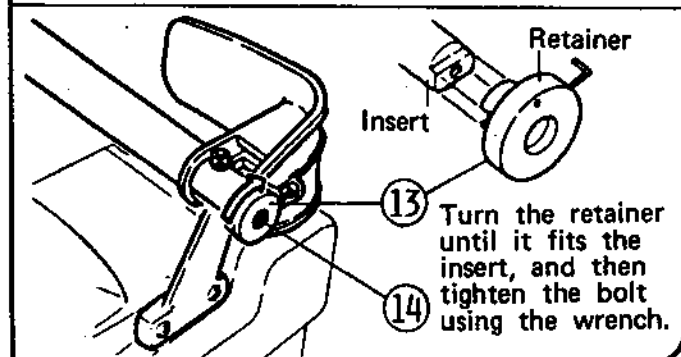
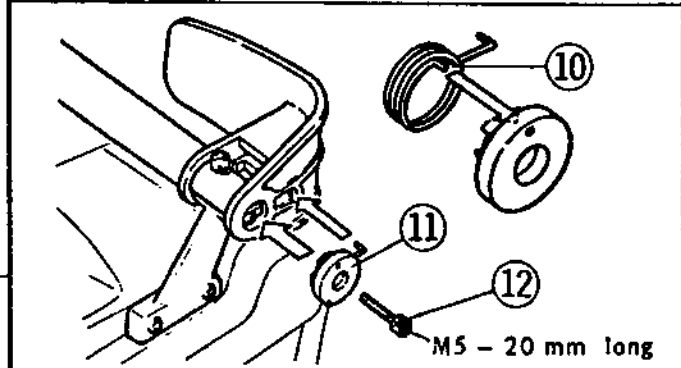
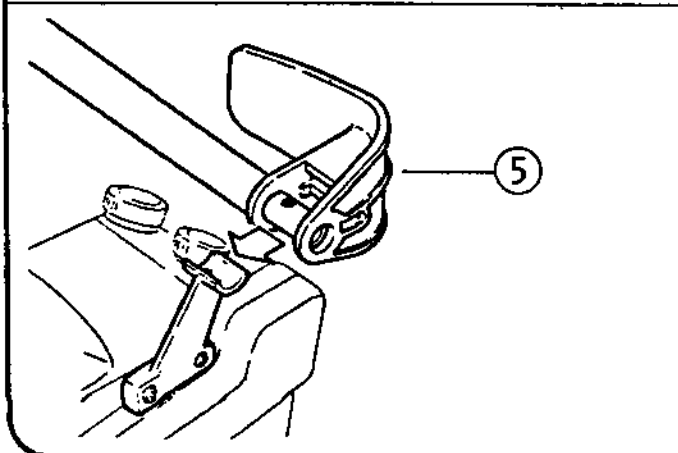
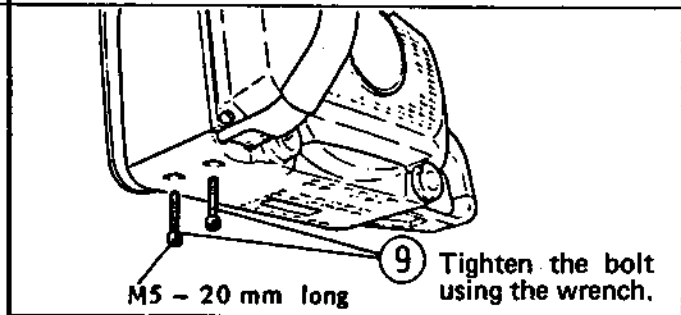
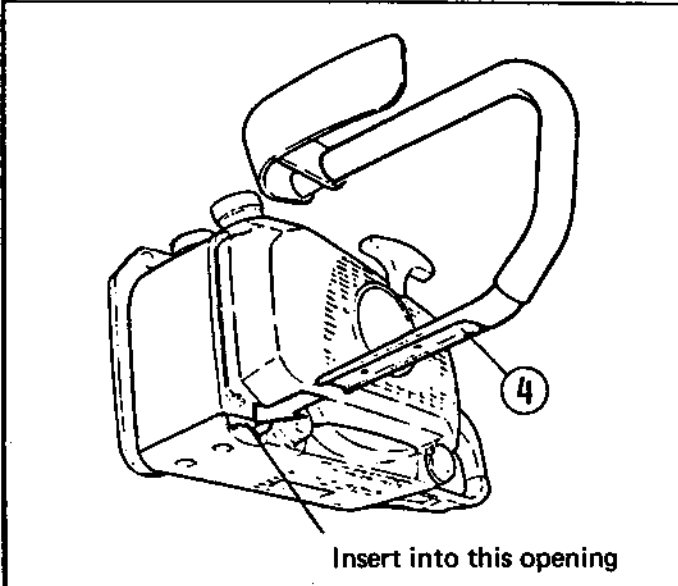
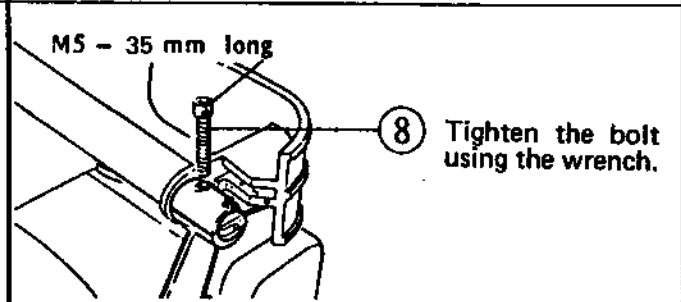
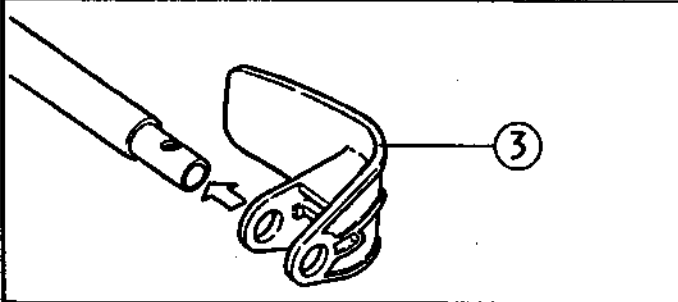
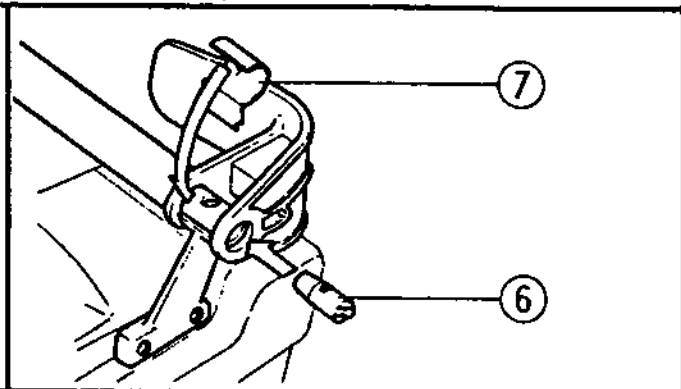
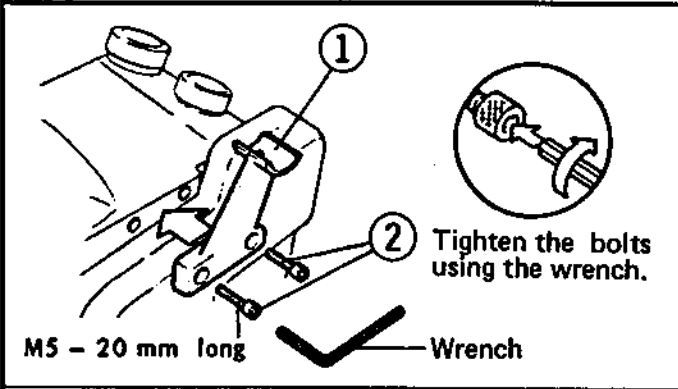

SPIKE BUMPER

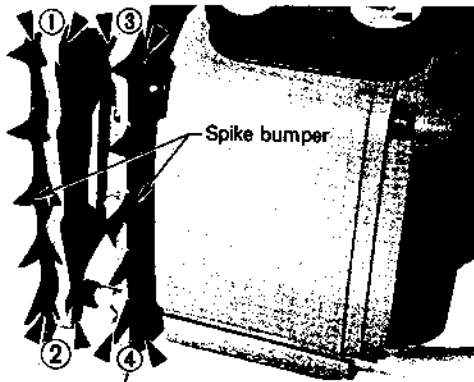

- Install the both spikes on the front of power head and guide bar cover as shown. (Use four bolts and nuts.)

GUIDE BAR AND SAW CHAIN

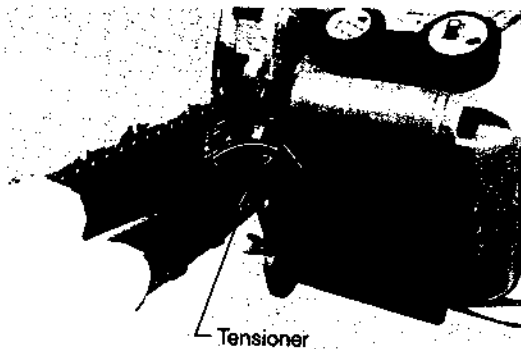
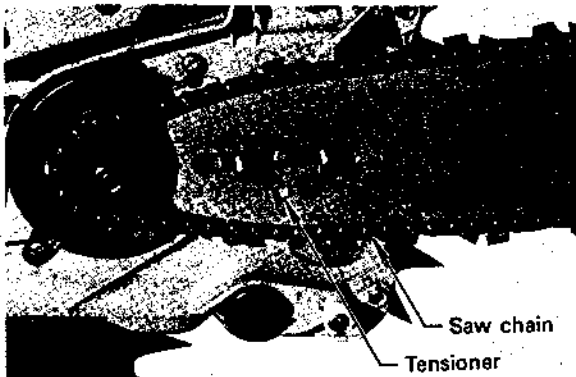
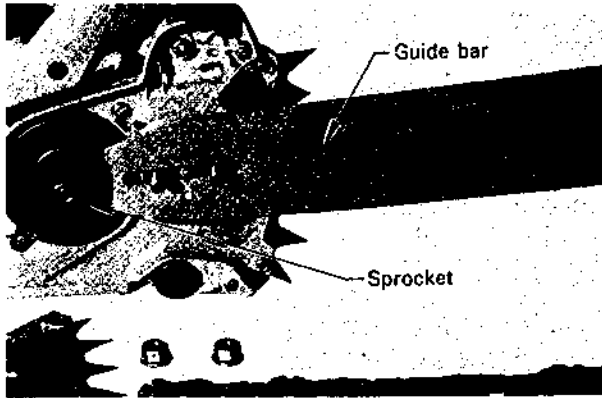

MOUNTING THE GUIDE BAR AND CHAIN (see illustration)

- Remove the guide bar cover and outer side plate, leaving the inner side plate in position.
- Mount the guide bar ensuring that the chain tensioner fits in the hole provided.
- Holding the bar in this position, feed the chain around the sprocket and into the guide bar groove.
- Fit the outer side plate, guide bar cover and nuts. Secure the nuts hand tight.

NOTES

1. The inner side plate is fitted with a narrow lubricating oil slot at the top.
2. The guide bar must be installed with the smaller nose radius at the top.
3. Ensure that the chain is installed with the cutters directed forward on the top of the bar.

WARNING

KICKBACK IS DANGEROUS. The low kick asymmetrical bar must be mounted with the reduced radius section of the nose on top as illustrated. Incorrect installation may result in serious or fatal injury.

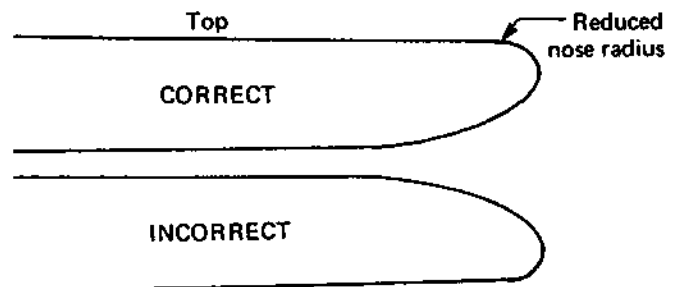

ADJUSTMENT, CHAIN TENSION

- Turn the adjuster screw clockwise until the chain touches the bottom of the bar.
- Hold the bar nose up and tighten the chain until there is no clearance between the bar and chain tie straps.
- Tighten both nuts with the bar nose held up to eliminate clearance.
- Pull the chain around the bar by hand. Loosen the adjustment if you feel tight spots.
- Start the engine and run at low speed. Stop and readjust if necessary.

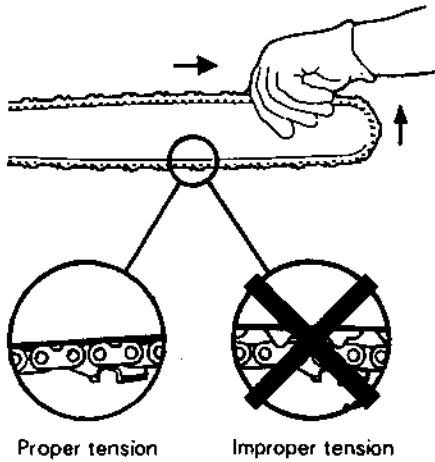

CAUTION

1. All adjustments should be made cold.
2. Always wear gloves when working on chain.
3. Do not operate with a loose chain

FUEL AND LUBRICANT

- Fuel is a mixture of regular grade gasoline and the ECHO brand motor oil (or an air cooled 2-cycle engine oil of a reputable brand name).

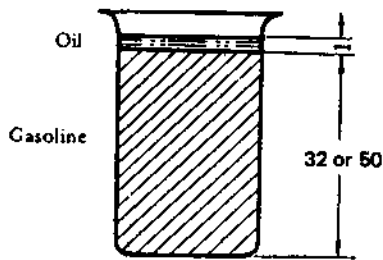

- Mixture ratio is Gasoline 32 parts: Oil 1 part.

- Fuel mixture at a ratio other than 32:1 may cause malfunction of the engine. Watch out for mixture ratio.

[NOTE]

50:1 Ratio is applicable with special oil approved by ECHO.

- Pour 1/2 the gasoline into the safe container, add the oil and mix thoroughly. Now add the remainder of gasoline and mix again.
- Disregard instruction on oil container.
- Do not use motor oil other than that recommended above.
- Do not mix directly in engine fuel tank.
- Avoid spilling fuel or oil. Spilled fuel should always be wiped up.

Normal Use

Leaded Fuel, Regular Grade

Alternate or Emergency Use

Unleaded Fuels—Min. Octane 87 ($\frac{M}{2}$)
Do not Use Gasohol

- Fuel Mix Chart

32 : 1			
(US)		(METRIC)	
GAS	OIL	GAS	OIL
Gal.	Fl.oz.	Liter	cc.
1	4.0	4	125
2	8.0	8	250
5	20.0	20	625

50 : 1			
(US)		(METRIC)	
GAS	OIL	GAS	OIL
Gal.	Fl.oz.	Liter	cc.
1	2.6	4	80
2	5.1	8	160
5	12.8	20	400

- Chain Lubricant

Proper lubrication of the chain while in operation reduces friction to the minimum between the chain and the guide bar, and assure a longer service life. Use motor oil of proper quality for this purpose.

- Do not use waste or reclaimed oil to avoid various oiler problems.
- Use motor oil of the following grades:
 - SAE NO. 30 in summer
 - SAE NO. 10 in winter or when cutting resinous trees
- When refilling fuel mixture, fill up chain oil at the same time.

STARTING AND STOPPING

Check for loose nuts and screws on the handle, fan cover, etc., each time before using the chain saw.

STARTING

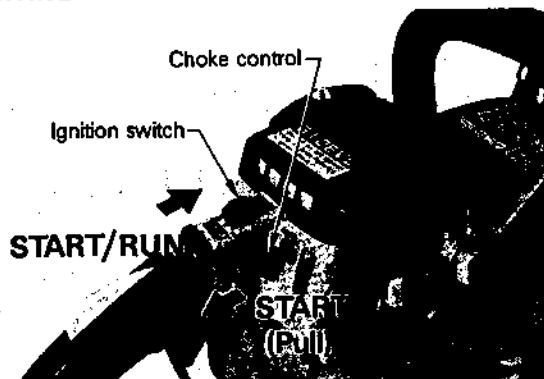

WHEN THE ENGINE IS COLD

- Fill the fuel tank with fuel mixture.
- Fill the chain oil tank with lubricant.
- Slide ignition switch to front.
- Pull choke fully.



- Securely hold the saw as shown and pull starter handle several times until first firing sound.
- Make sure bar and chain are in the clear while starting the saw.

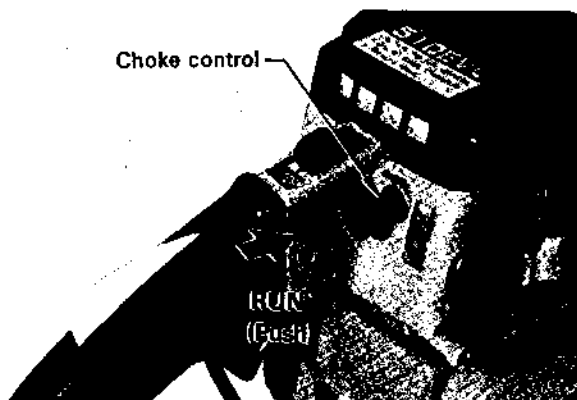

- Push choke in totally.
- Pull starter handle again.

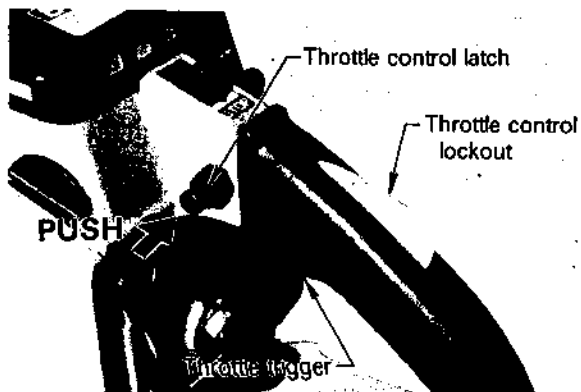

WHEN THE ENGINE IS HARD TO START

- Press lock down while grasping throttle trigger and push in latch as shown.
- Pull starter handle.
- When engine starts, immediately pull throttle trigger up, to release the latch.

CAUTION

Clutch engages and chain will rotate when engine is started with throttle latch engaged. After engine starts, release throttle trigger to idle engine.

Never use the latch for cutting.

Use it only when starting the engine.

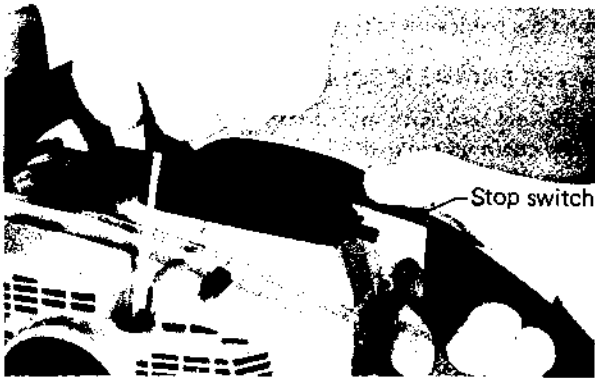

WHEN THE ENGINE IS WARM

- Confirm fuel and chain oil in the tanks.
- Slide ignition switch to front.
- Pull starter handle.
- Choke may be used if necessary but be sure to push it back on first firing sound.



**CONFIRM PROPER
LUBRICATION OF SAW
CHAIN AND BAR**

RUNNING

- When engine starts, keep idling for a few minutes.
- Pull throttle trigger gradually and increase revolution of the engine.
- The chain starts running when the engine reaches to 3,000 rpm.
- Confirm proper acceleration and lubrication of chain and bar.
- Do not run the engine at high speed unnecessarily.

STOPPING

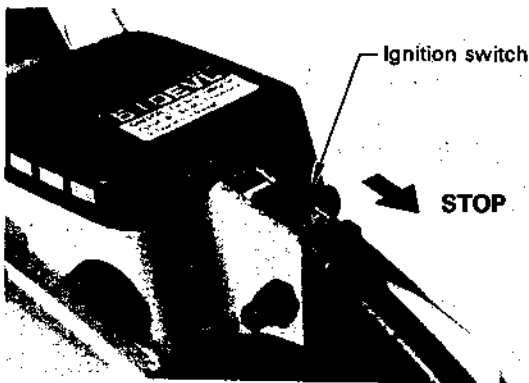

- Release throttle trigger and slide ignition switch back.

[NOTE]

When engine does not stop, pull choke fully to stop engine.

Check and repair ignition switch before starting the engine again.

CUTTING INSTRUCTION

GENERAL

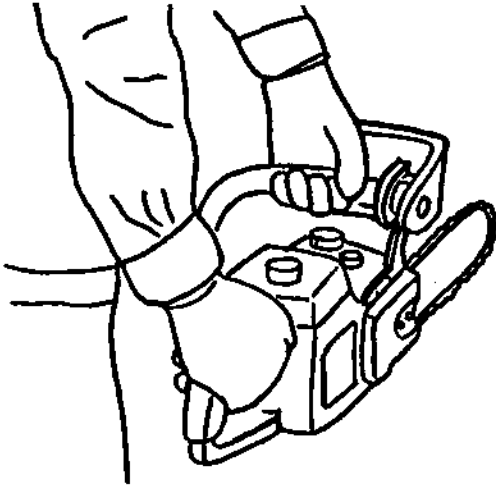

In all circumstances the operation of the chain saw is a one-man job. It is difficult at times to take care for your own safety, so don't assume the responsibility for a helper as well. After you have learned the basic techniques of using the saw, your best aid will be your own good common sense . . .

The accepted way to hold the saw is to stand to the left of the saw with your left hand on the front handlebar and your right hand on the rear handle so you can operate the throttle trigger with your right index finger.

Before attempting to fell a tree, cut some small logs or limbs. Become thoroughly familiar with the controls and the responses of the saw.

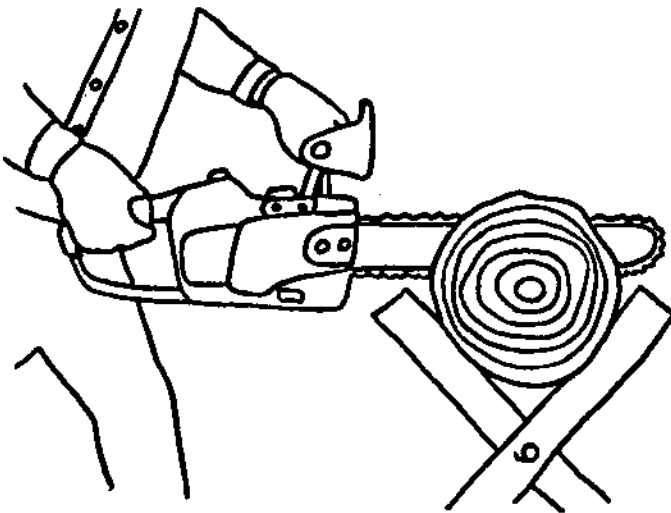

Start the engine, see that it is running properly. Squeeze the trigger to open the throttle wide open and start the cut. If the chain is properly sharpened, the cutting should be relatively effortless. It is not necessary to press down hard to make the saw cut. Pushing the saw too hard will slow the engine and cutting will actually be more difficult.

Some material may adversely affect the housings of your Echo chain saw.

(Example palm Tree Acid, fertilizer etc.) To avoid housing deterioration, carefully remove all packed saw dust around clutch and guide bar area and wash with water."

CAUTION

Do not let the tip of the bar touch anything while the engine is running. At cutting speed the chain is moving, at a high rate of speed. Should the tip contact a limb or log while the chain is moving, the tip will be pushed upward with considerable force. This is known as kick-back. Avoid it!

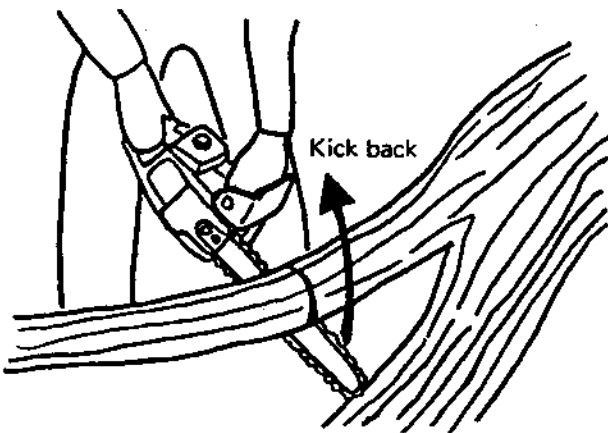

CAUTION

Wear suitable hearing protective device such as earmuffs or earplugs to protect against objectionable or uncomfortable loud noises.

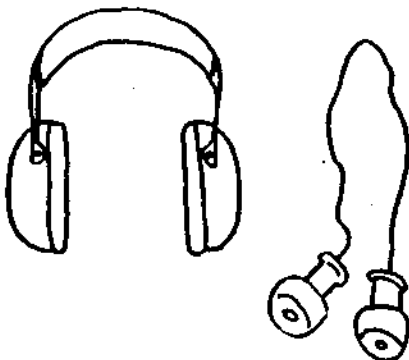

FELLING A TREE

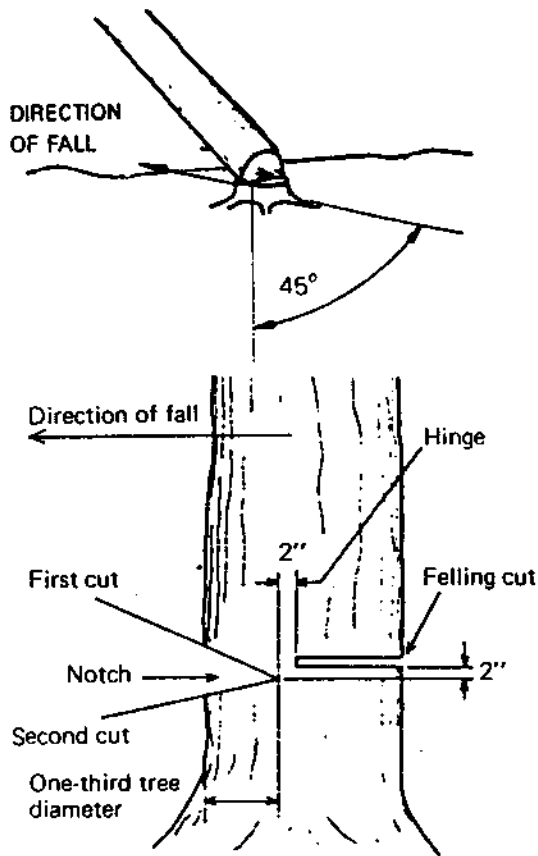

A falling tree can seriously damage anything it may hit – a car, a house, a fence, a powerline, or another tree. There are ways to make a tree fall where you want it, so first decide where that is!

Before cutting, clear the area around the tree. You will need good footing while working and you should be able to work the saw without hitting any obstacles. Next, select a path of retreat. When the tree begins to fall you should retreat away from the direction of fall at a 45 degree angle to avoid the trunk kicking back over the stump.

Begin the cut on the side to which the tree is to fall. Cut a notch about 1/3 of the way into the tree as shown. The position of this notch is important since the tree will try to fall "into" the notch. The felling out is made on the side opposite the notch and at a level about 2" above the bottom of the notch. Do not try to cut through to the notch with the felling cut. The remaining wood between the notch cut and felling cut (about 2") will act as a hinge when the tree falls, guiding it in the desired direction. When the tree starts to fall, kill the engine, place the saw on the ground and make your retreat quickly.

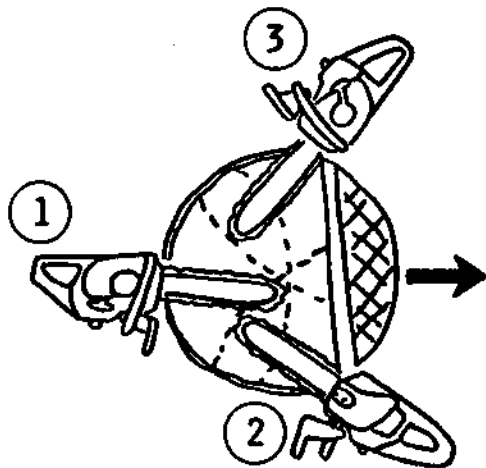

To fell big trees with a diameter exceeding twice the bar length, start the notching cuts from one side and draw the saw through to the other side of the notch. Start the back cut on one side of the tree, pivoting the saw through to form the desired hinge on that side.

Then remove the saw for the second cut. Insert the saw in the first cut, very carefully so as not to cause kickback. The final cut is made by drawing the saw forward in the cut to reach the hinge.

LIMBING

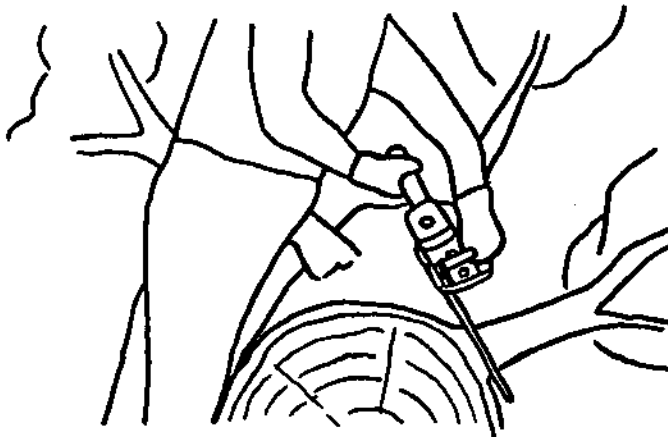

Limbing a fallen tree is much the same as bucking. Never limb on the tree that you are standing. When limbing, caution is the word. Be careful of the tip touching other limbs. Always use both hands.

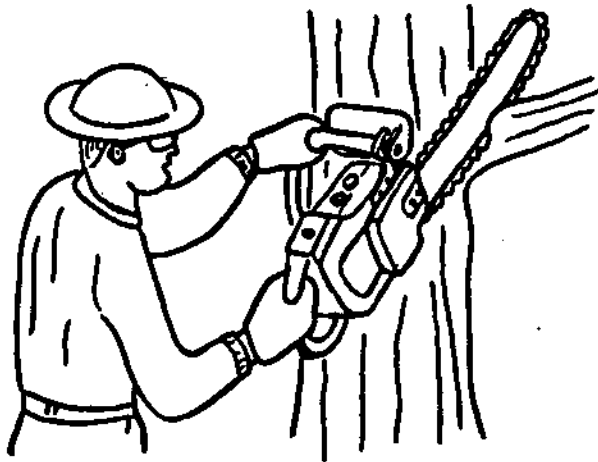

Don't cut with the saw overhead or the bar in a vertical position. If the saw should kick back you may not have good enough control to prevent possible injury.

BUCKING

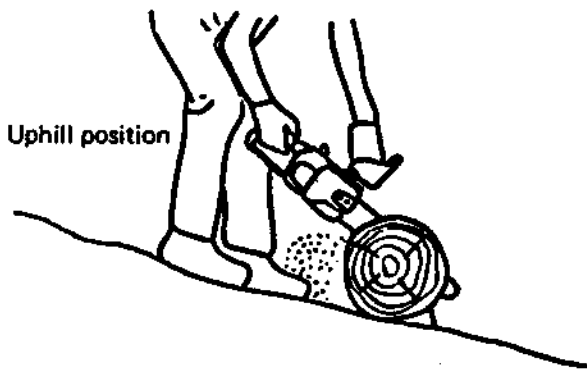

Bucking is the sawing of a log or fallen tree into smaller pieces. There are a few basic rules which apply to all bucking operations.

Keep both hands on the handles at all times.

Support logs if possible.

When cutting on a slope or hillside, always stand uphill.

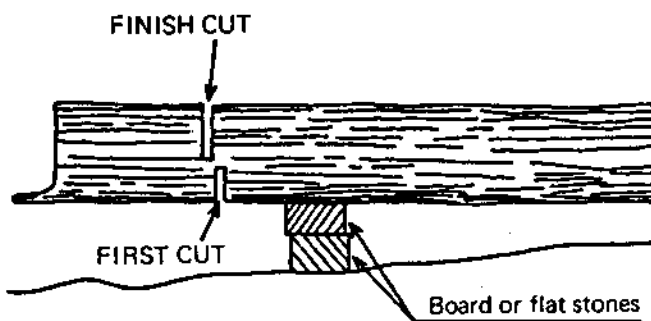

Keep in mind that the wood is heavy and that it will bend and pinch the saw if improperly supported.

The trunk will weaken at the point where you make the cut unless the tree is lying on perfectly flat ground or supported as shown.

If you make the cut with the tree on the ground, don't let the saw's chain dig into the earth; it is harmful for the saw, and you stand a good chance of being struck by flying debris. To cut the trunk, use the bucking and two-cut sequence shown. The first cut should be no deeper than one-third the trunk diameter.

Kickback Motion:

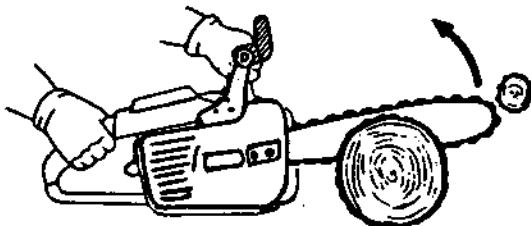

- When the bar nose hits another tree etc.

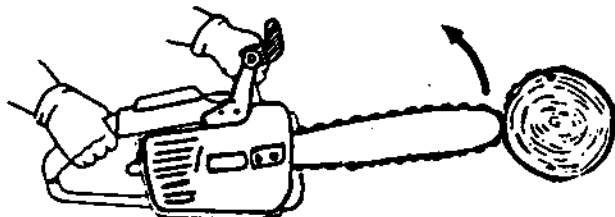

- Improper thrust cutting.

WARNING: KICKBACK IS DANGEROUS

- Kickback is generated when rotation of the chain is arrested for some reason. The most dangerous effect of this action occurs when the nose of the bar contacts another object, the chain is momentarily stopped and all the energy of engine throws the bar upwards and backwards towards the operator.
- The chain saw industry and government agencies have attempted to prescribe various safety devices, but the best protection is to avoid kickback.
- Comply with the Safety Precautions as listed on page 1 of this manual.

INFORMATION

Kickback Safety Features

The following features are recommended for this model as Kickback Safety Features.

- **Asymmetrical Low Kick Type Guide Bar**

The asymmetrical low kick type guide bar must be mounted with the reduced radius section of nose on top as illustrated. Incorrect installation will result in increased kickback potential.

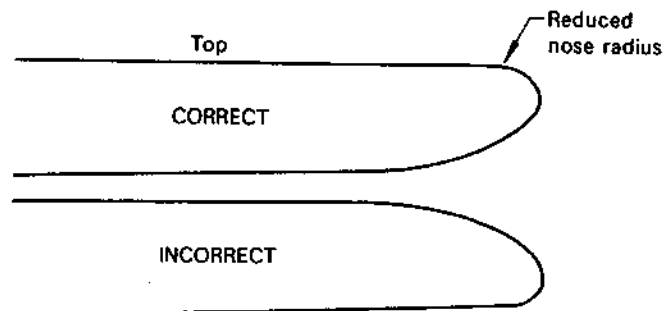

NOTE:

Replacement Guide Bars.

The following guide bars may be considered to have equivalent kickback energy.

- Sprocket nose guide bars of the same length and nose radius, same pitch and having the same number of teeth.
- A hard nose guide bar having the same length and nose radius as a sprocket nose bar.

- **Low Kick Guard Link Type Saw Chain**

The low kick guard link chain must be maintained correctly, follow instruction "SETTING THE CHAIN" in operator's manual.

- **Front Hand Guard**

The front hand guard must be installed correctly and kept in good condition.

- **Chain Brake**

The chain brake is available as a standard feature of the P-type model.

Chain brake must be maintained correctly, follow instruction "CORRECT USE OF CHAIN BRAKE" in operator's manual.

CAUTION!!

The consequences of using improper replacement components and of removing safety devices may result in serious or fatal injury.

MAINTENANCE AND CARE

CARBURETOR

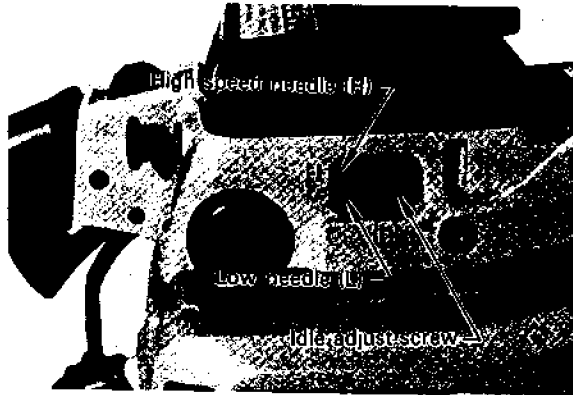

- Do not adjust the carburetor unless necessary.
- To adjust the carburetor, proceed as follows:
 - Low speed needle: (L) 1-1/8 ~ 1-3/8
 - High speed needle: (H) 3/4 ~ 1 1/4
 - Screw in the needles until lightly seated and return indicated turn above

CAUTION

Always open high speed needle MORE THAN 3/4 turn.

AIR FILTER

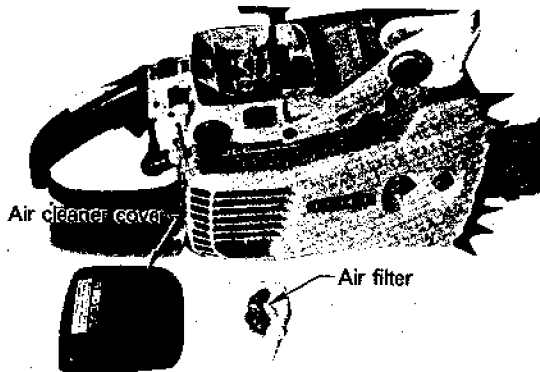

- Check before every use.
- Loosen thumb bolt, and remove air cleaner cover and filter.
- Brush off dusts lightly, or wash it in suitable cleaning fluid if necessary.
Dry it completely before installation.

FUEL STRAINER

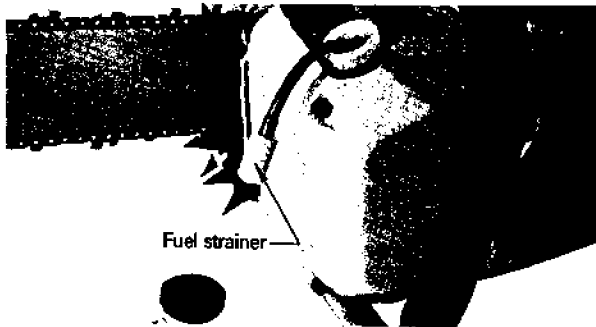

- Check periodically.
 - Do not allow dust to enter into fuel tank.
 - Clogged strainer will cause difficulty in starting engine or abnormalities in engine performances.
 - Pick up the fuel strainer through fuel inlet port with a piece of steel wire or the like.
 - When the strainer is dirty, wash it in suitable cleaning fluid. Dry it completely to remove moisture.
 - When the inside of the fuel tank gets dirty, it can be cleaned by rinsing the tank out with suitable cleaning fluid.

GUID BAR

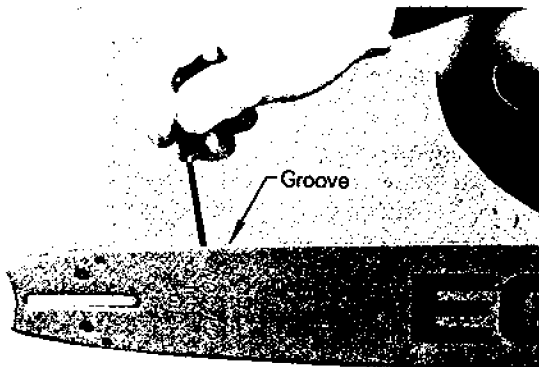

- Clean before cutting work.
 - Clean the groove of the guide bar with, for example, a small screw driver.
 - Clean oil holes with a wire.
- Clean sprocket, clutch and bar mount area before installation of bar.

SPROCKET

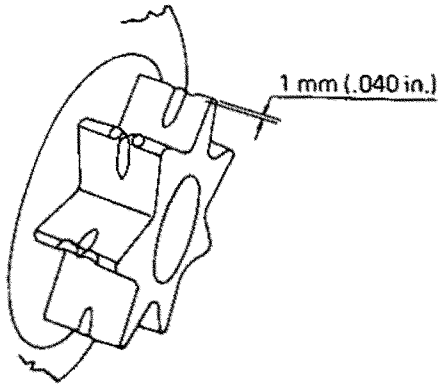

- The damaged sprocket causes premature damage or wear of saw chain.
 - When the sprocket has worn out 1.0 mm (.040 in.) or more, replace it.

- Check sprocket when you install new chain, specially. Replace it if worn.

AUTOMATIC OILER



- The discharge volume of the automatic oiler is adjusted to 8–12 cc/min. approx. at 8000 rpm, prior to shipment from factory.
 - To increase the delivery volume, turn the adjusting screw clockwise. When the screw touches stopper and stops, this position indicates maximum discharge volume. (20 ~ 25 cc/min. 8000 rpm)
 - Do not turn the adjusting screw beyond the max. or min. limit of volume adjustment.

OIL STRAINER

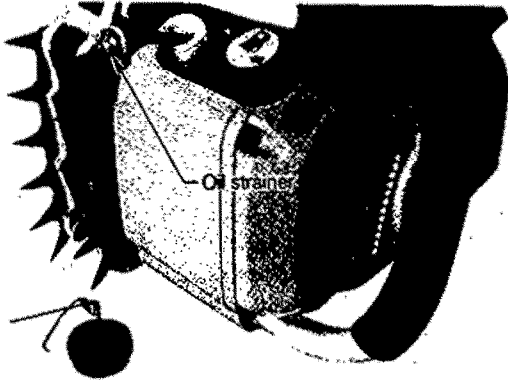

- Check periodically.
 - Do not allow dust to enter into oil tank.
 - Clogged oil strainer will cause troubles in the lubrication system.
 - Pick the oil strainer up through oil filling hole with a piece of steel wire or the like.
 - If the strainer is dirty, wash it in suitable cleaning fluid. Dry it completely to remove moisture.
 - When the inside of the tank gets dirty, it can be cleaned by rinsing the tank out with suitable cleaning fluid.

SPARK PLUG

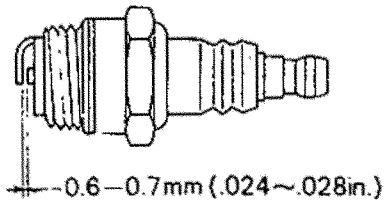

- Check periodically.
 - The standard spark gap is 0.6–0.7 mm (.024–.028 in)
 - Correct the spark gap if it is wider or narrower than the standard gap.
 - When it is fouled, clean it before fitting to the engine.
- Fastening torque = 145–155 kg·cm (125–135 in·lb).

CYLINDER FINS

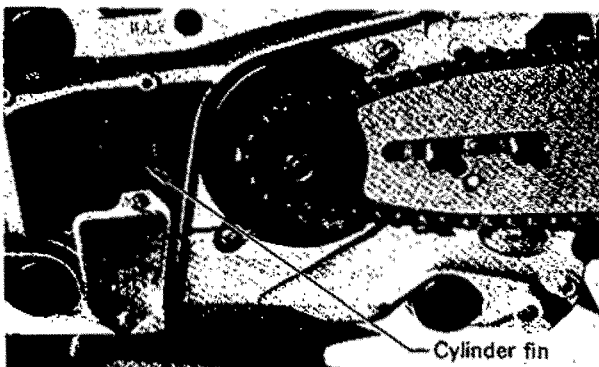

- Check periodically.
 - Clogged fins result in poor engine cooling.
 - Clean the passage of air between the cylinder fins to let cooling air pass easily.
- Check for loose nuts and screws on the muffler part before every use. Retighten them if necessary.

SETTING THE CHAIN

NOMENCLATURE OF PARTS

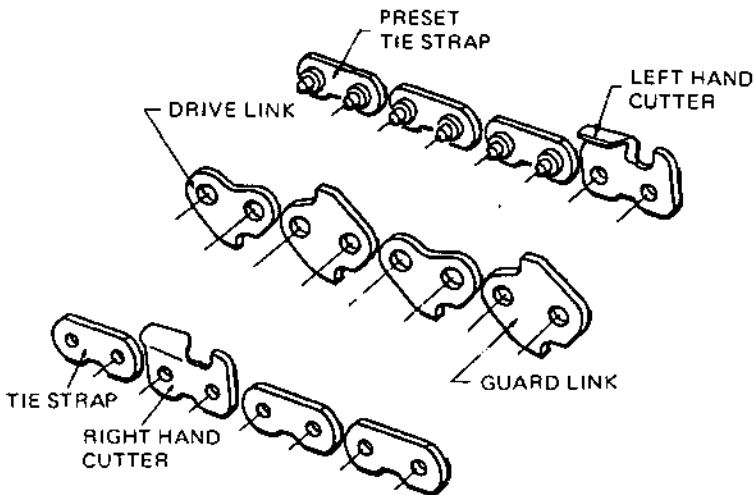

- Guard links reduce the potential of kickback.

CUTTER PART NAMES

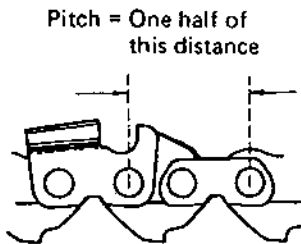
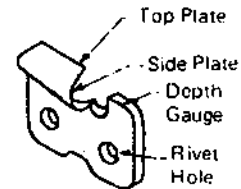

Pitch = One half of this distance

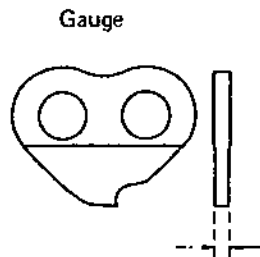

Gauge

Depth gauge setting

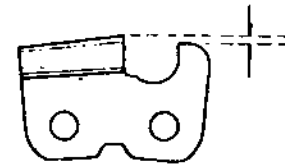

- Gauge is nominal width of guide bar groove and thickness of drive links.

- Depth gauge controls the cutting depth.

The important matters for saw chains are as follows.

- Keep the cutters sharp at all times.
- Keep the left and the right cutters properly aligned.
 - Please note that blunt or irregular cutters will result in poor cutting performance, increased vibration of chains and premature breakage of the chain saw.
- Drive link serves to remove sawdust from the groove of the guide bar. Therefore, keep the lower edge of the drive link sharp as indicated by the arrow.

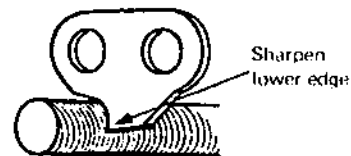
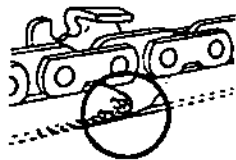

- When setting of the chain is finished, soak it in oil and wash away filings completely before using.
- When chain has been filed on the bar, supply sufficient oil on it, rotate the chain slowly to wash away the filings before using again.
- If the chain saw is operated with filings clogged in the groove, the saw chain and the guide bar will be damaged prematurely.
- If the saw chain becomes soiled with resin, for instance, clean it up with kerosene and soak it in oil.

For setting saw chains, round file (5.0 mmφ : 3/16") and flat file are used.

- To keep correct position and correct angle, use the file holder (Sure Sharp).
 - Round file (P-No. 897510-00330) and flat file (P-No. 897511-00230) are option.
 - Please inquire as to the details of file holder, if necessary.

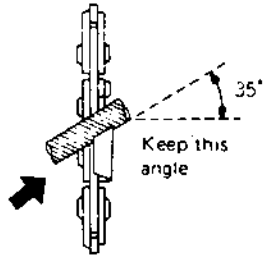

PUSH FILE AS SHOWN

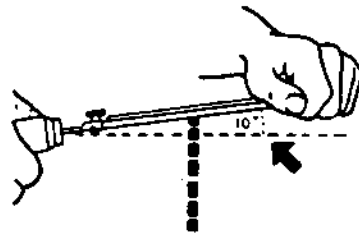

LOW FILE HANDLE 10°

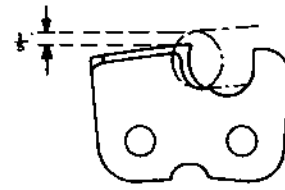

ONE FIFTH OF FILE DIAMETER
REMAINS ABOVE CUTTER EDGE.

- Place the depth gauge tool firmly on guide bar so that depth gauge protrudes. Then file top of depth gauge with flat file until flat with top of the depth gauge tool.
 - Round off the front edge without fail.

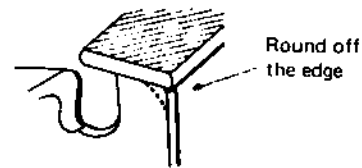
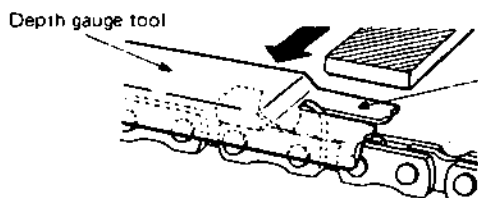

- Cutters, filed properly are as follows.

(Top plate angle)

(Side plate angle)

(Top plate cutting angle)

(Depth gauge)

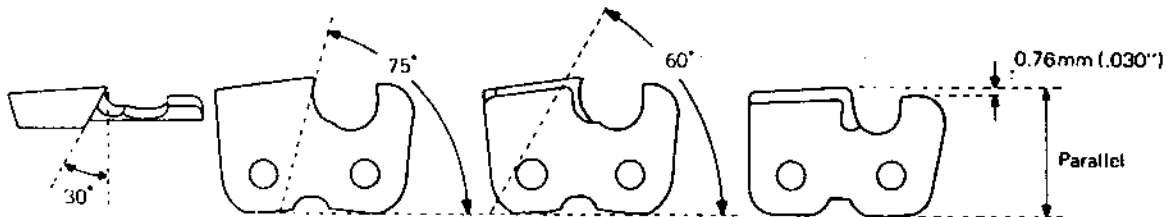

[NOTE]

Top plate angle becomes 30° when filed properly. (File angle 35°, and lowered file holder 10°)

These angles are referred to **Oregon 76SL**

To sharpen other type chain, follow chain manufacturer's instruction.

CHAIN AND GUIDE BAR COMBINATION

The following combinations are recommended to the models CS-510EVL and CS-510EVLP.

Guide Bar			Saw Chain		
Length	Parts No. *		Pitch	Type *	Links
	ECHO	OREGON			
16"	16A50	7929	3/8"	ORE. 76SL	60
18"	16D50	30591	3/8"	ORE. 76SL	60
20"	20A50	7930	3/8"	ORE. 76SL	70
20"	20D50	30590	3/8"	ORE. 76SL	70
24"	24A50	7931	3/8"	ORE. 76SL	81

* Or equivalent.

REMARKS: I) For example, CS-510EVLP is the model with chain brake.

II) "ORE" means "OREGON".

CAUTION!! Do not use replacement saw chain unless it has been designated as meeting the ANSI B175.1 kick back performance requirements.

On specific powerhead, or has been designated as "LOW-KICKBACK" saw chain in accordance with the ANSI B175.1 standard.

NOTE: Low kickback saw chain is the chain which has met the kickback performance requirements of ANSI B-175.1 (safety requirements for gasolinepowered chain saws) when tested on the representative sample of chain saws below 3.8 C.I.D. specified in ANSI B175.1.

TROUBLE SHOOTING

Poor performance of the engine and/or cutting mechanism can normally be prevented by carefully following instructions.

Poor performances can easily be corrected even by a beginner.

When the engine does not function properly check the following three (3) points first.

- Is engine compression adequate?
- Is fuel system in good condition and is enough fuel being supplied?
- Is electrical system in good condition and is spark plug operating normally?

When there is serious trouble with the unit, do not try to repair it yourself but have your distributor or dealer do it for you. For detailed **TROUBLE SHOOTING** refer to tables 1 and 2. Locate the problem on the following charts and repair as necessary.

Table 1

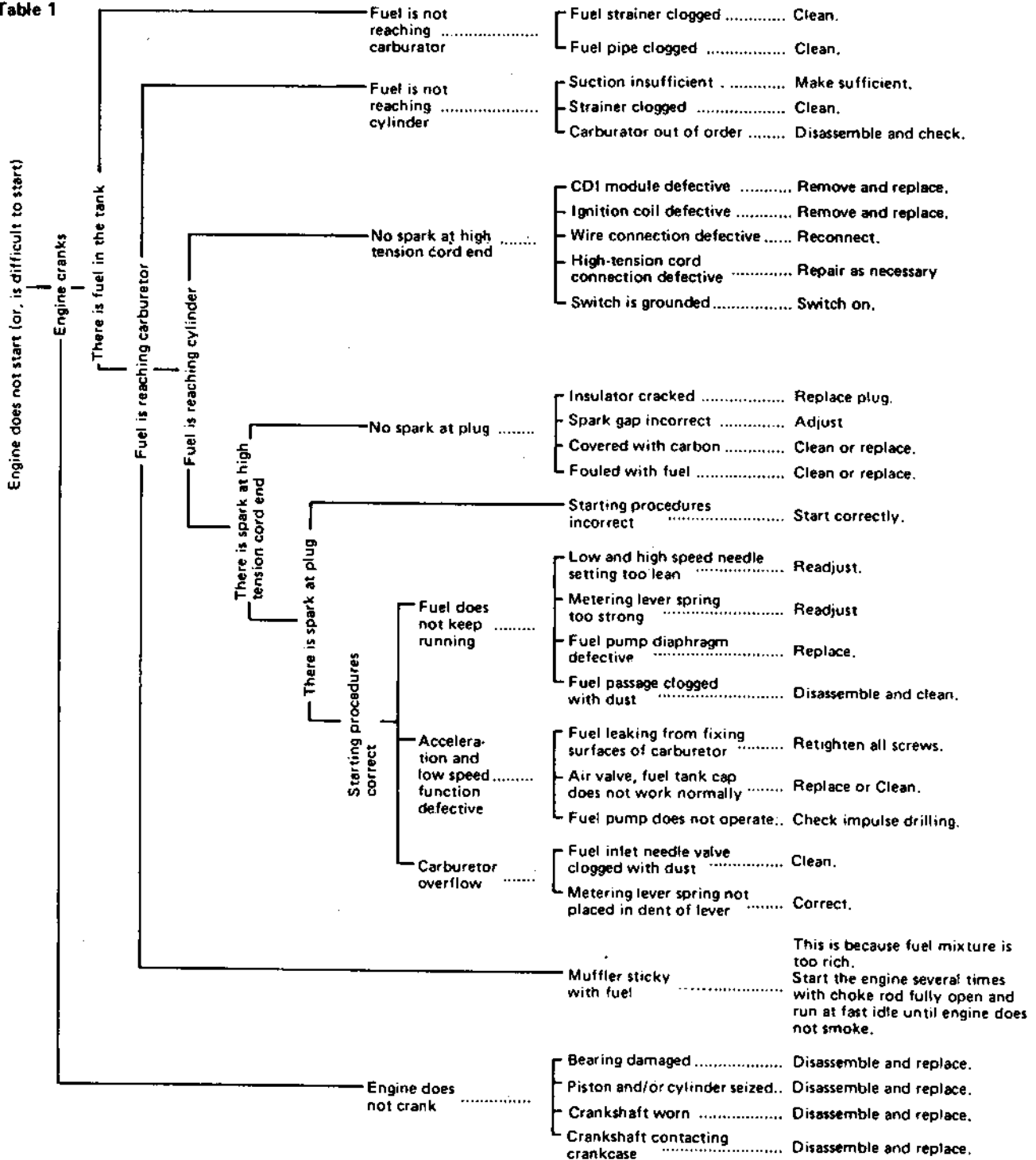
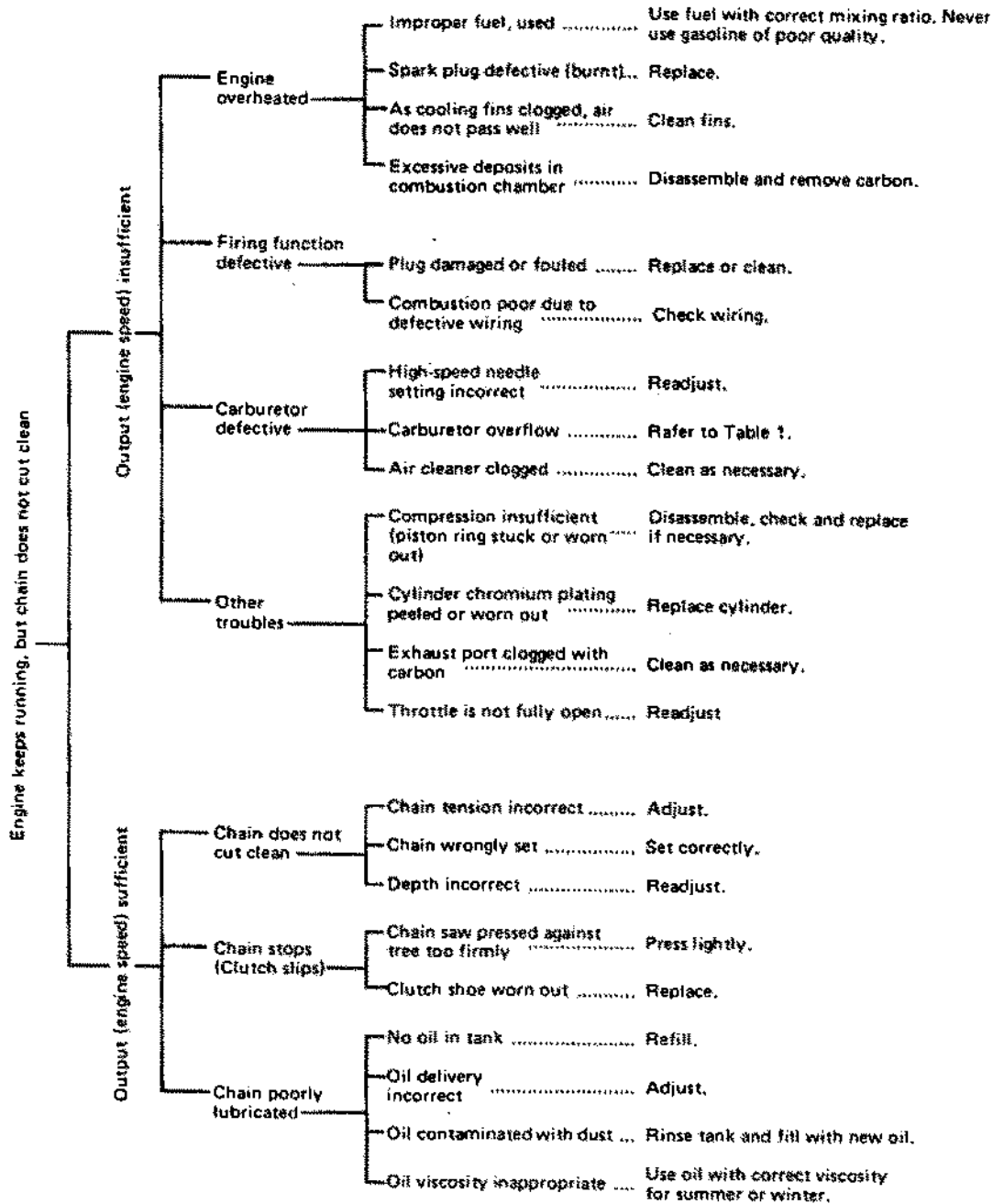

Table 2



STORAGE AFTER USE

- Inspect and adjust every part of the chain saw.
 - Completely clean every part, and repair, if necessary.
 - Apply thin coating of oil on metal parts to prevent rust.
 - Remove chain and guide bar, apply sufficient oil coating and wrap them up in plastic.
- Drain fuel tank, pull starter slowly a few times to drain fuel from carburetor.
- Pour a small amount of clean motor oil into spark plug hole, pull starter and crank the engine until the TOP DEAD CENTER.
- Store in a dry area, free from dust.

CHAIN BRAKE -- Model CS-510EVL Only

The installation of a chain brake may be mandatory by law or as stipulated by insurance regulations in your area of operation. You should enquire through local government offices, your employer or your local dealer to ensure that your chain saw conforms to the required safety standard. Echo chain brakes have been designed and tested to comply with international safety standards as follows.

USA: ANSI Standard B 175.1 Safety Requirement for chain saws

Canada: CSA Standard Z 62.1 CHAIN SAWS

WARNING:

- ANSI Standard B175.1 stipulates that the brake shall stop the chain in 0.10 seconds (one tenth) at an engine speed of 8000 RPM. It is the responsibility of the Owner/Operator to ensure that the brake is serviced, adjusted and tested strictly in accordance with the instructions as detailed herein in order to ensure that the brake performance is maintained in compliance with the Standard B 175.1.

- Echo recommends that the chain brake should be serviced by an authorized Echo servicing dealer.

OPERATION

The chain brake is engaged when the lever is in the forward position. The chain brake is disengaged when the lever is in the center position.

NOTE

The third position of the lever does not affect the brake and is intended only to provide better access to the fuel & oil caps.

- Set the lever in the center position before starting to cut.
- If the brake is tripped by kick back reaction, the chain will stop. Immediately release the throttle to avoid possible damage to the engine or clutch.
- Do not attempt to start or operate the engine with the brake engaged.

TESTING THE BRAKE

- Start the engine on a solid level surface and run at a fast idle until warm.
- Hold the saw firmly by the handles and accelerate the engine to a fast idle.
- Slowly operate the chain brake lever while holding the saw firmly on the ground. When the brake lever trips, the chain should stop. Immediately release the throttle trigger.

CAUTION

DO NOT ALLOW THE SAW TO TIP FORWARD IN ORDER TO AVOID DAMAGE TO THE CHAIN.

If the chain does not stop immediately return the saw to your authorized Echo dealer for repair.

MAINTENANCE

- Remove the guide bar cover.
- Remove the plastic cover over the brake.
- Clean oil and saw dust from complete chain brake area.
- Examine the drum, brake band and linkage for any indication of wear.

ADJUSTMENT

- Loosen the screw H securing the adjusting cam G .
- Rotate the cam counter clockwise to tighten the brake band. The band should not contact the drum.
- Tighten the securing screw H and again ensure that the band does not touch the drum.
- Check that the brake lever is spring locked firmly in each position.

If the lever will not move fully forward into the BRAKE ON position, readjust the band to provide more clearance.

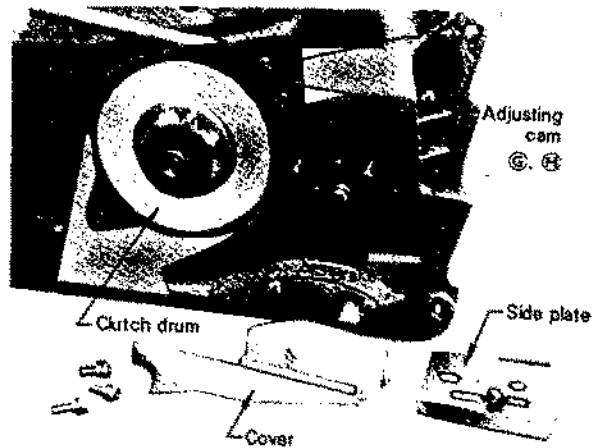

E KIORITZ CORPORATION

5-1. SHIMORENJAKU 7-CHOME, MITAKA, TOKYO 181, JAPAN
PHONE: 0422-48-6115 P.O. BOX 10 MITAKA TOKYO
CABLE ADDRESS: KIORITZ MITAKA TELEX: KIORITZ A J26592

ECHO, INCORPORATED

400 Oakwood Road, Lake Zurich, Illinois 60047
Phone : 312-540-8400



CAP INDICATION

Fuel/oil tanks are indicated by the following illustrations on the caps.



FUEL TANK CAP



OIL TANK CAP