

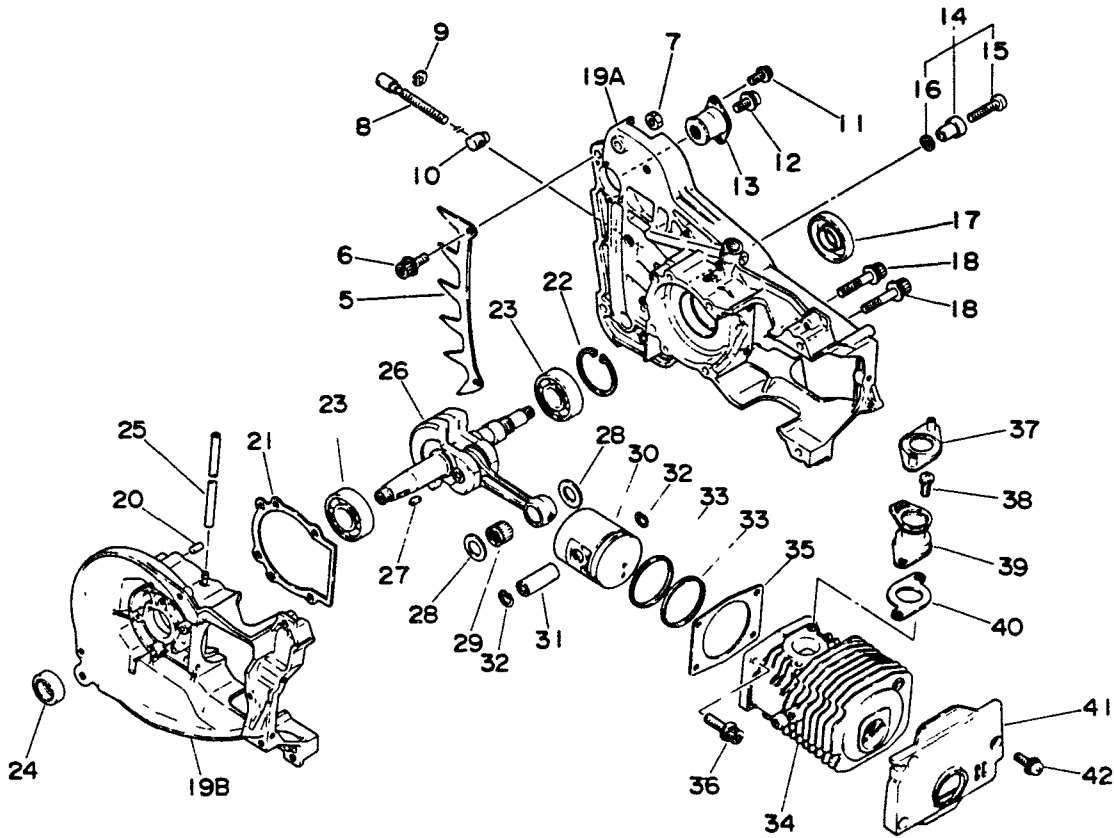

PARTS CATALOGUE

**ECHO
CHAIN SAW
CS-510EVL
CS-510EVL P**





Key No.	Part Number	Q'ty	Description	Key No.	Part Number	Q'ty	Description
1-	5	880 210-1433 0	1 Spike	1-	25	130 110-1233 0	1 Pipe, impulse
	6	900 106-0501 2	2 H S H bolt 5x12		26	100 100-1733 0	1 Crankshaft ass'y
	7	433 020-0083 0	2 Lock nut 5		27	100 142-1233 0	1 Key, woodruff
	8	433 016-1103 1	1 Screw, adjustment		28	100 014-1733 0	2 Spacer
	9	433 028-1103 0	1 Clip		29	100 012-1233 0	1 Bearing, needle
	10	433 014-0283 0	1 Tensioner		30	100 010-1523 0	1 Piston
	11	900 242-0401 0	2 Screw 4x10		31	100 013-0041 0	1 Pin, piston
	12	900 242-0501 0	1 Screw 5x10		32	100 015-0012 0	2 Circlip, piston pin
	13	100 921-1233 1	1 Cushion		33	100 011-1233 0	2 Ring, piston
	14	433 000-1283 0	1 Catcher, chain kit		34	101 011-1523 0	1 Cylinder
	15	-900 220-0502 5	1 Screw 5x25		35	101 010-1233 0	1 Gasket
	16	-900 600-0000 5	1 Washer 5		36	900 162-0502 0	4 H S H bolt 5x20
	17	100 213-0283 0	1 Oil seal		37	130 034-1233 1	1 Seal
	18	900 162-0503 0	6 H S H bolt 5x30		38	900 241-0501 0	2 Screw 5x10
	19	100 200-1523 0	1 Crankcase set		39	130 508-1233 1	1 Adapter, intake
	20	-100 215-0393 0	2 Knock		40	130 010-1233 0	1 Gasket
	21	100 242-1523 0	1 Gasket		41	101 514-1523 0	1 Cover, cylinder
	22	900 702-0003 5	1 Circlip		42	900 242-0401 4	3 Screw 4x14
	23	900 810-0620 2	2 Bearing, ball				
	24	100 213-0031 0	1 Oilseal				

Remarks: 19 Includes 20.

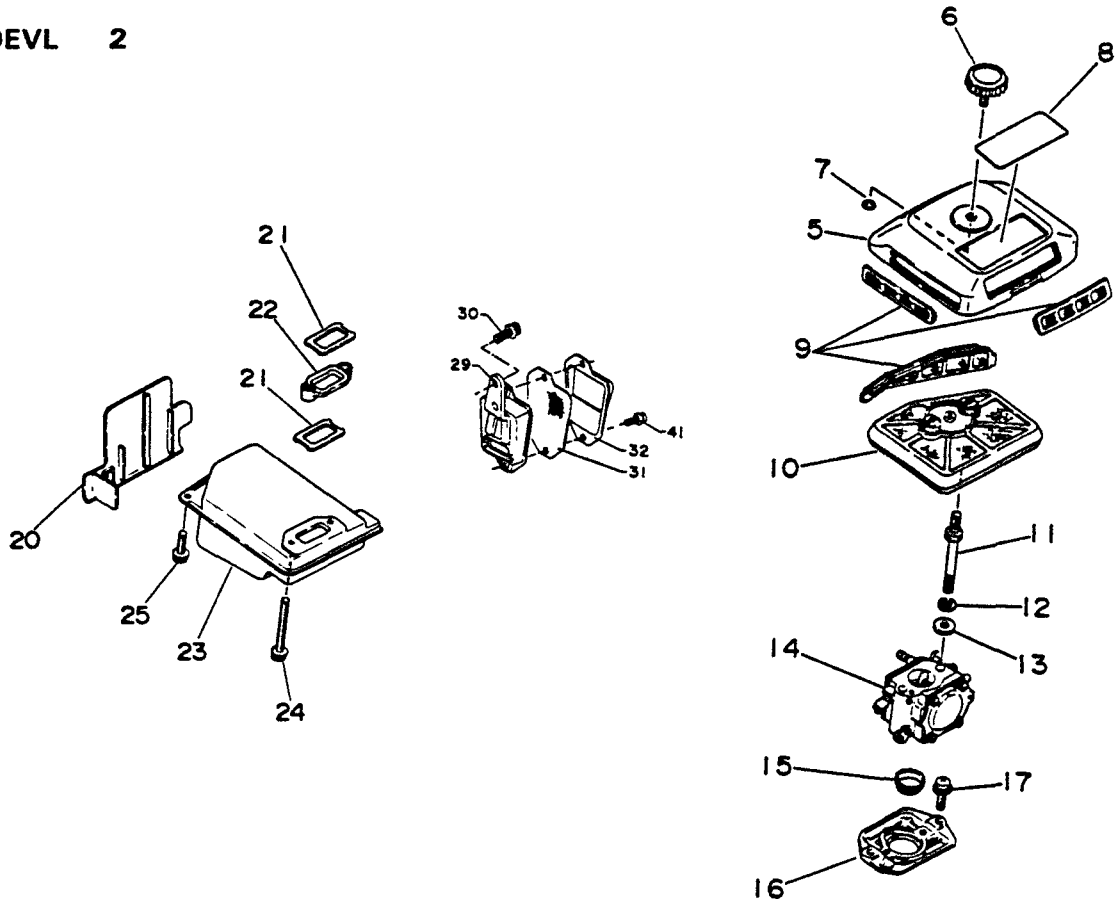

Key No.	Part Number	Q'ty	Description	Key No.	Part Number	Q'ty	Description		
2-	5	130 813-1523 0	1	Cover, air cleaner	2-	20	100 270-1523 0	1	Insulator
	6	130 406-1433 0	1	Nut, thumb	21	145 510-1523 0	2	Gasket	
	7	900,720-0000 3	1	O-ring 3	22	145 511-1523 0	1	Adapler	
	8	890 151-1833 1	1	Decal	23	145 810-1233 0	1	Muffler	
	9	130 811-1523 0	1	Screen kit , dust	24	900 162-0504 5	2	H S H bolt 5x45	
	10	130 801-1523 0	1	Filter, air	25	900 162-0502 0	1	H S H bolt 5x20	
	11	130 021-1523 0	2	Stud	29	145 806-1523 0	1	Adapter	
	12	900 605-0000 5	2	Lock washer	30	900 162-0501 4	2	H.S.H.bolt 5x14	
	13	100 247-0283 0	2	Washer	31	145 862-1523 0	1	Screen	
	14	123 000-1833 2	1	Carburetor	32	145 863-1523 0	1	Holder, screen	
	15	130 511-1233 0	1	Holder, adapter	41	900 242-0401 0	2	Screw 4x10	
	16	130 013-1233 1	1	Adapter					
	17	900 242-0401 2	2	Screw 4x12					

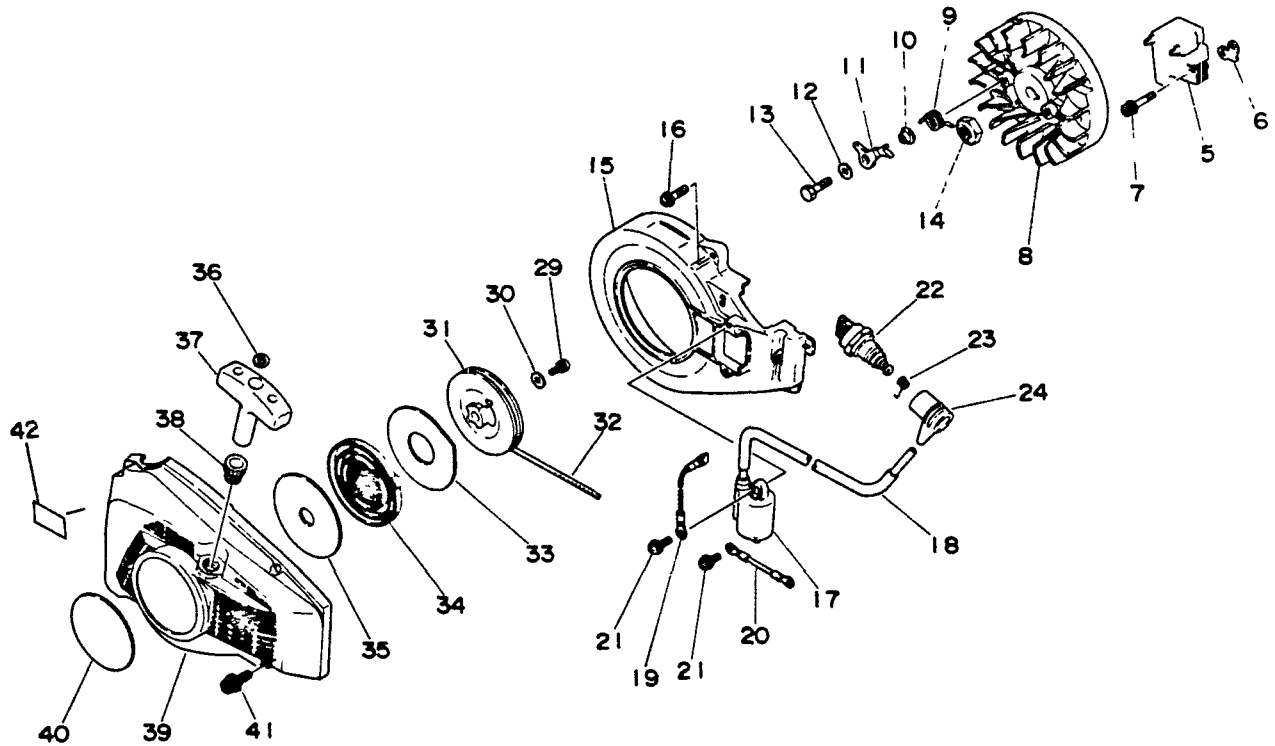

Key No.	Part Number	Q'ty	Description	Key No.	Part Number	Q'ty	Description
3-	5	1	C.D Ignition module	3-	* 177 200-1253 1	1	Starter ass'y
	6	1	Spacer		29	1	Screw 5x10
	7	2	H S H bolt 4x22		30	1	Washer 5
	8	1	Flywheel		31	1	Reel, starter
	9	2	Spring, pawl		32	1	Rope
	10	2	Spacer		33	1	Plate
	11	2	Pawl, starter		34	1	Spring, rewind
	12	2	Washer 5		35	1	Plate
	13	2	Bolt 5x20		36	1	Spacer
	14	1	Nut		37	1	Grip
	15	1	Cover, fan inner		38	1	Guide, rope
	16	4	Screw 4x20		39	1	Cover, fan
	17	1	Coil, ignition		40	1	Decal
	18	1	Tube		41	4	H S H bolt 5x20
	19	1	Lead		42	1	Decal, noise
	20	1	Lead				
	21	2	Screw 4x14				
	22	1	Plug, spark CJ-7Y				
	23	1	Coil, plug cap				
	24	1	Cap, spark plug				

Remarks: * Consists of 29 thru 39.

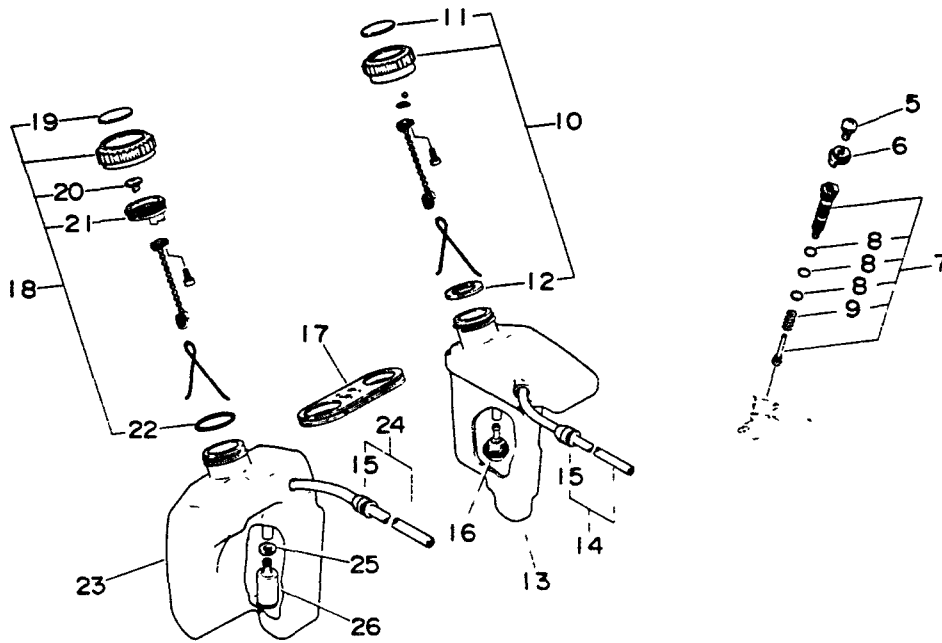

Key No.	Part Number	Q'ty	Description	Key No.	Part Number	Q'ty	Description
4-	5	1	Screw 5x10	4-	20	1	Valve check
	6	1	Stopper		21	1	Holder
	7	1	Auto oiler ass'y		22	1	O-ring 22
	8	3	O-ring		23	1	Tank, fuel
	9	1	Spring	24	1	Pipe	
10	1	Cap ass'y, oil	15	1	Grommet		
11	1	Decal	25	1	Washer 5		
12	1	Gasket	26	1	Strainer, fuel		
13	1	Tank, oil					
14	1	Pipe					
15	1	Grommet					
16	1	Strainer, Oil					
17	1	Connector					
18	1	Cap ass'y, fuel					
19	1	Decal					

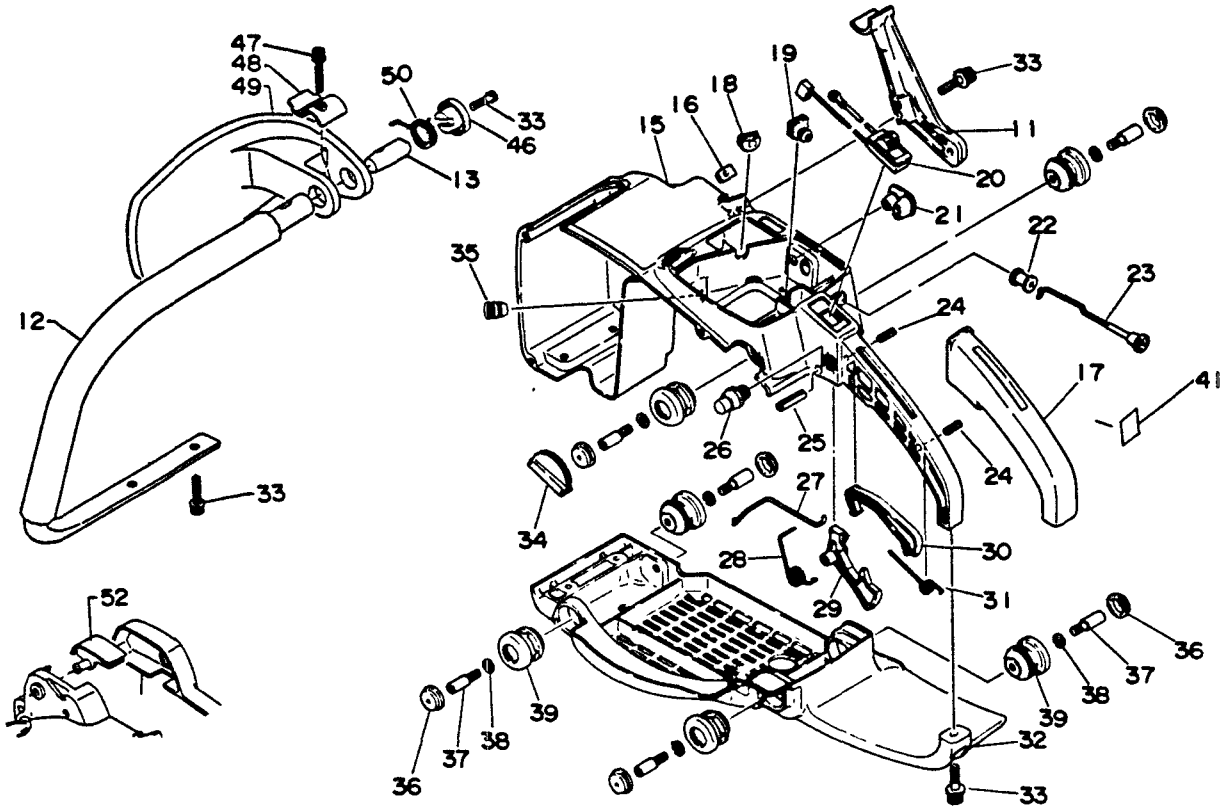

Key No.	Part Number	Q'ty	Description	Key No.	Part Number	Q'ty	Description
5- 11	351 614-1733 0	1	Supporter	5- 32	351 123-1253 1	1	Supporter
12	351 606-1733 0	1	Handle, front	33	900 162-0502 0	6	H S H bolt 5x20
13	-351 617-1633 0	1	Insert	34	351 138-1433 2	1	Cover, cushion
15	351 110-1233 1	1	Handle, rear	35	132 115-1233 0	1	Grommet
16	351 137-1233 0	1	Stopper	36	100 918-1433 0	6	Plug
17	351 111-1233 0	1	Grip, rear handle	37	100 915-1433 2	6	Screw
18	130 114-1233 0	1	Grommet	38	900 605-0000 5	6	Lock washer
19	178 210-1233 0	1	Grommet	39	100 910-1253 0	6	Cushion
20	163 400-1523 0	1	Switch, stop	41	890 121-1233 1	1	Decal, choke
21	129 010-1233 0	1	Grommet	46	351 833-1513 0	1	Retainer
22	178 810-1123 1	1	Grommet	47	900 162-0503 5	1	H.S.H. bolt
23	178 510-1233 0	1	Rod, choke	48	351 840-1833 0	1	Stopper
24	900 340-4001 3	2	Pin, spring	49	351 826-1433 0	1	Hand guard, front
25	900 340-5002 5	1	Pin, spring	50	351 836-1373 0	1	Spring, return
26	178 302-1233 0	1	Latch, throttle	52	100 612-1233 2	1	Cover
27	178 011-1233 1	1	Rod, throttle				
28	178 043-1513 0	1	Spring, return				
29	178 010-1233 3	1	Trigger, throttle				
30	178 090-1233 0	1	Lockout, throttle				
31	178 091-1053 1	1	Spring				

Remarks: 12 Includes 13.

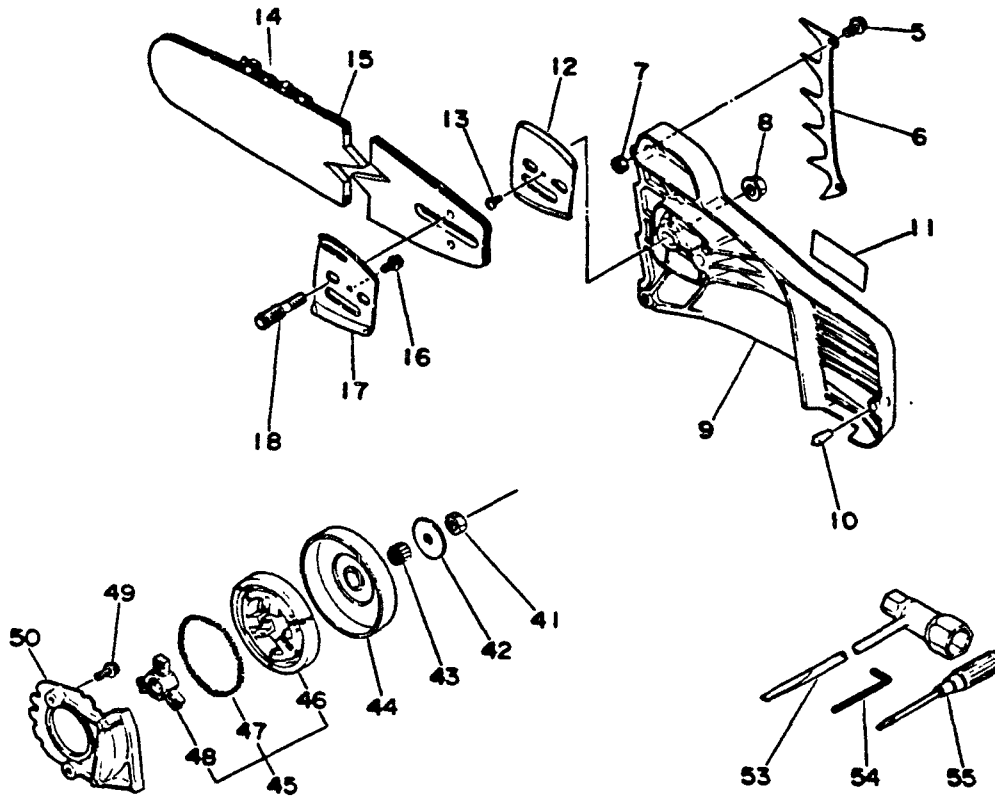

Key No.	Part Number	Q'ty	Description	Key No.	Part Number	Q'ty	Description	
6-	5	2	H.S.H. bolt 5x12	41	100 129-0343 0	1	Nut	
	6	1	Spike	42	175 015-0343 0	1	Washer	
	7	2	Nut, lock	43	100 012-1233 0	1	Bearing, needle	
	8	2	Nut	44	175 005-1433 0	1	Drum, clutch	
	9	1	Guard, sprocket	45	175 000-1233 0	1	Clutch ass'y	
	10	433 030-1443 0	1	Knock	46	-175 017-0283 0	3	Shoe
	11	890 118-1833 1	1	Decal, ECHO	47	-175 018-0283 0	1	Spring
	12	433 012-1233 2	1	Plate, outer	48	-175 016-0343 0	1	Hub
	13	900 220-0300 6	2	Screw 3x6	49	900 242-0401 4	2	Screw 4x14
	14	_____	1	Chain	50	175 310-1523 0	1	Seal plate
	15	_____	1	Bar, guide	53	895 410-0283 0	1	Wrench
	16	900 242-0401 0	1	Screw 4x10	54	895 610-0013 0	1	L-wrench 4
	17	433 013-1233 2	1	Plate, inner	55	895 812-0393 0	1	Screw driver
	18	433 011-1233 0	2	Stud				

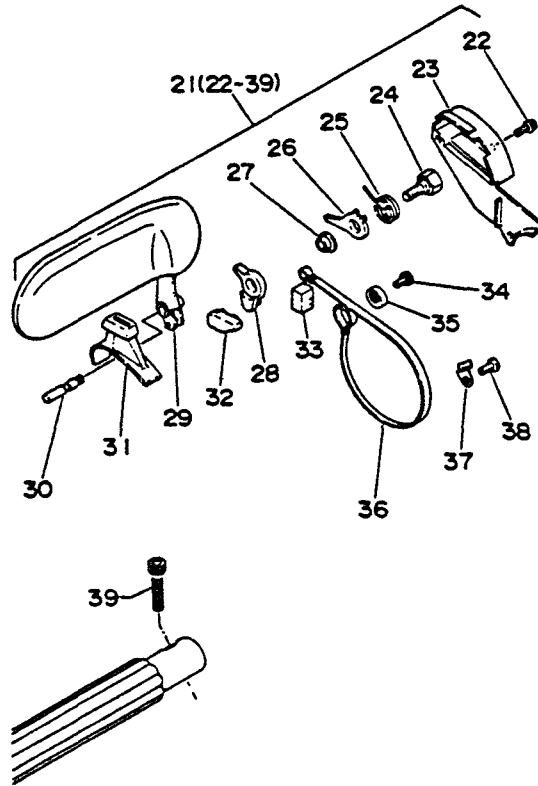

Key No.	Part Number	Q'ty	Description
21	433 100-1733 0	1	Brake ass'y, chain
22	-900242-0401 0	3	Screw 4x10
23	-433 310-1233 0	1	Cover
24	-433 134-1233 0	1	Bolt
25	-433 114-1233 0	1	Spring
26	-433 119-1233 0	1	Stopper
27	-433 115-1233 0	1	Spacer
28	-433 117-1233 0	1	Connector
29	-433 105-1733 0	1	Handle
30	-433 113-1233 0	1	Shaft
31	-433 312-1233 0	1	Cover, lever
32	-433 149-1253 0	1	Reset rubber
33	-433 313-1233 0	1	Seal
34	-900 241-0501 0	1	Screw 5x10
35	-433 142-1233 0	1	Adjuster
36	-433 123-1233 0	1	Band, brake
37	-433 144-1433 0	1	Retainer
38	-900 220-0501 0	1	Screw 5x10
39	-900 162-0502 5	1	H.S.H. bolt 5x25