



OWNER'S AND OPERATOR'S MANUAL

Diesel Engine Generator DGK180F

Vertical, Water-Cooled 4-Cycle Diesel Engine

California Proposition 65

 **WARNING**

Breathing diesel engine exhaust exposes you to chemicals known to the State of California to cause cancer and birth defects or other reproductive harm.

- Always start and operate the engine in a well ventilated area.
- If in an enclosed area, vent the exhaust to the outside.
- Do not modify or tamper with the exhaust system.
- Do not idle the engine except as necessary.

For more information go to www.P65warnings.ca.gov/diesel.

 **WARNING**

Cancer and reproductive Harm-

www.P65Warnings.ca.gov

 **WARNING**

Batteries, battery posts, terminals and related accessories contain lead and lead compounds, and other chemicals known to the State of California to cause cancer and birth defects or other reproductive harm. WASH HANDS AFTER HANDLING.

 **CAUTION**

Do not operate the Generator, or any other appliance, before you have read and understood the instructions for use and keep near for ready use.

DGK180F
X753-007 87 0
X753801-300 0

Introduction

Thank you for purchasing this Shindaiwa soundproof diesel engine generator.

- This manual has been created to ensure safe usage of this generator. Be sure to read this manual before operation. Improper operation/handling of this generator will result in an accident or malfunction.
- Handling/Operation of this generator can only be performed by persons who understand the contents of this manual and can handle/operate the generator in a safe manner. Persons who suffer from an illness, are taking medicine or not feeling well such that safe operation would be negatively affected must not operate this generator.
- Work performed using this generator and handling/operation of this generator must be in accordance with corresponding laws and regulations based on such laws. Consult with the authorized distributor where this generator was purchased if you have any inquiries regarding the corresponding laws.
- Always be sure to include this manual when loaning out this generator and instruct operating personnel to read this manual before operation.
- Store this manual in a specified location where it will be secure and available for consulting at any time. Order another copy from the authorized distributor where this generator was purchased if this manual becomes dusty, grimy or torn.
- Consult with the authorized distributor where this generator was purchased if you have any inquiries regarding any points related to this generator and manual.
When inquiring about this generator, be sure to provide the model name and serial number.
- If disposing of this generator, do so in a manner that is in compliance with laws related to industrial waste. Contact the authorized distributor where the generator was purchased if you have any inquiries regarding proper disposal.

■ Caution notice ranks in this manual are classified as follows.

 **WARNING** : Indicates a potentially hazardous situation which, if not avoided, can result in death or serious injury.

 **CAUTION** : Indicates a potentially hazardous situation which, if not avoided, can result in minor or moderate injury and property damage.

< **Note** > : Other types of cautions and indications.

- Note that  **CAUTION** items can also lead to major accidents under some circumstances if not correctly followed.
All caution notices are important. Be sure to follow all of them.

Table of Contents

1. Safety Instructions	2
2. Specifications	6
2-1. Specifications	6
2-2. Ambient Conditions	7
3. Applications	7
4. Part Names	7
4-1. External View/Part Names	7
4-2. Operation Panel Configuration	10
5. Equipment	11
5-1. Three-phase and Single-phase simultaneous Output	11
5-2. Available Output Monitor	11
5-3. Spill Containment	12
5-4. Warning Indicators	13
5-5. SCR (Selective Catalytic Reduction) System and Indicators	15
5-6. Meters and Gauges	18
5-7. Fuel Piping Switch (3Way Fuel Valve)	22
5-8. Load Bank Control Switch	22
6. Transport/Installation	23
6-1. Transport Procedures	23
6-2. Installation Procedures	23
7. Load Connections	24
7-1. Load Cable Selection	24
7-2. Connecting Load Cables	26
8. Pre-Operation Inspection	29
8-1. Checking Engine Oil	29
8-2. Checking Coolant	30
8-3. Checking the Fan Belt	31
8-4. Checking the Fuel	32
8-5. Checking the DEF (Diesel Exhaust Fluid)	32
8-6. Checking the Spill Containment	33
8-7. Checking for Fuel, Oil and Coolant Leak	33
8-8. Checking the Battery	33
9. Operating Procedures	35
9-1. Initial Startup/Pre-Check	35
9-2. 208/240/480V Switching Selection	37
9-3. Procedures during Operation	38
9-4. Stopping Operation	39
9-5. Protective Functions	40
9-6. Connecting with External Fuel Tank	41
10. Inspection/Maintenance	42
11. Long-Term Storage	55
12. Troubleshooting	56
13. Generator Circuit Diagram	59
14. Engine Electrical Circuit Diagram	60

1. Safety Instructions

WARNING : EXHAUST GAS POISONING

- Do not operate the generator in poorly ventilated areas such as indoors or tunnels, as the exhaust gas of the engine contains substances that are harmful to human health.
- Do not direct exhaust fumes at bystanders or buildings.

WARNING : ELECTRIC SHOCK

- Do not operate the equipment with any doors or covers open.
- Always turn all the breakers OFF, place the starter switch in the STOP position and stop the engine before connecting / disconnecting the load cable to the output terminal or receptacle.
- Close the output terminal cover before operating.
- Do not insert a pin, wire or other metal object into the electrical outlet.
- Do not touch the generator if the generator or casing or your body becomes wet during operation.
- Do not touch internal electric parts while the generator is operating.
- Always turn the starter switch to the STOP position and stop the engine, then close and lock OPERATION PANEL DOOR before checking or maintaining the engine or any equipment.

WARNING : INJURY

- Close all doors and lock them during operation.
- Do not open the check door when the starter switch is in the AUTO or START position. It will cause injury by rotating parts such as cooling fans and fan belt.
- Always turn the starter switch to the STOP position and stop the engine, then close and lock OPERATION PANEL DOOR before checking or maintaining the engine or any equipment.
- Use the lifting hook to lift the machines, and do not lift up by using other parts. Use of such could result in the generator falling.
- Do not attempt to lift the equipment with any additional weight such as optional fuel tanks or trailers.
- No persons should ever be under a lifted generator.
- Always be sure to check that the breakers on load side and switches for any equipment using the generator are at OFF before turning the breaker to ON. Also be sure to advise personnel on the load side that power will be turned on or off before operating the breaker.
- Do not modify the equipment and do not operate with parts removed.

CAUTION : EYE/SKIN INJURY

- Wear rubber gloves and other protective wear to protect eyes, skin and clothing from the battery fluid which contains diluted sulfuric acid. If the battery fluid contacts eyes or skin, wash out immediately with a sufficient amount of clean water. Be sure to receive medical treatment, especially if the fluid contacts the eyes.

CAUTION : EXPLOSION

- Never use or recharge the battery if the fluid level is below the minimum level.
- Do not create sparks or bring flame near the battery as it generates flammable gas.

⚠ CAUTION : FIRE 

- Do not carry flammable items (such as fuel, gas and paint) or items that are highly combustible near the generator as the muffler, exhaust gas and other parts become extremely hot.
- Position this generator 3 ft. (1 m) or more from walls or other hindrances, and on a level surface.
- Do not connect the generator output to indoor wiring.
- This generator uses diesel fuel. Always be sure to stop the engine and not bring flames close when inspecting fuel or refueling. Wait until the engine has cooled before performing such procedures.
- If fuel spills, always be sure to wipe and drain off spilled fuel.
- Do not operate the equipment with liquid accumulated in the spill containment.
- If fuel or oil is leaking, repair the leaking location before operating.
- Always be sure to wipe up any spilled fuel or oil.
- Allow the generator to cool before covering with the protective cover.
- Never allow flame to come close to the generator.
- Always make sure that the engine is stopped when working on piping.
- After working on the piping, check that there is no fuel leakage.
- Absolutely never inspect or perform maintenance to the equipment near fire or other open flame.
- Do not put anything other than DEF (gasoline, diesel fuel, etc.) in the DEF tank. Also, do not put DEF diluted with water or other liquids.

⚠ CAUTION : ELECTRIC SHOCK 

- Do not sprinkle water on the equipment and do not use where exposed to rain.

⚠ CAUTION : BURNS 

- Do not touch the engine and surrounding components immediately after stopping the engine as they are still extremely hot.
- Do not open the radiator cap immediately after stopping the engine. Doing so will result in hot steam gushing out.
- Hot steam gushes out from the coolant sub-tank if the generator overheats. Do not touch the coolant sub-tank.
- Always be sure to stop the engine and allow the engine to cool when performing inspection or maintenance of engine oil. Opening the oil level gauge or oil filler cap during operation will result in hot oil gushing out.
- While the engine is running, the SCR system is purging, and immediately after operating, the SCR system and exhaust piping is extremely hot. Be careful not to inadvertently touch them.
- Do not touch the SCR system and surrounding components immediately after stopping the engine as they are still extremely hot.

⚠ CAUTION : INJURY 

- Always be sure to use lifting hooks when lifting up the generator, and slowly lift it straight up.
- Personnel performing lifting work must wear protective gear such as helmets, safety shoes and gloves.
- Position the generator on a level stable surface so that it cannot slide or move in any manner.
- Before starting operation, always be sure to turn off all switches of equipment using the generator and all breakers to OFF.
- Do not move the generator during operation.
- Do not operate the generator if it has been modified or any parts have been removed.
- Securely fix the equipment with rope or similar item to avoid any unexpected move when transporting by truck or other vehicle.

⚠ CAUTION : PROPERTY DAMAGE

- Do not use the equipment for any improper applications. Improper usage can result in an accident or malfunction.
- If using this generator for medical equipment, check before use with the medical equipment manufacturer, doctor, hospital or similar entity.
- Check that the generator output setting, output terminal connection and load power source are consistent.
- Cable burnout can occur due to generated heat if the load current exceeds the allowable current of the cable.
- The voltage drop between cables is large if the cable is excessively long or thin, resulting in decreased input voltage to equipment using the generator, thereby causing decreased performance, faulty operation and malfunction.

■ Warning /Caution Label Locations

If warning or caution labels become damaged and difficult to read, replace with new labels in the indicated locations. Order labels using part number indicated in the parenthesis.

- | | |
|---|-----------------------|
| ① Caution: Do not change voltage | Part no. :X505-004620 |
| ② Warnig caution | Part no. :X505-010910 |
| ③ Caution: Auto start | Part no. :X505-010800 |
| ④ Warning: Proposition 65 Gen | Part no. :X505-010400 |
| ⑤ EPA emission complied notice | Part no. :X505-008400 |
| ⑥ Warning: Fire | Part no. :X505-007650 |
| ⑦ Notice: Capacity of the external tank | Part no. :M709-000140 |
| ⑧ Terminal cover instructions | Part no. :M704-002250 |
| ⑨ Continuous output | Part no. :M705-001500 |
| ⑩ Warning: Electric shock | Part no. :X564-000400 |
| ⑪ DEF / AdBlue [®] Complied notice | Part no. :M708-000070 |
| ⑫ Warning: Injury | Part no. :X505-007550 |
| ⑬ Caution: GM SPEC LLC | Part no. :X505-007840 |
| ⑭ Warning: Proposition 65 Battery | Part no. :X505-010410 |

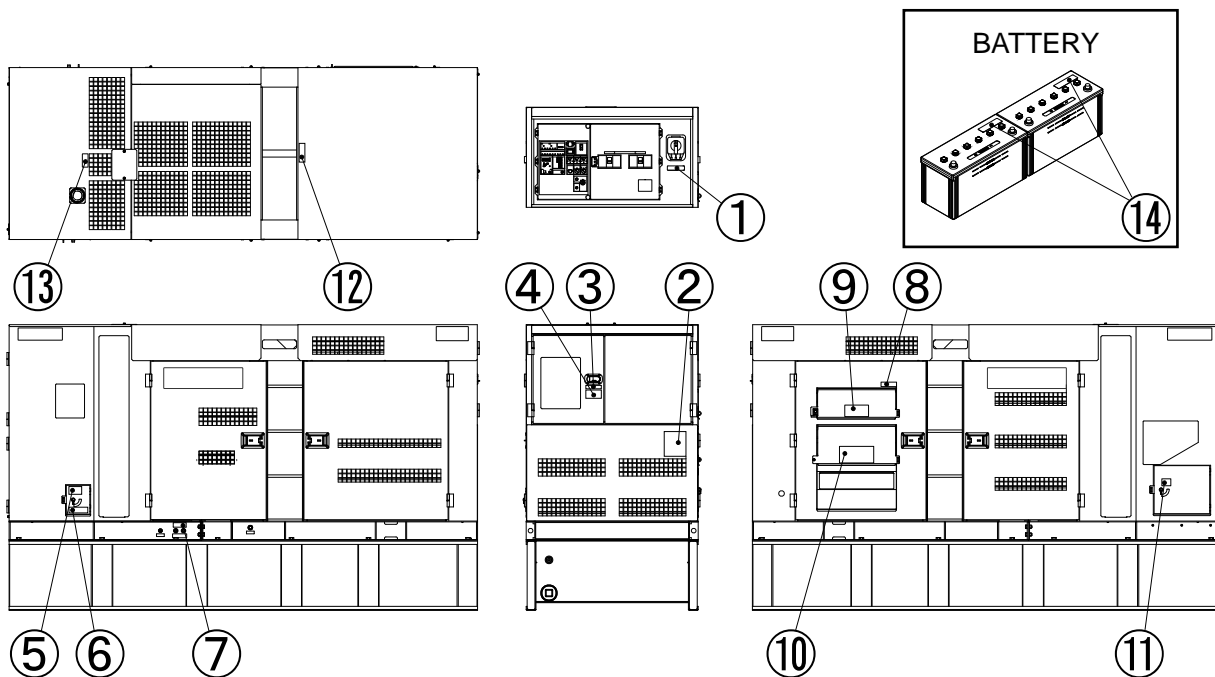

2. Specifications

2-1. Specifications

Model		Unit		DGK180F	
Alternator	Generator Type	-		Revolving Field Brushless	
	Rated Frequency	Hz		60	
	Rated Output(Prime)	Three phase	kVA	180	
			kW	144	
		Single phase	kVA	108 [54] *1	
			kW	108 [54] *1	
	Standby Output	Three phase	kVA	198	
			kW	158	
		Single phase	kVA	118.8 [59.4] *1	
			kW	118.8 [59.4] *1	
	Rated Voltage	Three phase	V	208/240/ [480] *1	
		Single phase	V	120/139/240/[277] *1	
	Rated Current	Three phase-208V	A	500	
		Three phase-240V	A	433	
		Three phase-480V	A	216	
		Single phase-120V	A	450 x 2 [225 x 2]*1	
Single phase-240V		A	450 [225]*1		
Power Factor	-		Three phase 0.8, Single phase 1.0		
Insulation class	-		F		
Excitation	-		Self Excitation (brushless)		
No. of Poles	-		4		
Engine	Type	-		Vertical Water-Cooled 4-Cycle Diesel	
	Model(Manufacturer)	-		6HK1X(ISUZU)	
	No. of Cylinders (bore x stroke)	(in./mm)		6(4.53x4.92/115x125)	
	Continuous Rated Output	hp		227.3	
	Rated Speed	rpm		1,800	
	Displacement	cu.in./liters		475/7.790	
	Combustion System	-		Direct injection (Turbo-charged)	
	Cooling Method	-		Water cooled	
	Starting Method	-		Electric	
	Fuel	-		No.2-D,S15 EPA regulation	
	Diesel Exhaust Fluid	-		ISO 22241 or API standard	
	Lubricating Oil	-		API service-type CJ-4 class	
	Fuel Tank Capacity	gal./liters		275.3/1042	
	DEF Tank Capacity	gal./liters		7.4 x 2/28 x 2	
	Lubricant Volume	gal./liters		10.5/40	
	Cooling Water Volume	gal./liters		8.7/33	
Starting Motor Capacity	V-kW		24-5		
Charging Alternator Capacity	V-A		24-50		
Battery Capacity	V-Ah		12-100		
Unit	Length	in./mm		143.7/3,650	
	Width	in./mm		52.8/1,340	
	Height	in./mm		87.8/2,230	
	Dry Weight	lbs./kg		9,370/4,250	
	Net Weight	lbs./kg		11,730/5,320	

*1: Output in the brackets shows when the selector switch is set at 480V.

2-2. Ambient Conditions

Use this generator in ambient conditions as described below. Failure to provide these conditions can result in problems such as malfunction, insufficient output and reduced durability.

- Ambient temperature: 5 to 104 °F (-15 to 40 °C)
- Relative humidity: 85% or less
- Altitude: 984 ft. (300 m) or less

3. Applications

- Power source for submerged pumps and similar civil engineering equipment
- Power source for lighting and similar equipment
- Power source for electrical tools and household appliances



CAUTION : PROPERTY/SECONDARY DAMAGE

- Do not use for any application other than those listed above.
- If using this generator for medical equipment, check before use with the medical equipment manufacturer, doctor, hospital or similar entity.

4. Part Names

4-1. External View/Part Names

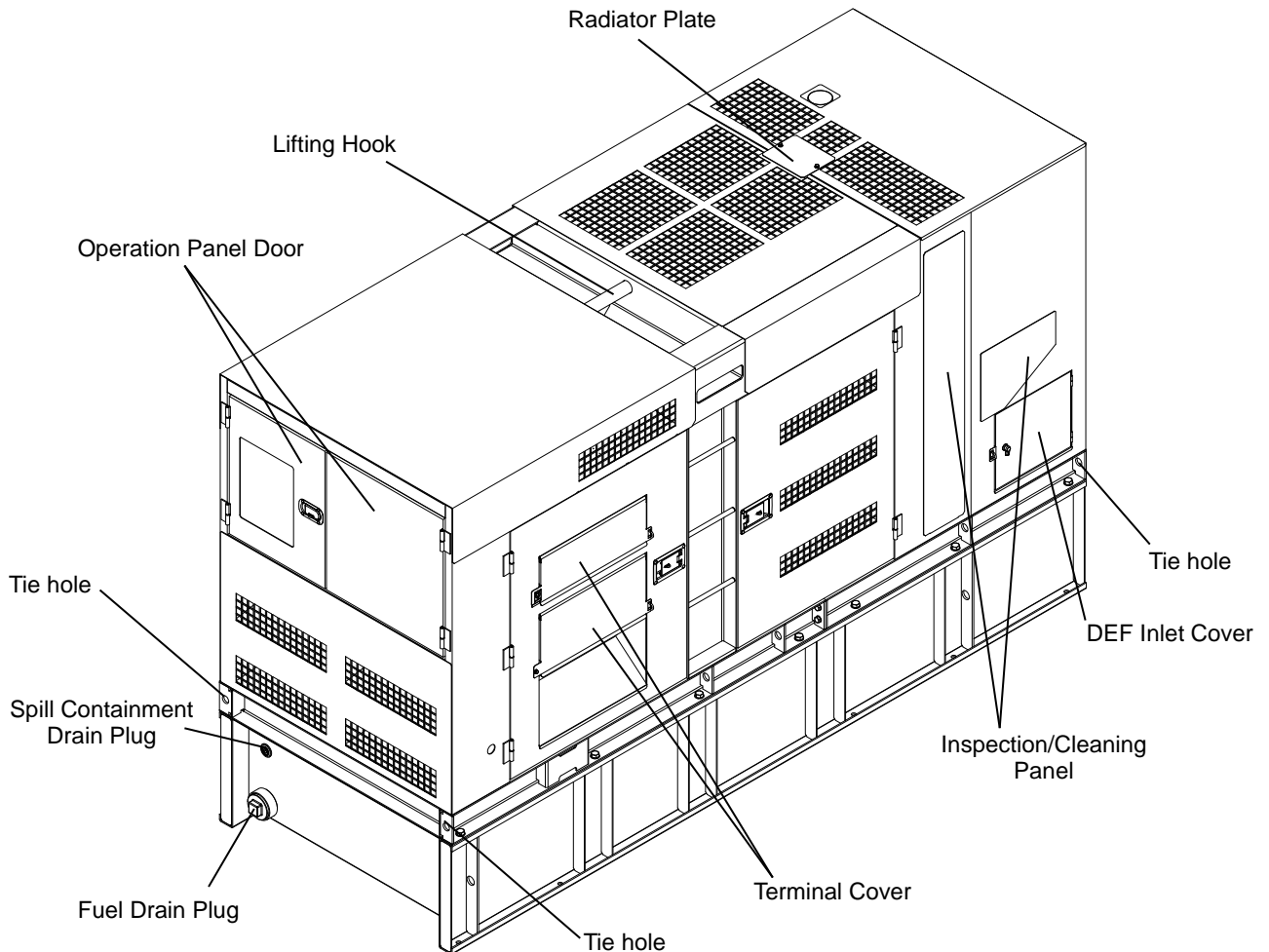

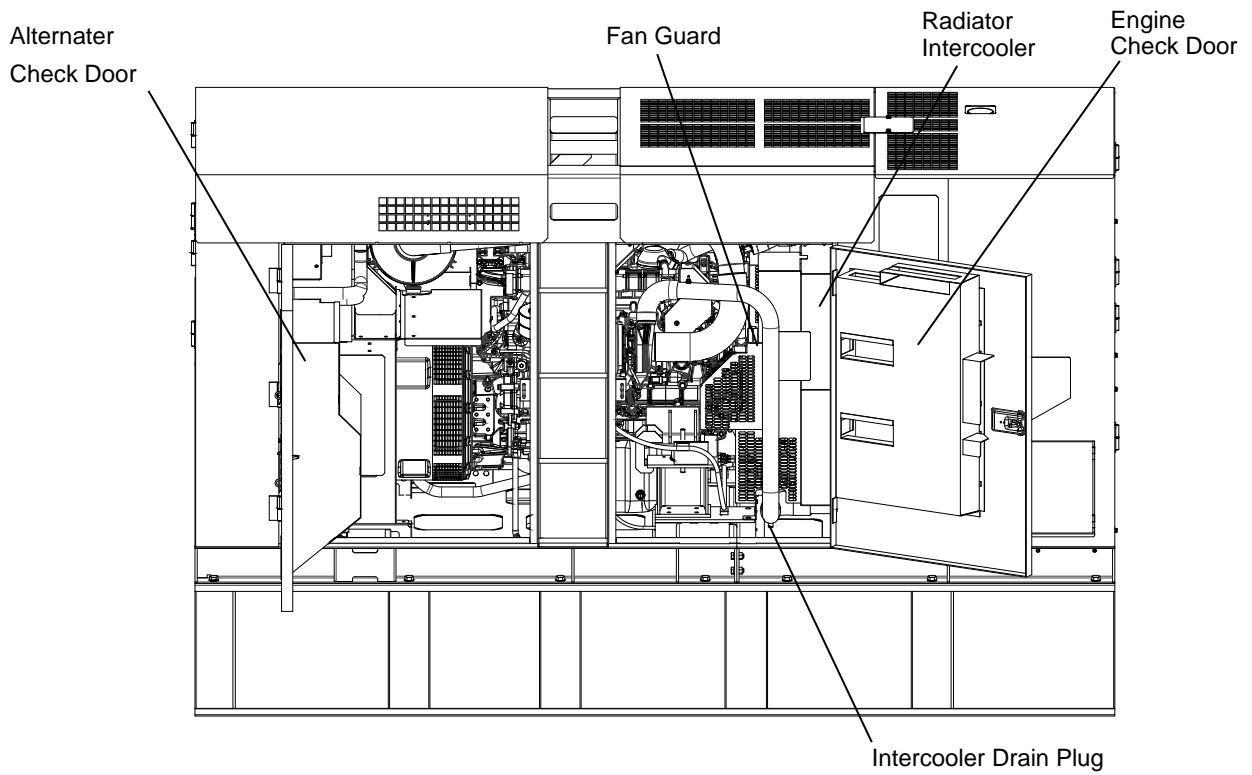
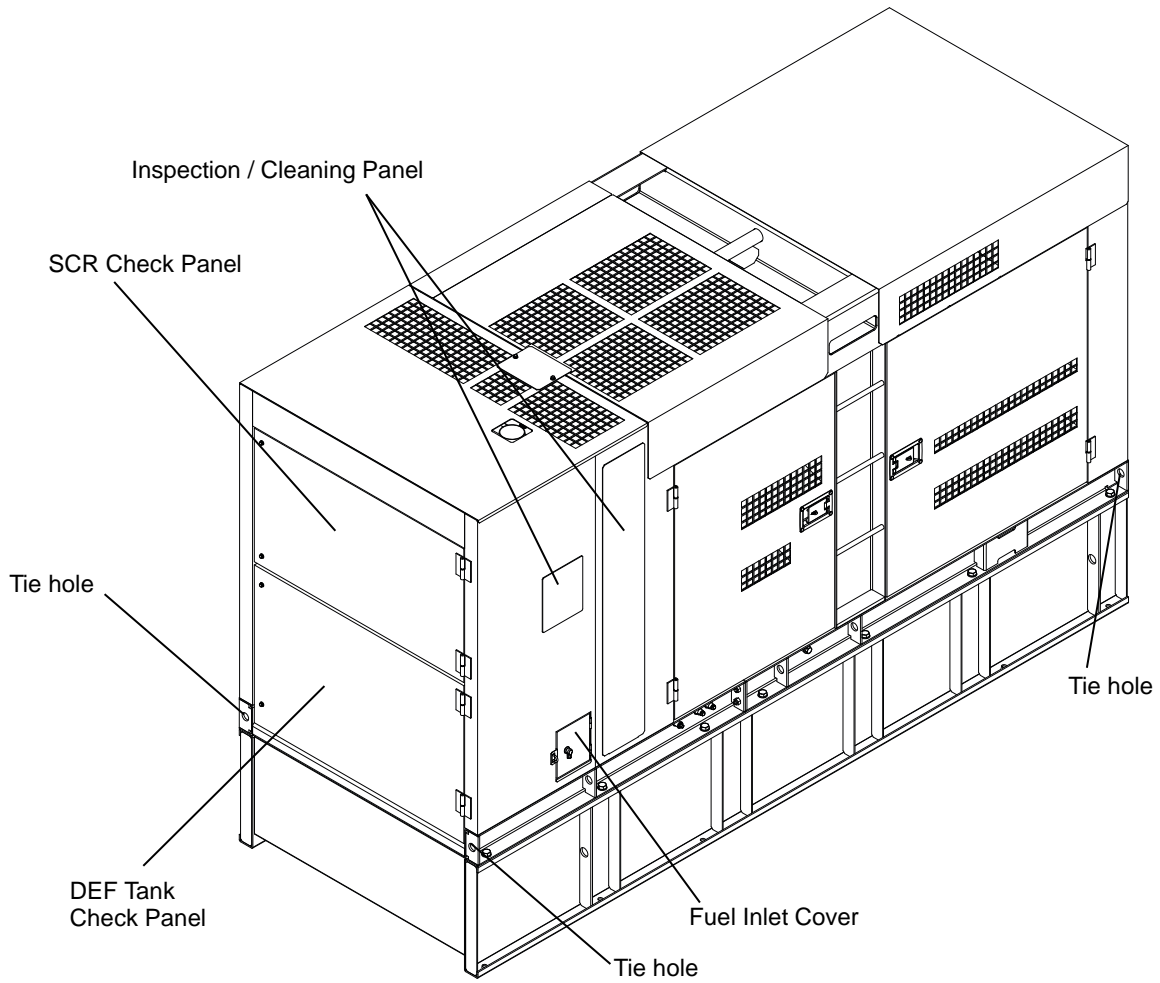

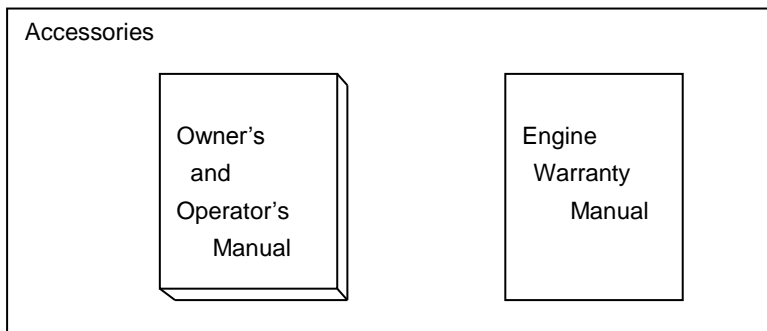
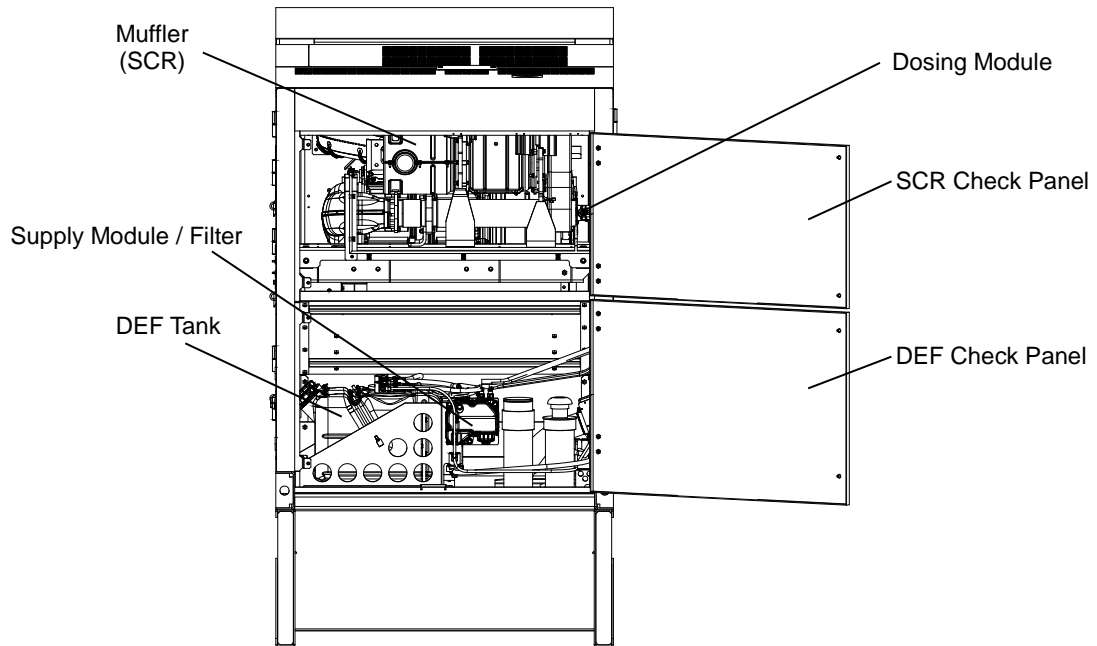
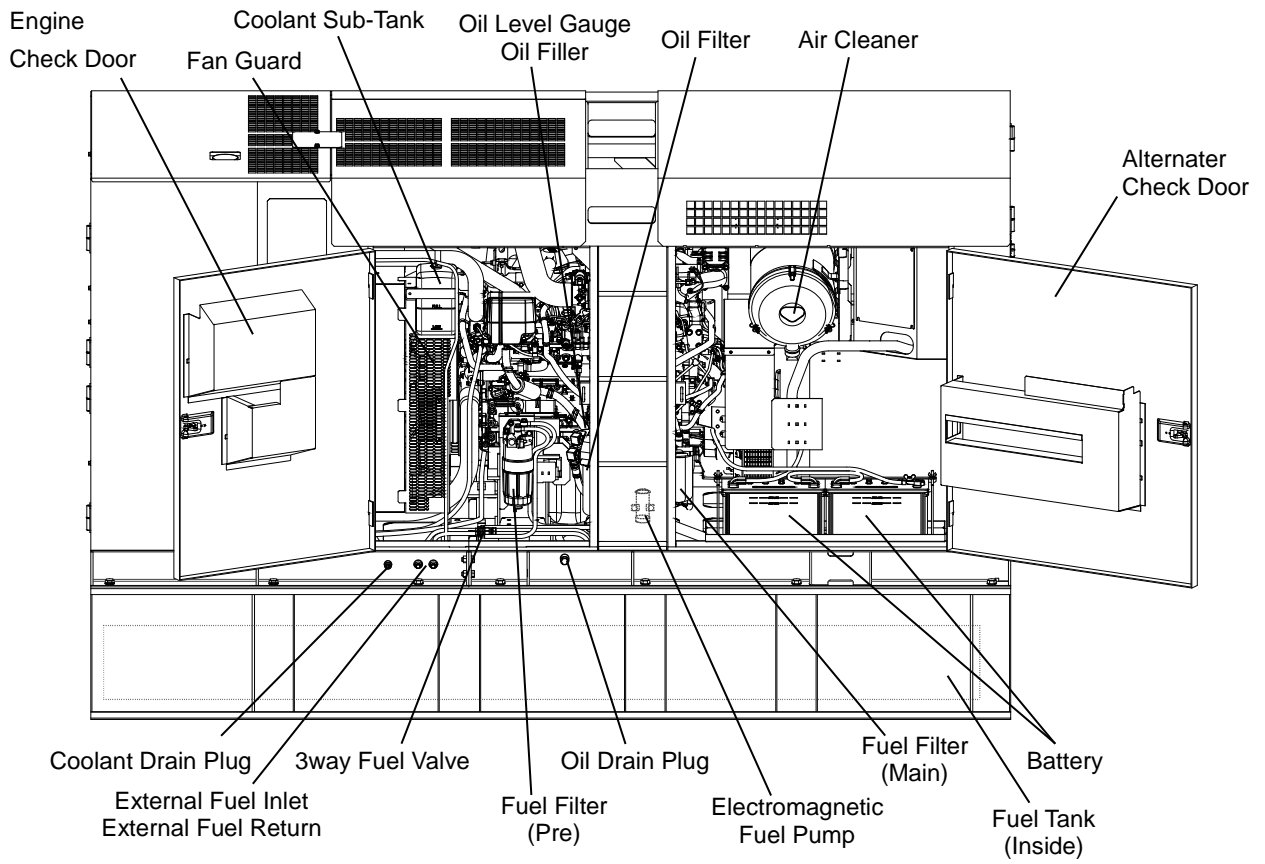

4-2. Operation Panel Configuration

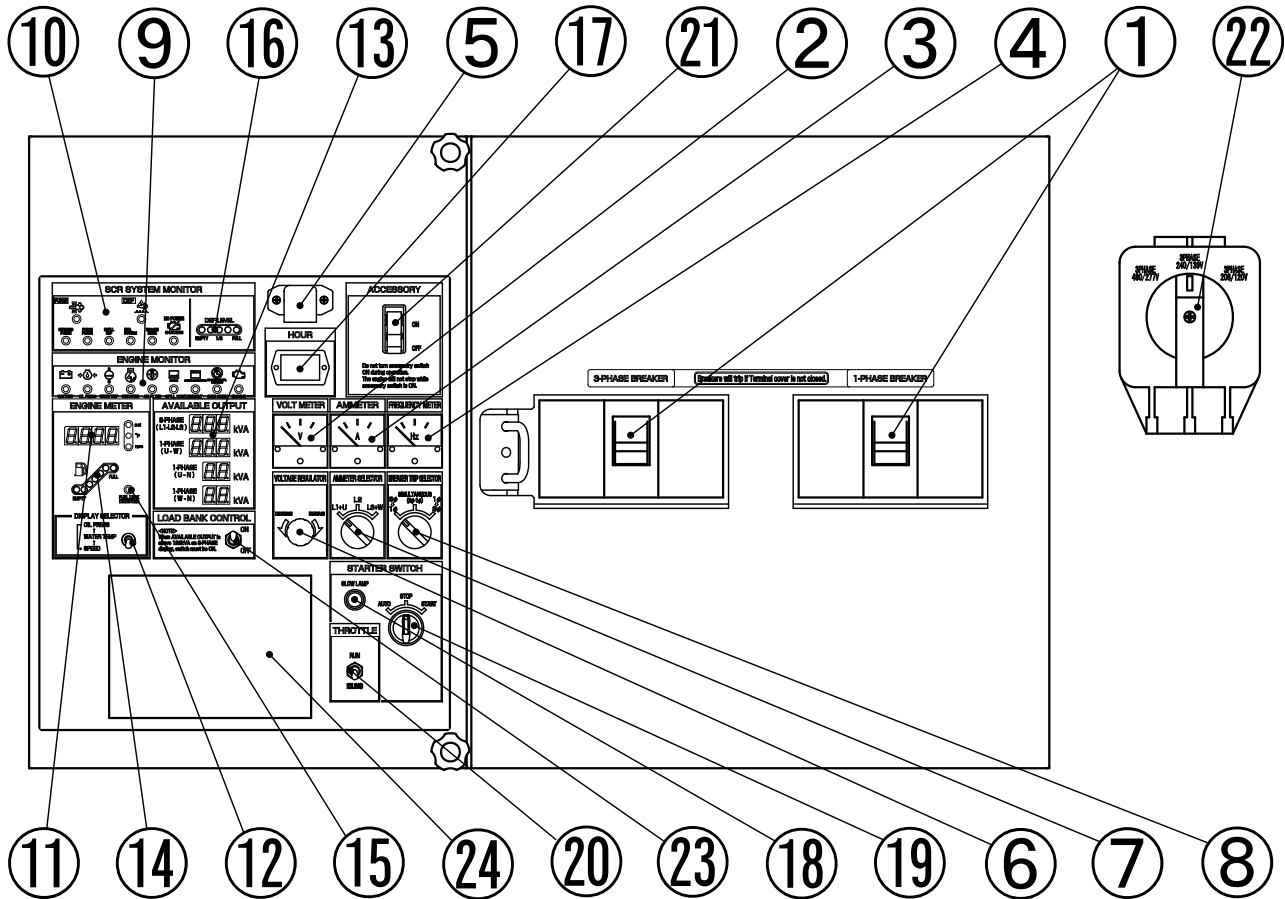

①	Circuit Breaker(3-Phase & 1-Phase)	⑬	Available Output Monitor
②	Voltmeter	⑭	Fuel Level
③	Ammeter	⑮	Fuel Leak Detected Lamp
④	Frequency Meter	⑯	DEF Level
⑤	Pilot Lamp	⑰	Hour Meter
⑥	Voltage Regulator	⑱	Glow Lamp
⑦	Ammeter Selector Switch	⑲	Starter Switch
⑧	Breaker Trip Selector Switch	⑳	Throttle Switch
⑨	Warning Indicators	㉑	Accessory Switch
⑩	SCR Indicators	㉒	Voltage Selector Switch
⑪	Oil Pressure / Water Temperature / Speed Monitor	㉓	Load Bank Control Switch
⑫	Oil Pressure / Water Temperature / Speed Selector Switch	㉔	Auto start Panel (Optional)

5. Equipment

5-1. Three-phase and Single-phase simultaneous Output

This generator is capable of generating three-phase and single-phase three-wire output simultaneously. (Three-phase output terminal and single-phase three-wire output terminal are equipped individually.)

Neither switching operation of output nor switching operation of wiring is needed.

Three-Phase and Single-Phase Three-Wire Output Terminal

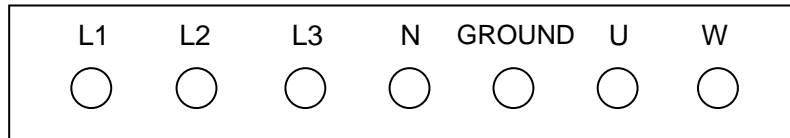

< Note >

- Refer to section “7-2. Connecting Load Cables” for Load Connections.
- If using three-phase output simultaneously with a single-phase three-wire type output, use in a range where the total current does not exceed the rated current.

5-2. Available Output Monitor

The available generated output for each output power source is displayed digitally.

< Note >

- Consider the digitally displayed available output as an approximate estimate. Be sure to thoroughly consider the displayed value and the used load capacity when using a load such as a motor with large starting capacity.
- The displayed output capacity might not be correct values if using a four-wire connection (single-phase using the N terminal) for a three-phase output power source. Connect to a single-phase/three-line type power source if using a single-phase power source.
- If “- -” is displayed for the available output, it means that usage has exceeded the rated capacity. Immediately stop the equipment being used and reduce the load capacity of the equipment.

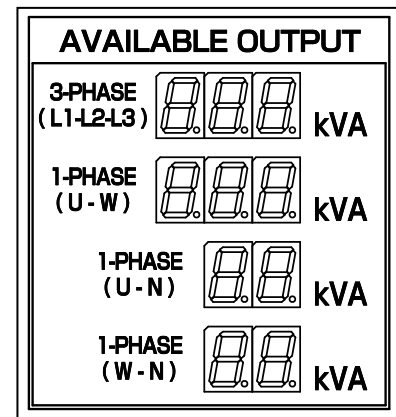

5-3. Spill Containment



WARNING : INJURY



- Do not open the check door when the starter switch is in the AUTO or START position. It will cause injury by rotating parts such as cooling fans and fan belt.
- Always turn the starter switch to the STOP position and stop the engine, then close and lock OPERATION PANEL DOOR before checking or maintaining the engine or any equipment.



CAUTION : BURNS



- Do not touch the engine and surrounding components immediately after stopping the engine as they are still extremely hot.



CAUTION : FIRE



- If fuel or oil is leaking, repair the leaking location before operating.

The bed of this generator is equipped with the spill containment (structure for preventing leakage of liquid) so that any spilled liquid will not leak to outside of the generator when oil or fuel is spilled or leak. Before starting operation, check if there is accumulated liquid in the spill containment. Flush out any liquid that has accumulated.

(Refer to section “**8-6. Checking the Spill Containment**” for inspection procedures.)

(Refer to section “**10. Inspection/Maintenance (15) Flushing Liquid in Spill Containment**” for flushing procedures.)

The generator is equipped with the following in order to prevent liquid from spilling in case you forget to flush the liquid: The operation panel is equipped with the SPILL CONTAINMENT CHECKING indicator that illuminates when its sensor is triggered as the spill containment capacity accumulated enough liquid to reach to about 33gal (125 liters).

If the liquid stored in the spill containment exceeds approximately about 55gal (208 liters) during operation, the SPILL CONTAINMENT OVERFLOW WARNING indicator illuminates, and the engine will be automatically stopped. If this occurs, flush the liquid stored in the spill containment.

(Refer to section “**10. Inspection/Maintenance (15) Flushing Liquid in Spill Containment**”.)

< Note >

- Water can also accumulate in the spill containment due to rain entering into the generator. Accordingly, you should periodically flush liquid accumulated within the generator. However, you should flush water according to the frequency/amount of rainfall.
- The types of liquids that can accumulate in the spill containment include oil, fuel, coolant, battery fluid and DEF such that it is not possible to distinguish between rainwater and other liquids. Dispose of flushed liquids according to the applicable laws and regulations.

5-4. Warning Indicators



- Do not open the check door when the starter switch is in the AUTO or START position. It will cause injury by rotating parts such as cooling fans and fan belt.
- Always turn the starter switch to the STOP position and stop the engine, then close and lock OPERATION PANEL DOOR before checking or maintaining the engine or any equipment.



- Do not touch the engine and surrounding components immediately after stopping the engine as they are still extremely hot.

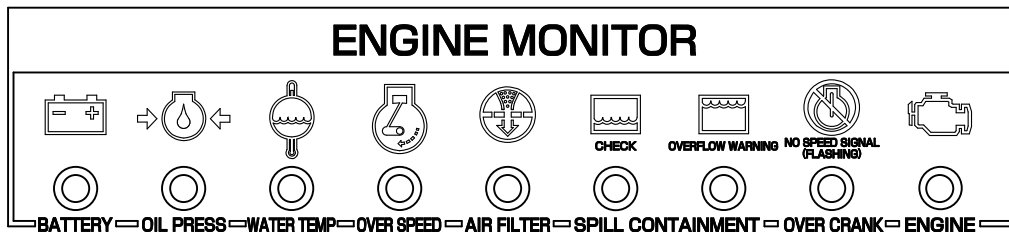

This generator is equipped with the following warning indicators: BATTERY (battery charge), OIL PRESS (engine oil pressure), WATER TEMP (coolant temperature), OVER SPEED (engine overspeed), AIR FILTER (air cleaner clogging), SPILL CONTAINMENT (spill containment amount), OVER CRANK (engine fails to start), and ENGINE (engine malfunction). When the engine starts, all the lamps will be lights off. An indicator illuminates if a malfunction/fault occurs during operation and the engine automatically stops depending on the fault type. Selecting the starter switch from STOP to START position causes the BATTERY warning indicator to illuminates and ENGINE for warning indicator to illuminates approximately 3 sec.

(1) BATTERY (Battery Charge) Warning Indicator (Low Battery Voltage)

The BATTERY warning indicator illuminates when charging is not possible during operation. If this occurs, contact authorized distributor where the generator was purchased.

< Note >

- This battery charging warning indicator cannot detect battery deterioration or insufficient battery fluid. (Refer to section “8-8. Checking the Battery”.)

(2) OIL PRESS (Engine Oil Pressure) Warning Indicator (Low Oil Press.)



- Always be sure to stop the engine and allow the engine to cool when performing inspection or maintenance of engine oil. Opening the oil gauge or oil filler cap during operation will result in hot oil gushing out.

If the engine oil pressure drops below 7 psi (0.48 x100 kPa) during operation, the OIL PRESS warning indicators illuminates, and the engine will be automatically stopped.If this occurs, check the engine oil level and add engine oil until it reaches the maximum level.

< Note >

- This oil pressure warning indicator cannot detect oil deterioration. Change the engine oil periodically. (Refer to section “8-1. Checking Engine Oil”.)

(3) WATER TEMP (Coolant Temperature) Warning Indicator (High Water Temp.)



CAUTION: BURNS



- Do not open the radiator cap immediately after stopping the engine. Do so will result in hot steam gushing out.
- Hot steam gushes out from the coolant sub-tank if the generator overheats. Do not touch the coolant sub-tank.

If the coolant temperature rises above 212°F(100°C) during operation, the WATER TEMP warning indicators illuminates, and the engine will be automatically stopped. If this occurs, hot steam will gush out of the coolant sub-tank. Check the coolant sub-tank coolant level after the generator cools and add coolant to the coolant sub-tank if it is insufficient. (Refer to section “**8-2. Checking Coolant**”.) If the coolant is at the specified amount, it is probable that the fan belt is loose or there is a coolant leak. Wait for the engine to cool down and inspect for these problems.

< Note >

- The coolant temperature cannot be detected if the coolant level is excessively low. Always be sure to check the coolant level in the radiator coolant sub-tank before starting operation.

(4) OVER SPEED (Engine Overspeed) Warning Indicator

This generator is equipped with a function such that the engine is automatically stopped if an engine fault occurs causing the engine speed to increase excessively. If the engine speed rose above 2070rpm during operation, the OVER SPEED warning indicators and ENGINE warning indicators illuminates, and the engine will be automatically stopped. If this occurs, it is probable that some malfunction has occurred in the engine. Contact authorized distributor where the generator was purchased.

(5) AIR FILTER (Air Cleaner Clogging) Warning Indicator

The AIR FILTER warning indicator illuminates if the air cleaner element becomes clogged during operation. If it illuminates, immediately stop the engine and clean or replace the air cleaner element.

(Refer to section “**10. Inspection/Maintenance (4) Air Filter Element Cleaning/Replacement**”.)

(6) SPILL CONTAINMENT (Spill Containment Amount) Checking Indicator

The SPILL CONTAINMENT checking indicator illuminates if the liquid stored in the spill containment exceeds approximately about 33gal (125 liters) during operation. If it illuminates, immediately stop the engine and flush the liquid stored in the spill containment.

(Refer to section “**10. Inspection/Maintenance (15) Flushing Liquid in Spill Containment**”.)

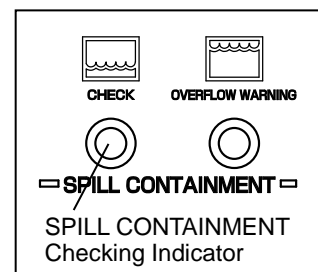

< Note >

- The engine may not be stopped only if the spill containment checking Indicator illuminates during operation.
- When the spill containment checking Indicator illuminates during operation, stop the engine, check for fuel, oil, cooling water and DEF leakage, and repair as necessary.
- Do not use the equipment with liquid accumulated in the spill containment. Drain the spill containment before using.

(7) SPILL CONTAINMENT (Spill Containment Amount) Overflow Warning Indicator

If the liquid stored in the spill containment exceeds approximately about 55gal (208 liters) during operation, the SPILL CONTAINMENT overflow warning indicator illuminates, and the engine automatically stops. If this occurs, flush the liquid stored in the spill containment. (Refer to section "10. Inspection/Maintenance (15) Flushing Liquid in Spill Containment".)

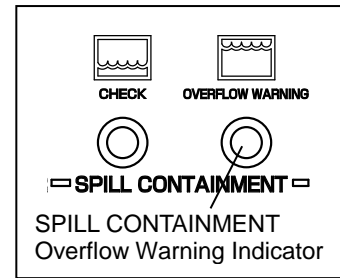

< Note >

- Although the fluids that can leak internally consist of oil, fuel, cooling water and DEF, the spill containment does not have a function that can separate rainwater that has leaked into the equipment from these internally leaked fluids. Properly dispose of liquid drained from the spill containment in a manner according to the applicable laws and regulations.

(8) Over Crank / No Speed Signal Indicator

This indicator illuminates if the engine fails to start. If that happens, set the "STARTER SWITCH" selector to STOP, and inspect the machine. (Refer to section "12. Troubleshooting.") If this indicator starts flashing, the rotation signal has not been detected correctly. Contact the authorized distributor where the generator was purchased.

(9) ENGINE (Engine Malfunction) Warning Indicator

The ENGINE warning indicator illuminates if the coolant temperature is high, the oil pressure is low, the engine overspeeds, the battery voltage is low or some other engine fault occurs during operation. If this occurs, a malfunction code is displayed on the engine and available output monitors, and the engine automatically stops or the engine output is reduced.

If the ENGINE warning indicator illuminates, contact the authorized distributor where the generator was purchased.

5-5. SCR (Selective Catalytic Reduction) System and Indicators

WARNING : INJURY

- Do not open the check door when the starter switch is in the AUTO or START position. It will cause injury by rotating parts such as cooling fans and fan belt.
- Always turn the starter switch to the STOP position and stop the engine, then close and lock OPERATION PANEL DOOR before checking or maintaining the engine or any equipment.

CAUTION : BURNS

- Do not touch the engine and surrounding components immediately after stopping the engine as they are still extremely hot.
- While the engine is running, the SCR system is purging, and immediately after operating, the SCR system and exhaust piping is extremely hot. Be careful not to inadvertently touch them.

In order to meet requirements set forth by EPA Tier4 (Final), the SCR system is equipped to reduce nitrogen oxides (NOx) in exhaust emissions, and Diesel Exhaust Fluid (DEF) is used as a reducing agent.

Use DEF that is compliant with the ISO (International Organization for Standardization) 22241 standard defined for AUS 32, or the API (American Petroleum Institute) standards.

- DEF, or other similar urea fluids, may be called AdBlue[®] depending on region.
- AdBlue[®] is a registered trademark of Verband der Automobilindustrie (VDA).

This generator is equipped with the SCR SYSTEM MONITOR.

The indicator lights up according to the control operation of the SCR system.

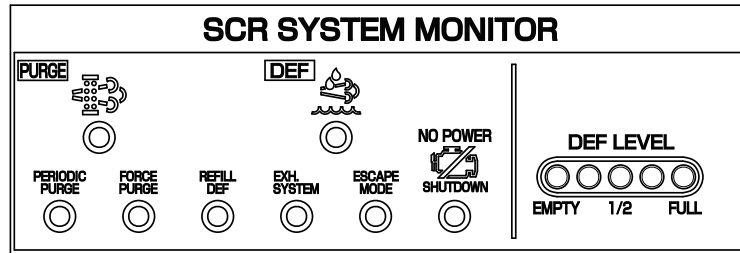

(1) DEF LEVEL

It shows the amount of DEF in the tank.

All lamps are lit when the amount reaches to the maximum level, and FULL is lit.

The lit lamp decreases as the amount of DEF in the tank reaches to EMPTY.

< Note >

- The engine will shut down upon DEF gets empty.
- When replenishing diesel fuel, check the amount of DEF in the tank, and replenish DEF as necessary.

■ DEF LEVEL Lamp Action

DEF remaining amount \ LAMP	DEF LEVEL	DEF	REFILL DEF	NO POWER (SHUTDOWN)	ESCAPE MODE
Less than 100% More than 75%	All Lamp Turn ON	—	—	—	—
Less than 75% More than 50%	4 Lamp Turn ON	—	—	—	—
Less than 50% More than 25%	3 Lamp Turn ON	—	—	—	—
Less than 25% More than 10%	2 Lamp Turn ON	—	—	—	—
Less than 10% More than 5%	1 Lamp Turn ON	○ (Turn ON)	○ (Turn ON)	—	—
Less than 10% More than 0%	1 Lamp Slow Blinking	○ (Slow Blinking)	○ (Turn ON)	—	—
0% (EMPTY)	All Lamp Slow Blinking	○ (Quick Blinking)	○ (Turn ON)	○ (Turn ON)	—
0% (ESCAPE MODE)	All Lamp Slow Blinking	○ (Quick Blinking)	○ (Turn ON)	—	○ (Turn ON)

(2) PURGE Indicator

After certain length of operation time, SCR system automatically increase the temperature of the exhaust gas, and purges inside the system, thereby maintaining the system function.

This lamp is lit up during purging.

○ PERIODIC PURGE

Purge runs automatically after certain period of operating time. PERIODIC PURGE is lit during operation.

○ **FORCE PURGE**

Purge forcibly runs in case that PERIODIC PURGE fails twice. FORCE PURGE is lit during operation.

< **Note** >

- During purging, electrical output capacity decreases to 80% of the rated output. Available output capacity can be confirmed by Available Output Monitor.
- FORCE PURGE failure does not stop the engine. Instead, the engine warning lamp will be lit. In this case, contact distributor or dealer and ask for repair.
- White smoke may be temporarily seen from the tailpipe during purging, but it is not a sign of malfunction.
- Smell of ammonia may be noticed during purging, but it is not a sign of malfunction.
- Abnormal noise can be heard during purging, but it is not a sign of malfunction.

■ **SCR System Purge Lamp Action**

MODE \ LAMP	PURGE	PERIODIC PURGE	FORCE PURGE
PERIODIC PURGE	○ (Turn ON)	○ (Turn ON)	—
FORCE PURGE	○ (Turn ON)	—	○ (Turn ON)

(3) DEF Indicator

This lamp is lit or starts blinking to alert an error relating to SCR system which includes shortfall of DEF, using DEF of low-quality, or disconnection of sensors.

Warning status ranges from stage- I to stage-III. The engine will shut down at stage-3. In this case, conduct inspection and repair immediately.

However, in case that you need restart the engine for unavoidable reasons, ESCAPE MODE allows you to restart the engine for total time up to 30 minutes.

○ **REFILL DEF**

It is lit when the amount of DEF decreases to 10% or less.
Replenish DEF when it is lit.

○ **EXH. SYSTEM**

It lights up when abnormality of SCR System is detected.
Please contact distributor or dealer for repair.

○ **ESCAPE MODE**

It is lit when ESCAPE MODE is engaged.
(Refer to section "5-5. (4) Operating Escape Mode")

○ **NO POWER (SHUTDOWN)**

It is lit when the engine stops due to DEF shortfall or SCR system error.
Contact the authorized distributor where the generator was purchased.

■ DEF Indicator Lamp Action

State \ LAMP	DEF	EXH. SYSTEM	NO POWER (SHUTDOWN)	ENGINE	ESCAPE MODE
Stage- I Warning	○ (Turn ON)	○ (Turn ON)	—	○ (Turn ON)	—
Stage- II Early Inducement	○ (Slow Blinking)	○ (Turn ON)	—	○ (Turn ON)	—
Stage- III Final Inducement (Engine Shutdown)	○ (Quick Blinking)	○ (Turn ON)	○ (Turn ON)	○ (Turn ON)	—
ESCAPE MODE	○ (Quick Blinking)	○ (Turn ON)	—	○ (Turn ON)	○ (Turn ON)

(4) Operating Escape Mode

This mode allows you to restart the engine that forcibly shut down due to DEF shortage or SCR system error.

A total of 30 minutes of time operation is possible for urgent needs.

- 1 Set the ACCESSORY switch to ON position.
- 2 Loosen the knob on the operation panel and open the panel.
- 3 Press the Escape Mode switch (blue button) in the control box. (Make sure that the escape mode lamp is lit.)
- 4 Close the operation panel and tighten the knob.
- 5 Set the ACCESSORY switch to OFF, and use the safety cap to cover it.
- 6 Set the STARTER SWITCH selector to START position.

< Note >

- ESCAPE MODE is available for total up to 30 minutes. On and after 30 minutes, the procedure above described is never applicable, and the engine never restarts.
- Upon completing repair during ESCAPE MODE, it automatically switches back to the normal mode.

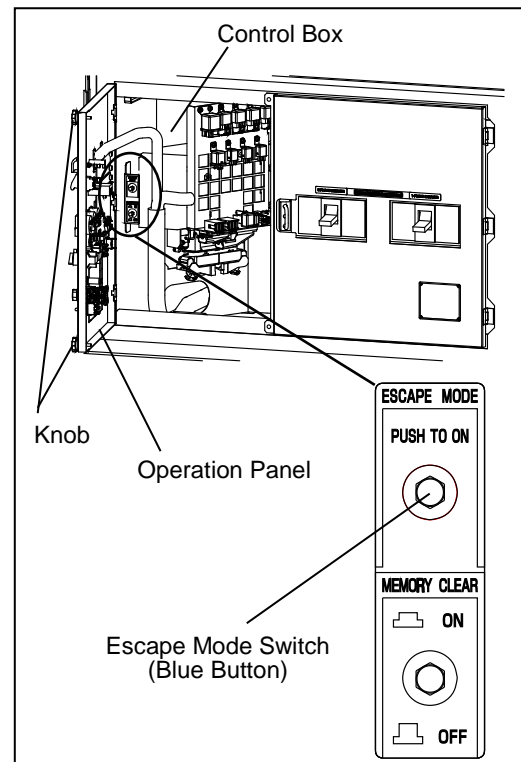

5-6. Meters and Gauges

Engine Meters and Gauges

(1) Hour Meter

Displays the operating time. Use this as a reference for managing periodic inspection interval. Be careful as the hour meter operates when the ACCESSORY switch is at ON position regardless of engine is running or not, and / or when the engine shuts off abnormally when STARTER SWITCH is set at START position or AUTO position (Except when Over Crank Indicator illuminate or flashing).

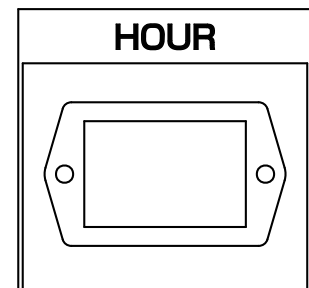

(2) Oil Pressure / Water Temp / Speed Monitor

Displays the engine speed, water temperature and oil pressure. Switching the selector switch changes the display in the following order: Speed → Water temp → Oil press. Engine speed is displayed first when the engine is started.

○ Speed

Displays the engine speed. 1800rpm is displayed at 60 Hz.

○ Water Temp

Displays the temperature of the engine coolant. Normal temperature displayed during operation should generally between 167°F (75°C) and 194°F (90°C) depending on usage.

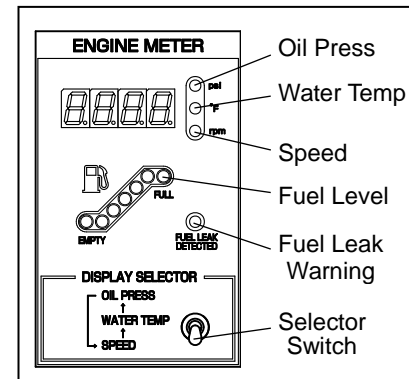

< Note >

- If the coolant temperature rises above 212 °F(100°C), immediately stop all connected equipment to the generator, and idle the engine while cool down the coolant temperature.

○ Oil Press

Displays the pressure of the engine lubrication system. Normal pressure displayed during operation should generally between 42 and 71 psi (2.90 – 4.90 x 100 kPa) depending on usage. However, the pressure may rise above this range just after starting a cold engine. Idle the engine until it reaches the normal pressure.

(3) Fuel Level

It shows the amount of fuel in the tank.

All lamps are lit when the amount reaches to the maximum level, and FULL is lit.

The lit lamp decreases as the amount of fuel in the tank reaches to EMPTY.

The fuel level on the control panel will only display the fuel level for the internal fuel tank.

(4) Fuel Leak Warning Indicator

Fuel Leak Warning Indicator illuminates if the Fuel stored in the fuel tank leaked. If it illuminates, immediately stop the engine please contact distributor or dealer for repair.

< Note >

- When the fuel leak warning Indicator illuminates during operation, stop the engine, check for fuel, oil, cooling water and DEF leakage, and repair as necessary.

- Do not use the equipment with liquid accumulated in the spill containment. Drain the spill containment before operation.

Generator Meters and Gauges

(1) Voltmeter

The voltmeter displays the three-phase output voltage (voltage between L1-L3). Check that 240 V is displayed during operation. Output voltage for single-phase three-wire (voltage between U-W) is the same voltage as the three-phase output voltage (voltage between L1-L3). Accordingly, use the voltage meter displayed value as a reference.

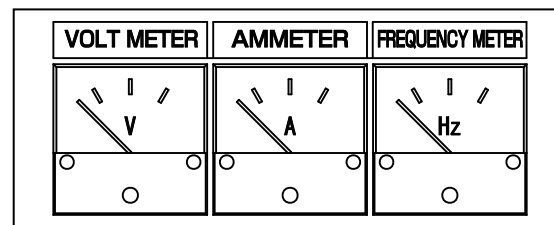

* Check that 208 V is displayed during operation if using at the three-phase 208 V setting. Check that 480 V is displayed during operation if using at the three-phase 480 V setting. The voltage of single-phase three-wire output of “U-W Voltage” is a value that is one half of the displayed voltage meter value.

(2) Ammeter

Displays the output current (phase current) of the generator. Turn the ammeter selector switch to “L1+U” to display the output current of the three-phase L1 phase and single-phase U phase. Turn the switch to “L3+W” to display the output current of the three-phase L3 phase and single-phase W phase. “L2” displays the output current of three-phase output terminal L2.

< Note >

- If measuring the output current for a single-phase three-wire type, turn the ammeter selector switch to “L1+U” or “L3+W”. The voltage cannot be accurately measured if set to “L2”.

(3) Frequency Meter

Displays the frequency of the power source. Check that 60 Hz is displayed during operation.

Indicators

(1) Glow Lamp

This lamp illuminates when the starter switch is on START position. This lamp turns off when pre-heating is completed. This lamp turns off and the generator starts.

< Note >

- Pre-heating time depends on the coolant temperature, and should be completed in approximately 0 to 16 sec.

(2) Pilot Lamp

This lamp illuminates when the engine is operating to indicate that power is being generated.

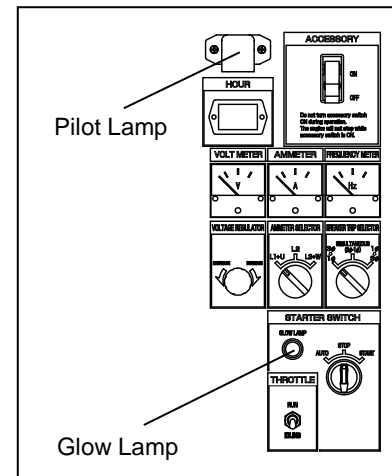

Switches

(1) Starter Switch

The engine warms up and starts automatically.

① START

The engine is started in this position.

The engine warms up and starts automatically.

② STOP

The engine is stopped, and the power supply is turned off completely in this position. You can operate the ACCESSORY switch in this position.

③ AUTO

The engine is started in this position when the REMOTE START terminal closes.

(2) Accessory Switch

If you select ON, the display turns on, activate the electromagnetic pump, you can check the fuel level and you can bleed air from the fuel system.

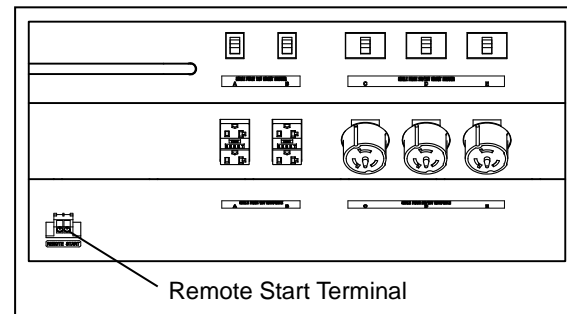
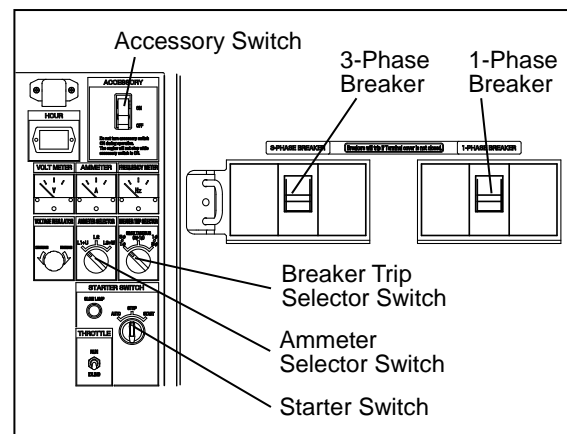

< Note >

- Set the STARTER SWITCH selector to STOP to activate this function.
- Do not leave the ACCESSORY switch at ON position. This is causing battery from drain out.

(3) Breaker

This switch is for transmitting electrical power to the load side. Turn to ON position to output voltage to the output terminals. Output to the load side is cut off when there is a short circuit or overload on the load side.

< Note >

- Do not turns off/on the breaker manually to operate or stop a load.

(4) Breaker Trip Selector Switch

This switch is for selecting the tripping order of the three-phase and single-phase breaker when there is a short circuit or overload on the load side. If the three-phase or single-phase breaker is selected for precedence in tripping, the selected breaker will trip first when the total generator output exceeds the rated capacity.

After that, the other breaker will also trip if the generator output exceeds the rated capacity again.

• Switch Selection

- “ $3\phi \Rightarrow 1\phi$ ”: The three-phase breaker trips first followed by the single-phase breaker.
- “Simultaneous ($3\phi \cdot 1\phi$)”: The three-phase and single-phase breakers trip simultaneously.
- “ $1\phi \Rightarrow 3\phi$ ”: The single-phase breaker trips first followed by the three-phase breaker.

(5) Ammeter Selector Switch

This switch is for selecting the output current indicated by the ammeter. Change the switch to display the following output terminal current on the ammeter.

• Switch Selection

- “L1+U”: Three-phase L1 phase + Single-phase three-wire U phase (total)
- “L2”: Three-phase L2 phase
- “L3+W”: Three-phase L3 phase + Single-phase three-wire W phase (total)

< Note >

- If measuring the output current for a single-phase three-wire type, turn the ammeter selector switch to “L1+U” or “L3+W”. The voltage cannot be accurately measured if set to “L2”.

Voltage Regulator/Throttle Switch

(1) Voltage Regulator

This dial is for regulating voltage output by the generator. Turn the dial clockwise to increase the voltage and counterclockwise to decrease it.

(2) Throttle Switch

This switch is for changing the engine speed. Set to IDLING when starting, warming up and cool down the engine, and set to RUN during rated operation.

< Note >

- The engine is running at 1800rpm with 60Hz regardless of throttle switch position if you leave starter switch in AUTO position.

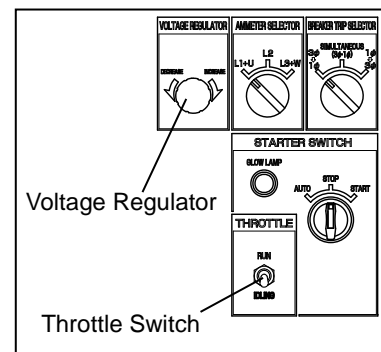

5-7. Fuel Piping Switch (3Way Fuel Valve)

CAUTION : FIRE

- Always make sure that the engine is stopped when working on piping.
- Always be sure to wipe up any spilled fuel.
- After working on the piping, check that there is no fuel leakage.

Change the three-way fuel valve to switch to supply fuel from the external tank. In that case, the internal fuel tank will not be used.

(1) If using the internal fuel tank

Change the lever of the three-way fuel valve turned to the “B” side to supply fuel from the internal tank. It is turned to the “B” side when the generator is shipped from the factory.

< Note >

- When disconnecting piping from the external tank, turn the lever to the “B” side, and attach the bundled plug (R1/2”) to the external tank fuel inlet / return.

(2) If using an external fuel tank

Connect hoses from the external fuel tank to the external fuel inlet and the external fuel return. Change the lever of the 3way fuel valve to the “A” side to supply fuel from the external tank. Refer to “9-6. Connecting with External Fuel Tank” for corresponding procedures.

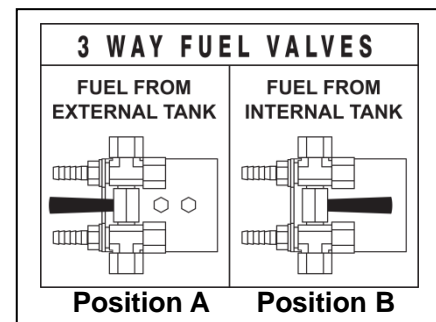
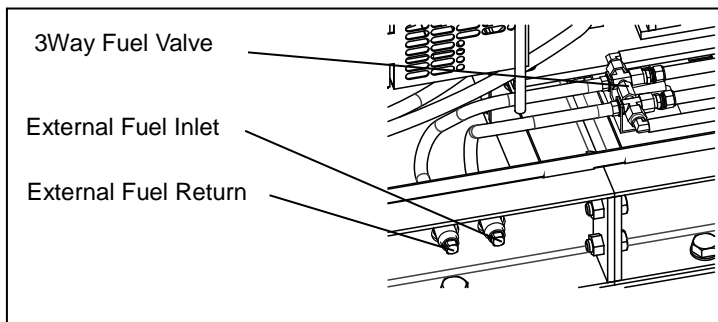

5-8. Load Bank Control Switch

This equipment is adopted Load Bank Control Switch to improve carbon debris in a muffler or extreme light load rated load.

To activate this function, turn ON the Load Bank Control Switch on the control panel.

< Note >

- Select Load Bank Switch to ON position when remaining three phase output indicator is displaying more than 126kVA.

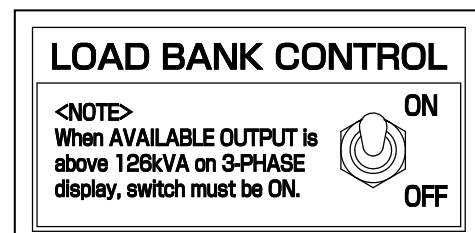

6. Transport/Installation

6-1. Transport Procedures

WARNING : INJURY

- Always be sure to use lifting hooks when lifting up the generator. The other thing could result in the generator falling.
- No persons should ever be under a lifted generator.

CAUTION : INJURY

- Always be sure to use lifting hooks when lifting up the generator, and raise it slowly at a completely vertical angle.
- Personnel performing lifting work must wear protective gear such as helmets, safety shoes and gloves.
- Do not move the generator during operation.

(1) Lifting Procedures

Always be sure to use lifting hooks when lifting up the generator, and raise it slowly at a completely vertical angle.

(2) Transport

When transporting this generator, tie rope to the left and right tie holes, and securely fix the generator.

< Note >

- Handle this generator with great care when raising, lowering and transporting. Rough handling of generator can result in damage or malfunction.

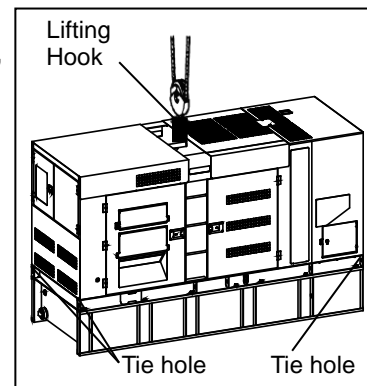

6-2. Installation Procedures

WARNING : EXHAUST GAS POISONING

- Do not operate the generator in poorly ventilated areas such as indoors or tunnels, as the exhaust gas of the engine contains substances that are harmful to human health.
- Do not direct exhaust fumes at bystanders or buildings.

CAUTION : FIRE

- Do not carry flammable items (such as fuel, gas and paint) or items that are highly combustible near the generator as the muffler, exhaust gas and other parts become extremely hot.
- Operate this generator 3 ft. (1 m) or more from walls or other hindrances, and on a level surface.
- Do not connect the generator output to indoor wiring.

- If installing this generator, set up barriers or fencing completely around the boundary line of the construction area and take measures to prevent persons not involved in the construction from entering the area.

- Position this generator on a hard, flat and leveled surface.
- Position this generator 3 ft. (1 m) or more from walls or other hindrances so that the operation panel door and left/right check doors are accessible for internal inspection/maintenance.

< Note >

- This generator is manufactured presupposing that it will be installed on a flat, hard and leveled surface. Accordingly, care must be taken as using under any other installation conditions can result in a fault or malfunction.
- Do not place any objects where they will interfere with the radiator or muffler exhaust ports. Objects interfering with these ports will result in reduced engine output, overheating, and electrical component fault/malfunction.
- Operating the equipment in dusty or excessively salty location can result in a clogged radiator or overheating resulting in malfunction/fault or reduced insulation of electrical components. Be sure to thoroughly inspect and perform maintenance if using in such locations.

7. Load Connections

7-1. Load Cable Selection

⚠ CAUTION : PROPERTY DAMAGE

- Cable burnout could occur due to generated heat if the load current exceeds the allowable current of the cable.
- The voltage drop between cables is large if the cable is excessively long or thin, resulting in decreased input voltage to equipment using the generator, thereby causing decreased performance, faulty operation and malfunction.

Select cable for use that has sufficient thickness and an allowable current for use, and distance from the generator to the equipment using the generator.

< Note >

- Select cable with a thickness that ensures that the voltage drop across the cable will be within 5% of the rated voltage.

■ Load Cable Selection Tables

(Ex.) If used voltage is 240 V and voltage drops by 12 V.

Three-phase: Cabtyre cables

(Unit: AWG)

Length Current	100 ft (30 m) or less	200 ft (61 m)	300 ft (91 m)	400 ft (122 m)	500 ft (152 m)	600 ft (183 m)
50 A	10	8	6	4	4	2
100 A	8	4	2	1	1	1/0
150 A	6	2	1	1/0	2/0	3/0
200 A	4	1	1/0	2/0	3/0	4/0
250 A	4	1	2/0	3/0	4/0	—
300 A	2	1/0	3/0	4/0	—	—

(Ex.) If used voltage is 208 V and voltage drops by 10.4 V.

Three-phase: Cabtyre cables

(Unit: AWG)

Length Current	100 ft (30 m) or less	200 ft (61 m)	300 ft (91 m)	400 ft (122 m)	500 ft (152 m)	600 ft (183 m)
50 A	10	6	6	4	2	2
100 A	6	4	2	1	1/0	1/0
150 A	6	2	1	1/0	2/0	3/0
200 A	4	1	1/0	3/0	4/0	4/0
250 A	2	1/0	2/0	4/0	—	—
300 A	2	1/0	3/0	4/0	—	—

(Ex.) If used voltage is 120 V and voltage drops by 6 V.

Single-phase Cabtyre cables

(Unit: AWG)

Length Current	100 ft. (30 m) or less	200 ft. (61 m)	300 ft. (91 m)	400 ft. (122 m)
10 A	14	10	8	8
20 A	10	8	6	4
30 A	8	6	4	2
50 A	6	4	2	1
100 A	4	1	2/0	3/0
150 A	2	2/0	4/0	—
200 A	1	3/0	—	—
250 A	1/0	4/0	—	—
300 A	2/0	—	—	—
350 A	2/0	—	—	—
400 A	3/0	—	—	—
450 A	3/0	—	—	—
500 A	4/0	—	—	—

7-2. Connecting Load Cables

⚠ WARNING : ELECTRIC SHOCK

- Always turn all the breakers OFF, place the starter switch in the STOP position and stop the engine before connecting / disconnecting the load cable to the output terminal or receptacle.
- Close the output terminal cover before operating.
- Do not insert a pin, needle or other metal object into the receptacle.
- Do not touch the generator if the generator or casing becomes wet during operation.

⚠ CAUTION : FIRE

- Do not connect the generator output to indoor wiring.

< Note >

- When connecting a load, check that the generator output setting, output terminal connection position, and load power source are all matching.
- If using the N terminal, be careful that the currents of each phase are uniform.
- If using three-phase output simultaneously with a single-phase three-wire type output, use in a range where the total current does not exceed the rated current.
- If using three-phase output simultaneously with a single-phase three-wire type output, be careful as it is possible for the outputs to mutually affect each other.
- Use proper tools when connecting a load to sufficiently tighten the connection. Failure to sufficiently tightened will result in cable burnout.
- Terminal cover must remain closed during operation or breaker will trip.

(1) Three-Phase Output Terminal

■ For three-phase load:

- Terminal voltage is 208/240/480 V.

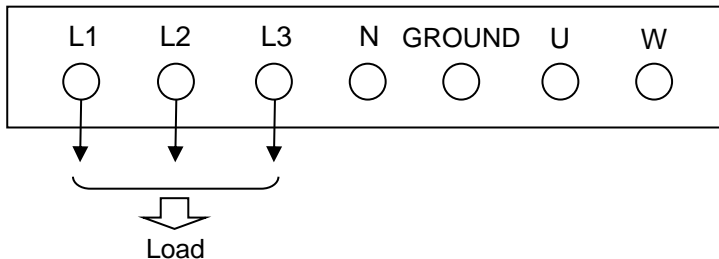

■ For single-phase load:

- Terminal voltage is 120/139/277 V.

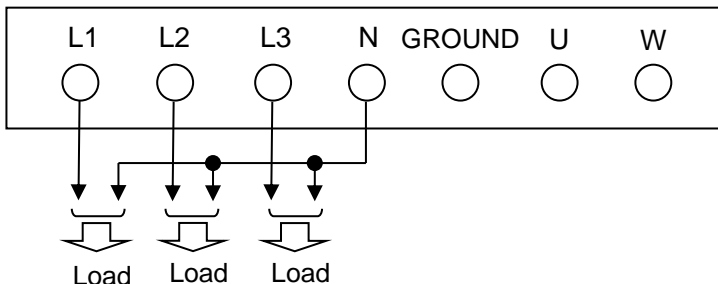

- For single-phase load:
 - Terminal voltage is 208/240/480 V.

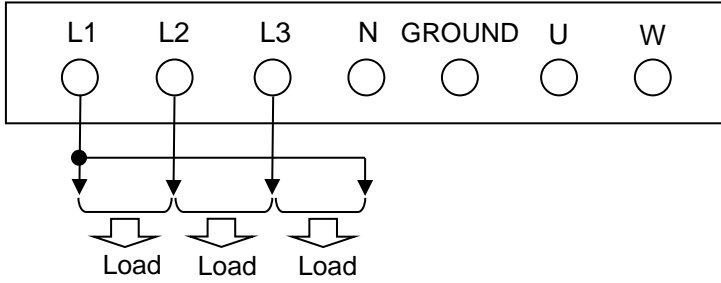

(2) Single-Phase Three-Wire Output Terminal and Receptacle

- For single-phase three-wire type load:
 - U-W terminal voltage is 240 V.
 - U-N terminal voltage is 120 V.
 - W-N terminal voltage is 120 V.

- For single-phase 240 V load:

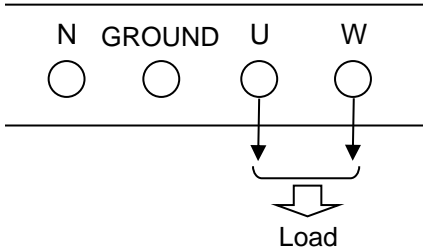

- For single-phase 120 V load:

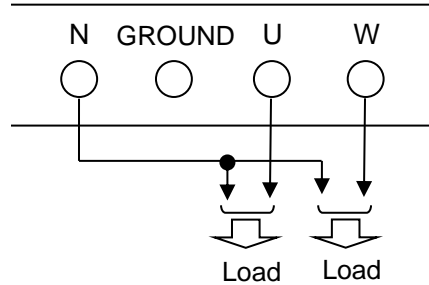

- Single-phase 120V receptacle, single-phase 240/120V receptacle

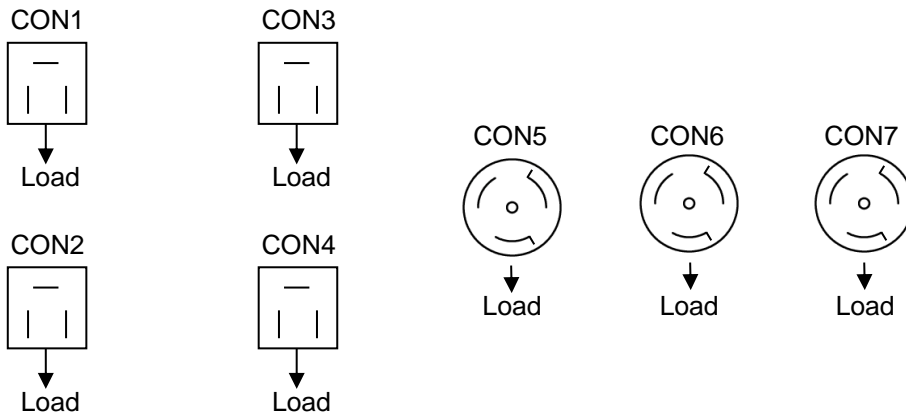

■ Power available for use by each output terminal and receptacle are as show below.

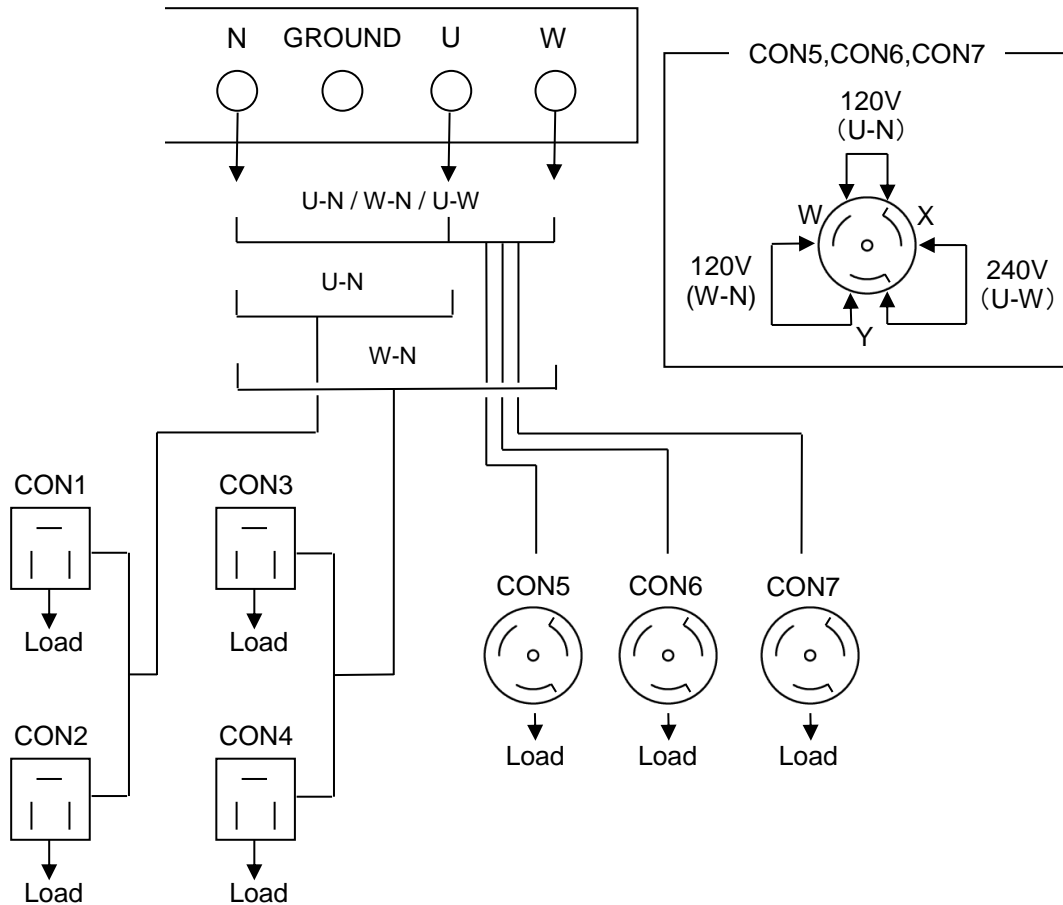

■ Use is possible up to the kVA as shown below.

(Unit: kVA)

1-phase, 3-wire output terminal		1-phase 120 V receptacle				1-phase 240/120 V receptacle			Total
		CON1	CON2	CON3	CON4	CON5	CON6	CON7	
U-W	108/ [54]*	Total 2.4		Total 2.4		12	12	12	108/ [54]*
U-N	54/ [27]*								54/ [27]*
W-N	54/ [27]*								54/ [27]*

* Figures in brackets are used when set to 480 V.

< Note >

- If using a single-phase 120 V (between output terminals U-N and W-N), connect an equivalent load between U-N and W-N.
- If using a single-phase three-wire output terminal simultaneously with a receptacle output, make sure that currents passing through each phase is less than the rated current of this generator.
- If using at the three-phase 480 V setting, the output voltage of the single-phase three-wire type is single-phase 240/120 V, which is the same as the three-phase 208/240 V setting. Accordingly, care must be taken to not draw an excessive load as the available power is only one half.

8. Pre-Operation Inspection

⚠ WARNING : INJURY

- Do not open the check door when the starter switch is in the AUTO or START position. It will cause injury by rotating parts such as cooling fans and fan belt.
- Always turn the starter switch to the STOP position and stop the engine, then close and lock OPERATION PANEL DOOR before checking or maintaining the engine or any equipment.

⚠ CAUTION : BURNS

- Do not touch the engine and surrounding components immediately after stopping the engine as they are still extremely hot.

⚠ CAUTION : FIRE

- Always be sure to wipe up any spilled fuel or oil.

8-1. Checking Engine Oil

To check the engine oil, keep the equipment in leveled position, remove the oil level gauge and wipe so that no oil remains, and then re-insert the dipstick fully. Prior to starting the engine, make sure to fill the engine oil through the oil filler until it reaches the MAX line.

< Note >

- Wait approximately five minutes or more after stopping the engine or adding oil before checking the oil level again.
- An accurate oil level reading cannot be obtained if the generator is not placed in leveled position.
- Do not overfill with oil to avoid engine damage.

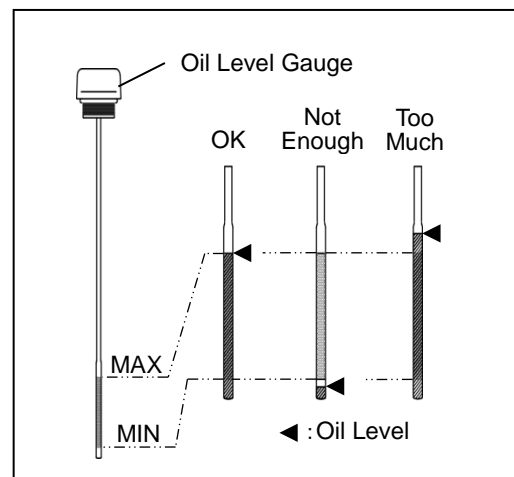
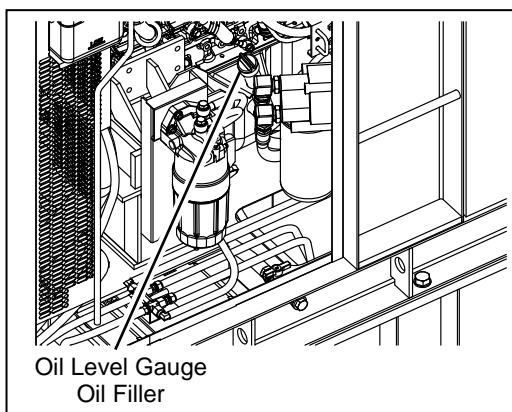

(1) Types of Engine Oil

Use only API service-type CJ-4 class.

(2) Engine Oil Viscosity Grades

Use a diesel engine oil with an appropriate viscosity corresponding to the ambient temperature (refer to the table).

○ Relation of Viscosity/Temperature

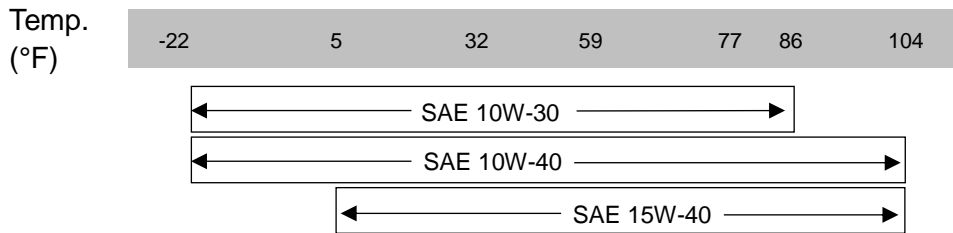

(3) Engine Oil Replacement Amount

Total Lubrication Oil Amount
10.5 gal.

Value in parenthesis is the filter capacity

8-2. Checking Coolant

CAUTION: BURNS



- Do not open the radiator cap immediately after stopping the engine. Do so will result in hot steam gushing out.
- Hot steam gushes out from the coolant sub-tank if the generator overheats. Do not touch the coolant sub-tank.

Check that the sub-tank coolant level is in between FULL and LOW. If the sub-tank coolant is lower than the LOW level, add coolant to the sub-tank and radiator.

(1) Filling the Sub-Tank

- 1 Remove the sub-tank cap.
- 2 Fill the sub-tank with coolant until it reaches the FULL line.
- 3 Re-attach the cap.

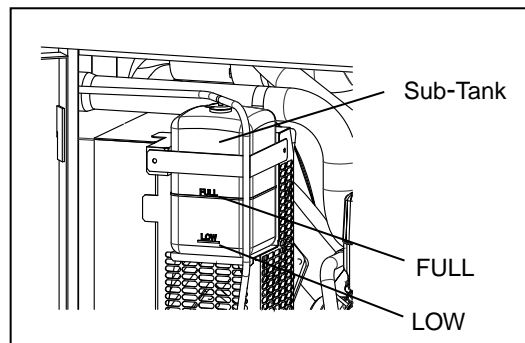

(2) Filling the Radiator

- 1 Remove the radiator plate.
- 2 Remove the radiator cap.
- 3 Fill with coolant through the filler neck until the radiator is full.
- 4 Re-attach and tighten the radiator cap.
- 5 Attach the radiator plate.

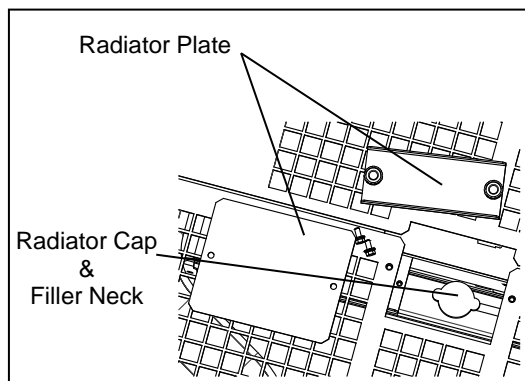

< Note >

- Use GM SPEC 6277M or equivalent.
- Use a 50:50 mix of Long Life Coolant (LLC).
- Always use potable water when mixing the coolant.
- Use LLC with the same mixture ratio in the coolant sub-tank.
- Do not increase the LLC mixture ratio unless necessary. Doing so could result in overheating or another fault/malfunction.
- If adding LLC, be sure to use the same brand/type that is still in the generator.
- Do not mix different brands/types. Doing so could result in a chemical reaction and the creation of toxic substances.

- Change the LLC every 1,000 hours or every year.
- LLC is a toxic substance. Wear rubber gloves and other protective wear when handling.
- If someone mistakenly ingests LLC, induce vomiting immediately and seek medical care.
- If LLC gets on skin or clothing, wash with water immediately.
- LLC is flammable. Store in a location where flame is prohibited and it cannot be accessed by children.
- Engine coolant could leak if the radiator is not completely tightened or there is a gap in the seating face. Always be sure to securely tighten the radiator cap.
- Do not add engine coolant past the FULL level line of the coolant sub-tank.

(3) Coolant Capacity

Total Coolant Capacity
8.7 gal.

Value in parenthesis is the sub-tank capacity.

8-3. Checking the Fan Belt

(1) Fan Belt Tension

Press the middle of the fan belt with a force of approx.98N and check whether the amount of deflection is within the range of standard values.

Standard value [amount of deflection]
0.2 - 0.3 in

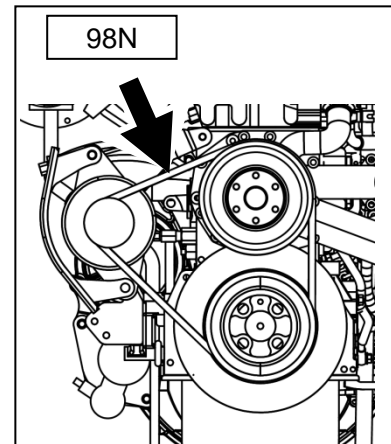

(2) Fan Belt Condition

Check the fan belt for damage and replace if any damage or other fault is found.

(3) Fan Belt Adjustment

- 1 Remove the fan guard.
- 2 Loosen the Lock nut and Mounting Bolt of the alternator.
- 3 Turn the Adjusting bolt until the belt tension falls within the standard value range.
- 4 Securely tighten the Lock nut and Mounting Bolt of the alternator to the specified torque.
- 5 Attach the fan guard.

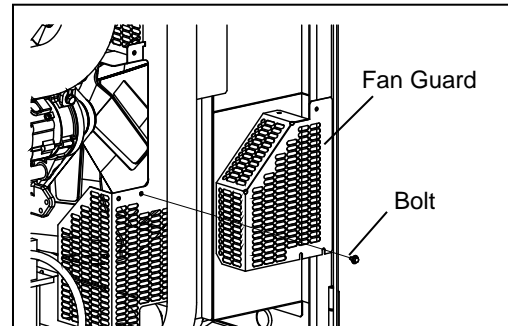

Lock Nut tightening torque
76 N·m
Mounting Bolt tightening torque
127 N·m

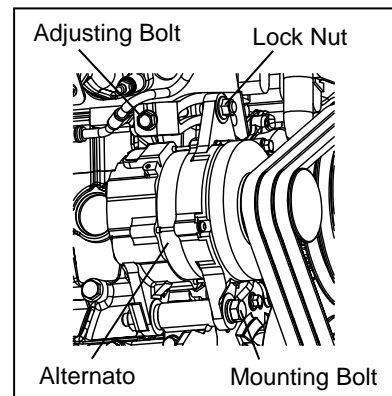

(4) Replacing the Fan Belt

Request the authorized distributor where the generator was purchased to replace the fan belt.

< Note >

- Use of a loose or damaged fan belt could result in overheating or insufficient charging.
- Do not operate the generator if fan guard has been removed.

8-4. Checking the Fuel

⚠ CAUTION : FIRE

- This generator uses diesel fuel. Always be sure to stop the engine and not bring flames close when inspecting fuel or refueling. Wait until the engine has cooled before performing such procedures.
- If fuel spills, always be sure to drain off the spilled fuel. (Refer to section “**10. Inspection/Maintenance (15) Flushing Liquid in Spill Containment**”.)

Check if there is a sufficient amount of fuel and add fuel if insufficient.

The fuel level on the control panel will only display the fuel level for the internal fuel tank.

Be sure to close the cap tightly after refueling

< Note >

- Use Diesel fuel, ASTM D975 No.2-D, S15. Engine is designed to operate on Ultra Low Sulfur Diesel Fuel only. Use of any other fuel may result in engine no longer operating in compliance with emissions requirements.
- The fuel supply pump, injectors and other parts of the fuel system and engine can be damaged if any fuel or fuel additives are used other than those specifically recommended by the engine manufacturer.
- Carefully add fuel until the tank is full.
- Always be sure to wipe up any spilled fuel.

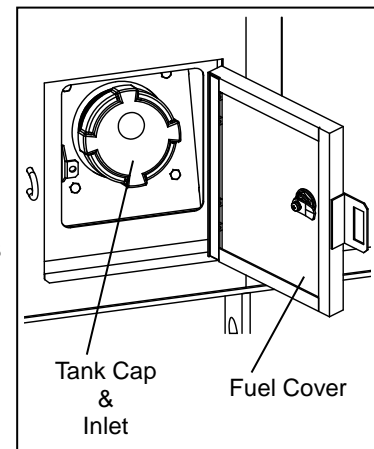

8-5. Checking the DEF (Diesel Exhaust Fluid)

⚠ CAUTION : FIRE

- Do not put anything other than DEF (gasoline, diesel fuel, etc.) in the DEF tank. Also, do not put DEF diluted with water or other liquids.

Check if there is a sufficient amount of DEF and add DEF if insufficient.

< Note >

- Use DEF that is compliant with the ISO (International Organization for Standardization) 22241 standard defined for AUS 32, or the API (American Petroleum Institute) standards.
- Adding liquids, etc., other than DEF may result in a malfunction of the SCR system.
- Do not fill with DEF past the FULL position of the DEF tank.
- Put DEF in the main tank and sub tank respectively. The tank is connected at the bottom, but if it is replenished from one side, it takes time until the level gauge is displayed correctly.
- The level gauge, mounted in front of the DEF tank, is intended to prevent oversupply and overflow of DEF, not to measure the remaining amount of DEF. Check the remaining amount of DEF on the DEF LEVEL of SCR SYSTEM MONITOR, not using the level gauge.
- To add DEF, set the starter switch to the “STOP” position and stop the engine.

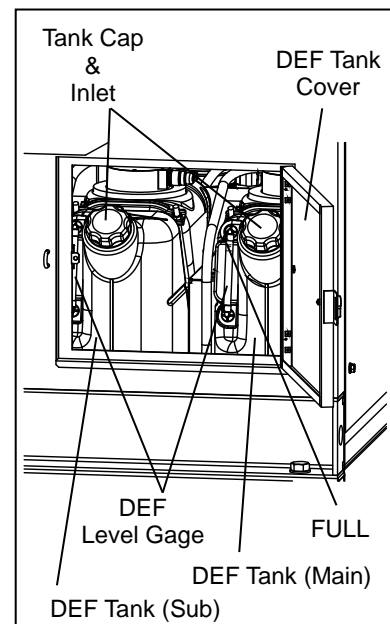

- Always be sure to wipe up any spilled DEF.
- DEF is a clear, colorless, and harmless aqueous solution. It is normal for DEF to emit an odor in some circumstances.
- DEF may cause inflammation in rare circumstances depending on its constitution. In such cases, take the following actions.
 - In the case of contact with skin, wash off with water. Failure to do so may result in irritation for those with sensitive skin.
 - In the case of accidental ingestion, drink one or two glasses of water or milk and consult your physician immediately.
 - In the case of contact with eyes, immediately wash out with large amounts of water for at least 15 minutes and consult your physician.

8-6. Checking the Spill Containment



- If fuel or oil is leaking, repair the leaking location before operating.

Open the check door and check the inside of the spill containment. Flush out any accumulated liquid. Refer to section “10. **Inspection/Maintenance (15 Flushing Liquid in Spill Containment)**” for flushing procedures.

< Note >

- The types of liquids that can accumulate in the spill containment include oil, fuel, coolant, battery fluid and DEF such that it is not possible to distinguish between rain water and other liquids. Dispose of flushed liquids according to the related laws and regulations.

8-7. Checking for Fuel, Oil and Coolant Leak



- If fuel or oil is leaking, repair the leaking location before operating.

Open the check door and check for fuel, oil and coolant leakage from fuel piping connections and similar locations.

8-8. Checking the Battery

California Proposition 65



Batteries, battery posts, terminals and related accessories contain lead and lead compounds, and other chemicals known to the State of California to cause cancer and birth defects or other reproductive harm. WASH HANDS AFTER HANDLING.



- Wear rubber gloves and other protective wear to protect eyes, skin and clothing from the battery fluid which contains diluted sulfuric acid. If the battery fluid contacts eyes or skin, wash out immediately with a large amount of water. Be sure to receive medical treatment, especially if the fluid contacts the eyes.



- Never use or recharge the battery if the fluid level is below the minimum level.
- Do not create sparks or bring flame near the battery as it generates flammable gas.

- 1 Check the fluid level, and add distilled water until it reaches the upper level when the fluid level is near the lower level.
- 2 Check the terminals for looseness and tighten properly.

< Note >

- It is necessary to recharge the battery when the specific gravity of the battery fluid is 1.23 or less. Request the authorized distributor where the generator was purchased to recharge the battery.

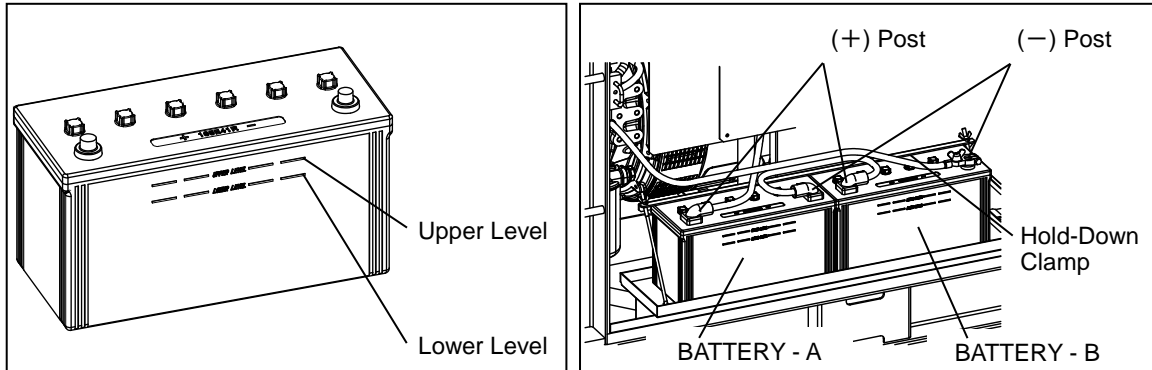

■ Replacing the Battery

< Note >

- Two batteries are connected in series order. Whenever you replace battery or disconnect cables, always proceed with the following steps, otherwise battery may short-circuit.

(1) BATTERY - A

- 1 Remove the clamp and cable from negative (-) post from the battery on the right side. (Always be sure to remove the negative (-) side first.)
 - 2 Remove the clamp and cable from positive (+) post from the battery on the right side.
 - 3 Remove the clamp and cable from negative (-) post from the battery on the left side. (Always be sure to remove the negative (-) side first.)
 - 4 Remove the hold-down clamp from the battery on the left side.
 - 5 Remove the clamp and cable from positive (+) post from the battery on the left side.
 - 6 Remove the left side battery from the seat.
- * Install the battery by performing the above procedures in the reverse order. (First connect the positive (+) cable of the replaced battery.)

(1) BATTERY - B

- 1 Remove the clamp and cable from negative (-) post from the battery on the right side. (Always be sure to remove the negative (-) side first.)
 - 2 Remove the hold-down clamp from the battery on the right side.
 - 3 Remove the clamp and cable from positive (+) post from the battery on the right side.
 - 4 Remove the right side battery from the seat.
- * Install the battery by performing the above procedures in the reverse order. (First connect the positive (+) cable of the replaced battery.)

< Note >

- Make sure that the removed cable does not come in contact with the battery post.
- Do not disconnect the battery cable immediately after the engine stop. The SCR continues to operate for approximately 3 minutes even after the starter switch is set to the "OFF" position. Wait for at least 3 minutes before disconnecting the battery cables.

9. Operating Procedures

9-1. Initial Startup/Pre-Check

WARNING : EXHAUST GAS POISONING

- Do not operate the generator in poorly ventilated areas such as indoors or tunnels, as the exhaust gas of the engine contains substances that are harmful to human health.
- Do not direct exhaust fumes at bystanders or buildings.

WARNING : INJURY

- Always be sure to check that the breakers on load side and switches for any equipment using the generator are at OFF before turning the breaker to ON. Also be sure to advise personnel on the load side that power will be turned on before operating the breaker.
- Close all doors and lock them during operation.

CAUTION : FIRE

- Do not carry flammable items (such as fuel, gas and paint) or items that are highly combustible near the generator as the muffler, exhaust gas and other parts become extremely hot.
- Position this generator 3 ft. (1 m) or more from walls or other hindrances, and on a level surface.

CAUTION : INJURY

- Do not operate the generator if it has been modified or any parts have been removed.
- Position the generator on a level stable surface so that it cannot slide or move in any manner.
- Before starting operation, always be sure to turn off all switches of equipment being used and all breakers to OFF.

< Note >

- Check that the surrounding area is safe before starting the engine.
- When there are multiple workers who are working together, they must mutually signal each other before starting the engine.
- Do not use in an area with high temperature or humidity, or an area with a large amount of dust.
- Do not open any doors during operation. Operating with door open can negatively affect cooling effect, resulting in an equipment malfunction.
- Use ear protection if the level of noise is high. Failure to do so could result in hearing damage.
- Please be careful about a strong wind and the opening and shutting of the door. If a door is opened suddenly and is closed, and a finger might be sandwiched.

(1) Manual Start

- 1 Turn off the three-phase and single-phase breakers on the operation panel of this machine.
- 2 Turn the Throttle switch to IDLING.
- 3 Set the ACCESSORY switch to OFF, and use the safety cap to cover it.
- 4 Set the STARTER SWITCH selector to START position.

< Note >

- The warm-up process starts automatically.
 - Please keep in mind that the muffler may emit some smoke when engine is started.
 - Never turn accessory switch ON during operation. The engine keeps running while accessory Switch is ON.
- 5 Let engine idles for approximately for five minutes.
 - 6 Turn the Throttle switch to RUN position.
 - 7 Adjust the voltage regulator dial to the specified voltage.
 - 8 Turn the breakers to ON to start AC power delivery.

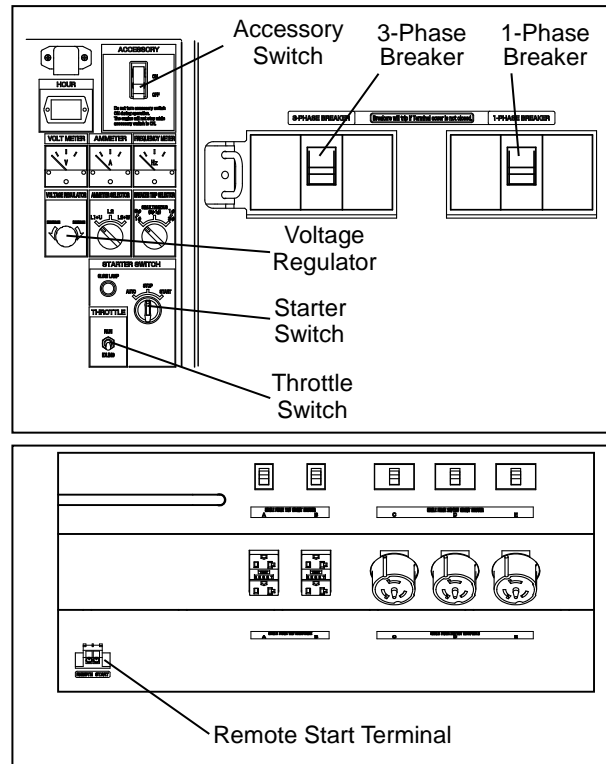

(2) Auto Start

- 1 Use the VOLTAGE REGULATOR dial to adjust the voltage to the specified value.
- 2 Turn on the three-phase and single-phase breakers on the operation panel of this machine.
- 3 Set the ACCESSORY switch to OFF position, and use the safety cap to cover it.
- 4 Set the STARTER SWITCH selector to AUTO position.
- 5 The engine starts when the "REMOTE START" terminal closes.

< Note >

- The engine is running at 1800rpm with 60Hz regardless of throttle switch position if you leave starter switch in AUTO position.
- Please keep in mind that the muffler may emit some smoke when engine is started.
- Never turn accessory switch ON during operation. The engine keeps running while accessory Switch is ON.

9-2. 208/240/480V Switching Selection

WARNING : ELECTRIC SHOCK

- If performing any electric voltage switching, turn all breakers to OFF and stop operation.
- Lock the generator using a padlock so that no one except for designated operators can operate switches.

CAUTION : PROPERTY DAMAGE

- Check that the voltages of the generator output setting, output terminal connection and load power source are consistent.

- 1 Turn the three-phase and single-phase breakers on the operation panel to OFF and stop operation.
- 2 Turn the lever of the voltage selector switch to the desired output setting.
- 3 Three-phase 208/240/480 V power is output to the three-phase output terminal. Refer to section “7-2. Connecting Load Cables”.
- 4 Start the engine and turn the three-phase breaker to ON to transmit power to the three-phase output terminal.

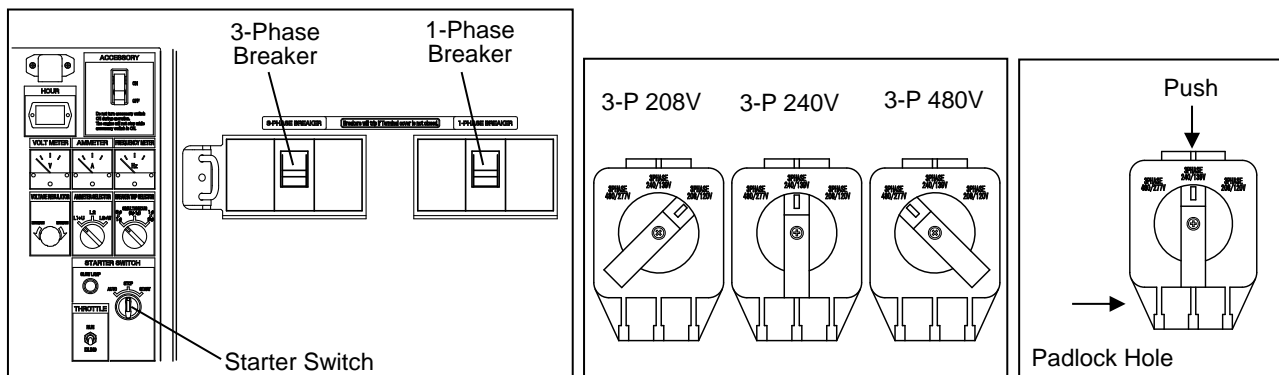

< Note >

- If using at the three-phase 480 V setting, the output voltage of the single-phase three-wire type is single-phase 240/120 V, which is the same as the three-phase 208/240 V setting. Accordingly, care must be taken to not draw an excessive load as the available power is only one half.

9-3. Procedures during Operation

(1) Checks after Startup

- Make sure that all meters and indicators are in normal status.
(Refer to section “5. Equipment”.)
- Check that there is no abnormal vibration or noise.
- Check that the exhaust gas color is normal. When operation is normal, the exhaust gas should be colorless or slightly bluish.

< Note >

- If abnormal, stop using this generator and request authorized distributor where the generator was purchased to repair the generator.

(2) Adjustment during Operation

During load operation, check the voltmeter and finely adjust voltage using the voltage regulator dial.

- Bleeding air from the fuel system when the engine stops due to running out of fuel.

- 1 Add fuel to the generator.
- 2 Set the ACCESSORY switch ON, activate the electromagnetic pump. Please do not start the engine.
- 3 Loosen the air bleeder plug of the fuel filter sufficiently, and operate the priming pump until the fuel comes out.
- 4 Tighten the air bleeder plug and operate the priming pump 10 times or more until the fuel filter is filled with fuel.
- 5 Wait for approximately 1 minute, and loosen the air bleeder plug to remove the air from the fuel filter.
- 6 Repeat Steps 3 through 5 at least 3 times until air does not come out from the air bleeder plug.
- 7 Securely tighten the air bleeder plug, and wipe off the fuel spread around.
- 8 Set the ACCESSORY switch to OFF, and use the safety cap to cover it.
- 9 Start the engine. If the engine does not start at this time, repeat the procedure from Step 4.

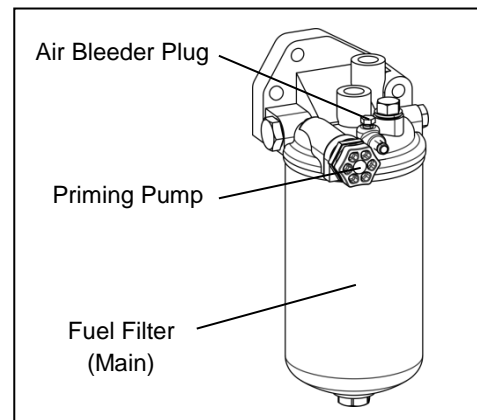

Air bleeder plug tightening torque

7.9 – 11.7 N·m

< Note >

- Turn the throttle switch to IDLING, start the engine and check that the air is completely bled from the system. If air bleeding is not complete, engine rotation will not be stable. In that case, repeat the air bleeding operation.
- Be careful not to over-tighten the air bleeder plug.
- Always be sure to wipe up any spilled fuel.

9-4. Stopping Operation



CAUTION : BURNS

- Do not touch the engine and surrounding components immediately after stopping the engine as they are still extremely hot.

(1) Manual Start

- 1 Turn the switches and breakers on the load side to OFF.
- 2 Turn the three-phase and single-phase breakers on the operation panel to OFF.
- 3 Confirm that the "ACCESSORY" switch is set to OFF.
- 4 Turn the Throttle switch to IDLING.
- 5 The engine cools down for approximately three minutes.
- 6 Turn the starter switch to STOP.

< Note >

- Never turn accessory switch ON during operation. The engine keeps running while accessory switch is ON.
- Set the STARTER SWITCH selector to STOP position if the generator will not be used for a prolonged period. If you leave the selector in the AUTO or START position, the standby current may drain the battery.

(2) Auto Start

- 1 The engine stops when the REMOTE START terminal opens.
- 2 Set the STARTER SWITCH selector to STOP.

< Note >

- Never turn accessory switch ON during operation. The engine keeps running while accessory switch is ON.
- Set the STARTER SWITCH selector to STOP position if the generator may not be used for a prolonged period. If you leave the selector in the "AUTO" or START position, the standby current may drain the battery.

9-5. Protective Functions



WARNING : INJURY



- Do not open the check door when the starter switch is in the AUTO or START position. It will cause injury by rotating parts such as cooling fans and fan belt.
- Always turn the starter switch to the STOP position and stop the engine, then close and lock OPERATION PANEL DOOR before checking or maintaining the engine or any equipment.



CAUTION : BURNS



- Do not touch the engine and surrounding components immediately after stopping the engine as they are still extremely hot.
- Hot steam gushes out from the coolant sub-tank if the generator overheats. Do not touch the coolant sub-tank.

This generator is equipped with functions to automatically stop operation when there is a fault/malfunction during operation, and one to warn the operator of the fault location by use of indicator lamps. Check the fault location when the engine is automatically stopped or an indicator lamp illuminates to stop the engine.

Protection Feature List

No.	Abnormality	Action	Breaker Trip	Engine Automatic Shutdown	Warning Lamp Flash	Cause
1	Engine Monitor Lamp	High Water Temperature	–	○	○	Activates due to high water temperature in the engine Default : 212°F (100°C)
2		Low Oil Pressure	–	○	○	Activate due to low oil pressure in the engine Default 7 psi (0.48 x 100 kPa)
3		Insufficient Battery Charge	–	–	○	Activates in battery charge Impossible
4		Engine Overspeed	–	○	○	Engine speed is too fast (2070 rpm or more)
5		Air Filter Clogging Up	–	–	○	The element is clogged making it necessary to clean or replace the element.
6		Spill Containment Fluid Level Check	–	–	○	Spill containment accumulated fluid has exceeded the specified level making it necessary to flush the fluid.
7		Spill Containment Fluid Overflow	–	○	○	Spill containment accumulated fluid has exceeded the specified level making it near the fill.
8		Engine Malfunction	–	(○)	○	Some other engine fault occurs during operation
9	SCR System Monitor Lamp	DEF Empty	–	○	○	DEF remaining amount 0%
		SCR system error and DEF quality abnormality	–	○	○	An abnormality occurs in the SCR system during operation If anything other than DEF is added or the DEF is diluted with water or other liquids
10	Overload		○	–	–	Activates in overload

* ○ indicates the automatic activation.

9-6. Connecting with External Fuel Tank

CAUTION : FIRE

- Always make sure that the engine is stopped when working on piping.
- Always be sure to wipe up any spilled fuel.
- After working on the piping, check that there is no fuel leakage.

■ Capacity of the external tank should be less than 400 gal (1515 liters).

When refueling the external fuel tank, supply DEF to the internal DEF tank.

1 Turn the 3way fuel valve lever to the “B” side.
(Position for using the internal tank.)

2 Remove the plugs(R1/2”) from both the external fuel inlet and the external fuel return.

3 Connect the hoses from an external fuel tank, as shown below.

4 Turn the 3way fuel valve lever to the “A” side.
(Position for using the external tank.)

5 Bleed air from the external tank connecting hose. Fuel can be supplied from the external tank after completing the above procedures.

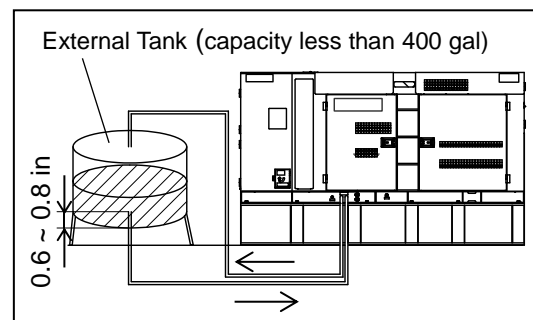
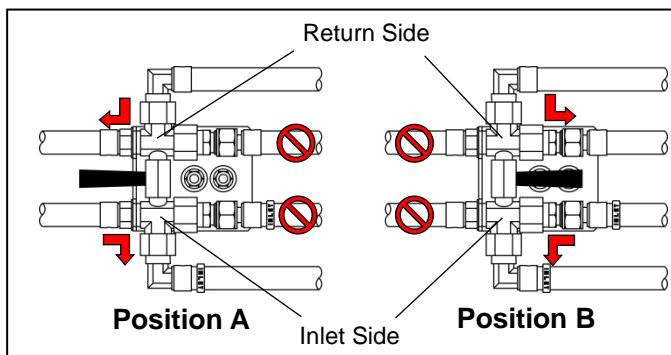
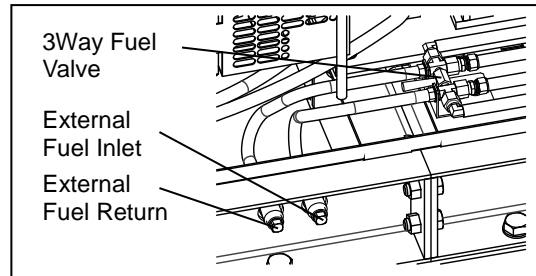

< Note >

- If using a hose for the piping, use oil-resistant hose with an internal diameter of 0.31 to 0.35 in (8 to 9 mm).
- Set the fuel level of the external fuel tank from 0 to 10 ft. (3 m) from the underside of this generator. The fuel level of the external fuel tank being lower than this generator will result in poor engine operation or stoppage.
- Turn the 3way fuel valve lever to the “B” side in order to prevent fuel from flowing out from the external tank fuel inlet/return.
- Turn the lever completely as far as possible. If the lever is not completely pressed to either side, it might not be possible to supply fuel causing the engine to stop.
- Set the supply side so that it is 0.6 to 0.8 in. (15 to 20 mm) above the underside of the tank in order to prevent foreign material or water from being suctioned from inside the external fuel tank.
- Set the external fuel tank return side at the same height as the supply side in order to prevent poor engine operation due to air mixed in with the fuel.
- Refer to section “9-3 Procedures during Operation” for air bleeding.
- Some air may remain in hoses or pipes immediately after connecting the external fuel tank resulting in unstable engine speed and engine stoppage.
- Do not leave the generator unattended for unmanned operation until you have confirmed that the engine speed is stable.

10. Inspection/Maintenance

California Proposition 65

WARNING

Batteries, battery posts, terminals and related accessories contain lead and lead compounds, and other chemicals known to the State of California to cause cancer and birth defects or other reproductive harm. WASH HANDS AFTER HANDLING.

WARNING : ELECTRIC SHOCK / INJURY

- Do not touch output terminals or internal electric parts while the generator is operating.
- Do not open the check door when the starter switch is in the AUTO or START position. It will cause injury by rotating parts such as cooling fans and fan belt.
- Always turn the starter switch to the STOP position and stop the engine, then close and lock OPERATION PANEL DOOR before checking or maintaining the engine or any equipment.
- Use the lifting hook to lift the machines, and do not lift up by using other parts. Use of such could result in the generator falling.
- No persons should be under a suspended generator at all time.

CAUTION : FIRE

- Always be sure to wipe up any spilled fuel or oil.

CAUTION : BURNS

- Do not touch the engine and surrounding components immediately after stopping the engine as they are still extremely hot.
- Do not open the radiator cap immediately after stopping the engine. Do so will result in steam gushing out.
- Hot steam gushes out from the coolant sub-tank if the generator overheats. Do not touch the coolant sub-tank.
- Do not touch the SCR system and surrounding components immediately after stopping the engine as they are still extremely hot.

CAUTION : INJURY

- Personnel performing suspension work must wear protective gear such as helmets, safety shoes and gloves.
- Always be sure to use lifting hooks when suspending the generator, and raise it slowly at a completely vertical angle.

Perform periodic inspection and maintenance according to the following table in order to constantly maintain this generator in good working condition. Use the hour meter as a reference for the operating time.

< Note >

- All procedures except for pre-operation inspection should be performed by specialized technicians.
- Request authorized distributor where the generator was purchased to perform the procedures in the table with a “●”.
- Always be sure to use genuine parts or those indicated specifically for replacement parts.
- Use a container to catch fluid bled from this generator that is large enough to prevent the fluid from spilling on the ground. Dispose of oil, fuel, coolant (LLC), filter, battery, DEF and other hazardous materials according to laws and regulations concerning industrial waste. Contact authorized distributor where the generator was purchased if you have any inquiries regarding proper disposal.
- When check doors are open during maintenance, take measures so that unrelated personnel cannot accidentally come close to the generator. Close all doors and covers if you are going to be away from this generator.
- Please be careful about a strong wind and the opening and shutting of the door at the sloping place enough. When door is opened or closed suddenly, a finger might be sandwiched.

	Description	Daily	Every 250 hrs	Every 500 hrs	Every 750 hrs	Every 1000 hrs	Every 2000 hrs	Every 4500 hrs	Remarks
Engine	Each parts (Clean/Tightening)	○							
	Exhaust color (Check)	○							
	Engine oil (Check/Add)	○							
	Engine oil (Replace)			○					
	Oil filter (Replace)			○					
	PCV filter (Replace)			○					
	Coolant (Check/Add)	○							
	Coolant Replace / bleeding EGR					○ Every 1 years			
	Fuel filter (Check/Drain excess Water and sediments)	○							
	Fuel filter (Replace)			○					
	Fuel tank (Drain water/Clean)		○ (Drain)		● (Clean)				
	Electromagnetic pump filter (Clean/Replace)			○					
	Air cleaner element (Clean/Replace)		○ (Clean)	○ (Replace)					
	Battery fluid level (Check/Add)	○							
	Battery gravity (Check)	○							
	Check for leaks (Fuel/Oil/Coolant)	○							
	Fan belt tension (Check)	○							
Fan belt (Replace)			●						
Intercooler (Drain)			○						

	Description	Daily	Every 250 hrs	Every 500 hrs	Every 750 hrs	Every 1000 hrs	Every 2000 hrs	Every 4500 hrs	Remarks
Engine	Fuel/Coolant/Oil Hoses and Anti-Vibration Rubber (Replace)								● Every 2 years
	Air Hose(Engine/ Intercooler/Air Creaner) SCR system LLC hose								● Every 2 years
	Radiator and Intercooler (Clean)			●					
	Valve clearance (Check/Adjust)					●			
	Supply pump filter (Check/Clean)			●					
	Fuel injector (Check)							●	
	Elimination of carbon in the exhaust pipe line and muffler		○						
	DEF leakage	○							
	DEF filter replacement (SCR system: in the Supply module)							○	
	SCR system inspection							●	
	Dosing module inspection (SCR system)							●	
Generator	Indicators, Gauges Alarms (Check)	○							
	Insulation test		●						
Others	Spill containment fluid (Check/Drain)	○							
	Spill containment (Check/Clean)	○		● (Clean)					
	Cleaning the Rear Cover			○ (Check/Clean)					

(1) Engine Oil Replacement

Replace	Every 500 hours
---------	-----------------

- 1 Set a container to catch spilled engine oil.
- 2 Remove the oil filler cap.
- 3 After removing the oil drain plug and o-ring, open the oil drain valve and drain the engine oil.
- 4 After the oil has been drained, close the oil drain valve and reinsert the oil drain plug with o-ring.
- 5 Add oil through the oil filler until it is at the maximum level while checking the oil level using the oil level gauge.
- 6 Attach the oil filler cap.

< Note >

- Refer to section “8-1. Checking Engine Oil” for engine oil replacement amounts and types.
- After reinserting the oil drain plug and shortly after starting the engine, be sure to always check that there is no oil leakage.
- Always be sure to wipe up any spilled engine oil.

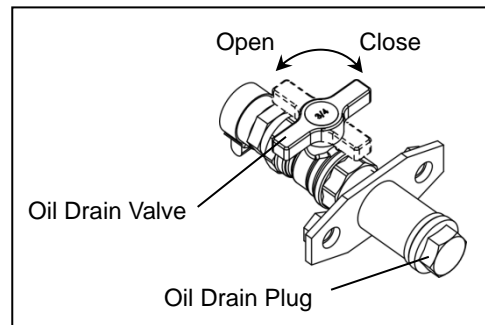
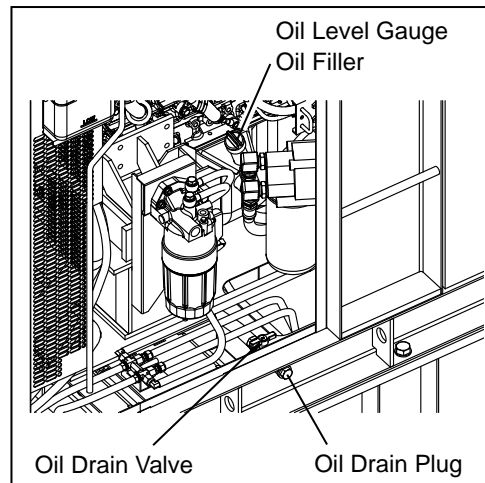

(2) Replacing the Oil Filter

Replace	Every 500 hours
---------	-----------------

- 1 Drain the engine oil.
(Refer to section “(1) Engine Oil Replacement”.)
- 2 Remove the oil filter using a filter wrench.
- 3 Spread a thin layer of oil on a new oil filter gasket.
- 4 Thread the oil filter by hand (do not use a filter wrench), and it in until the gasket contacts the seal surface, and then tighten it with one turn using filter wrench.
- 5 Add engine oil to the generator.
- 6 Shortly after starting the engine, always be sure to check that there is no oil leaking from the seal surface.

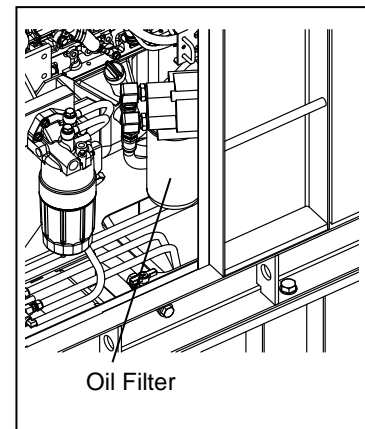

< Note >

- Request the authorized distributor where the generator was purchased to perform this procedure if you do not have a filter wrench.
- Oil filter part no.: 8983758600 (Isuzu part no.)
- Always be sure to wipe up any spilled engine oil.

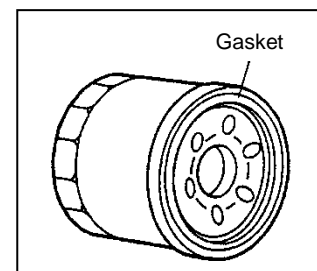

(3) Replacing the PCV (Oil Separator) Filter

Replace	Every 500 hours
---------	-----------------

- 1 Remove the PCV filter bands and PCV filter cover.
- 2 Wipe clean around the PCV filter cap taking care so that no foreign particles entry.
- 3 Remove the PCV filter cap.
- 4 Remove the PCV filter element.
- 5 Install the new PCV filter element.
- 6 Install the PCV filter cap.
- 7 Install the PCV filter cover and bands.

< Note >

- PCV filter part no.: 8980305320 (Isuzu part no.)

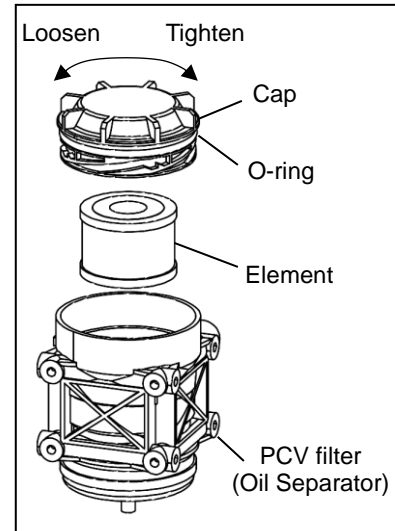
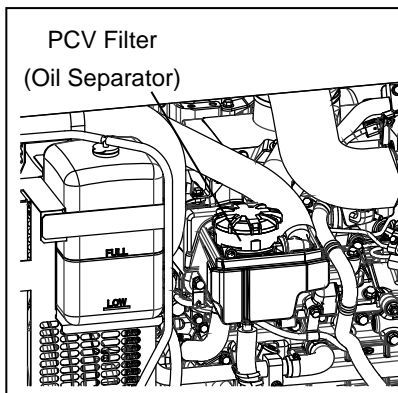
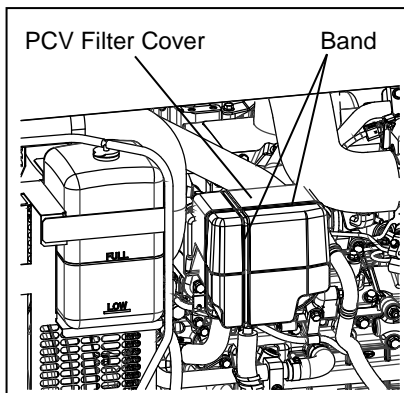

(4) Air Filter Element Cleaning/Replacement

Clean (Outer element)	Every 250 hours
Replace (Inner / Outer element)	Every 500 hours

- 1 Remove the air cleaner clips and cleaner cap.
- 2 Remove the outer element.
- 3 Clean or replace the outer element. Replace by performing the above procedures in reverse order.

< Note >

- Inner air element must not be reused even if it is cleaned.
- Replace the inner element when replacing the outer element.
- Always be sure to turn the cleaner cap in the direction indicated by the arrow.
- Replace the elements earlier if using in an excessively dusty location.
- Do not add oil as this generator uses a dry element.
- Clear foreign material by pinching the vacuator valve once a week in normal operating conditions or daily if operating in a location that is excessively dirty or dusty. Wipe away any dirt or moisture that has adhered to the parts.
- Never touch the elements for any reason except cleaning.

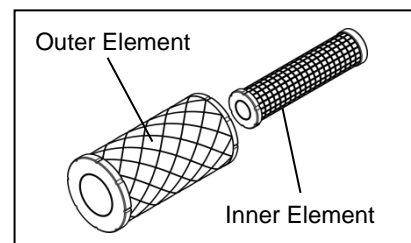
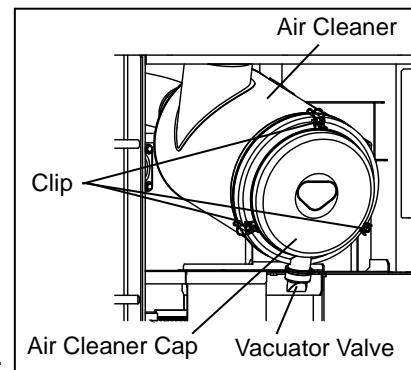

- The mass air flow (MAF) sensor is installed to the air cleaner inlet duct. Refrain from using commercially available cleaning agent to remove dust clinging to the sensor; otherwise the engine output will be reduced.
- Outer Element part no.: P812363 (Isuzu part no.)
- Inner Element part no. : P838813 (Isuzu part no.)
- **Cleaning the air filter element (outer element)**
 If dry dust is adhering : Blow compressed air from inside the element.
 If carbon or oil is adhering : Replace with new parts.

(5) Draining Water from the Fuel Filter (Pre Filter)

Check/Drain	Daily
-------------	-------

Drain water when the float (red) inside the cup floats to the water draining position (bottom of the element).

- 1 Place a container under Fuel Filter to catch spilled water and fuel.
- 2 Loosen the air bleeder plug of the fuel filter sufficiently.
- 3 Loosen the drain plug on the bottom to drain the water.
- 4 When water draining is completed, tighten the drain plug on the bottom.
- 5 Tighten the air-bleeding plug.

Drain plug tightening torque
2 - 3 N·m

Air bleeder plug tightening torque
7.9 - 11.7 N·m

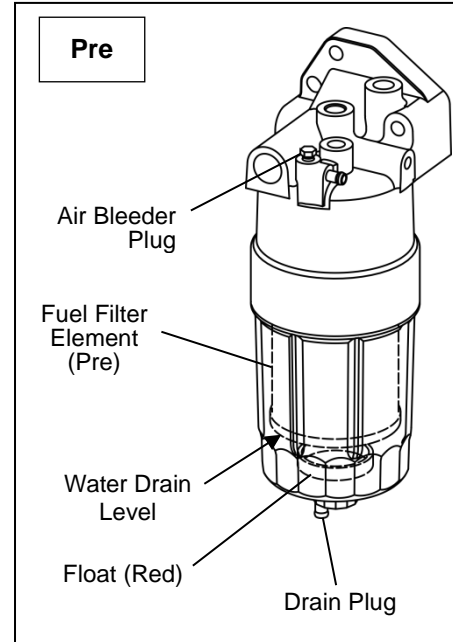

< Note >

- After drainage, start the engine and check that there is no fuel leakage.
- When the water is accumulate in the cup, drain water from the fuel tank.
- Be careful not to over-tighten the drain plug and air bleeder plug.
- Always be sure to wipe up any spilled fuel.

(6) Main Fuel Filter Replacement

Replace	Every 500 hours
---------	-----------------

- 1 Place a container under Fuel Filter to catch fuel spilling out of the filter.
- 2 Remove the filter element (main) using the wrench.
- 3 Before installing the Element, lightly apply engine oil to the Element gasket.
- 4 Screw the new filter into place and tighten it by hand until the gasket contacts the seat. Then, give it additional 2/3 turn or a specified fastening torque to seat the filter.

Fuel Filter Element (Main) tightening torque
25 N·m

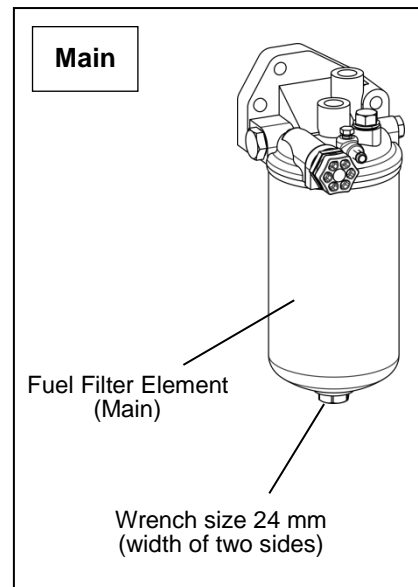

< Note >

- When attaching the Element, check that there is no foreign material adhering to the gasket.
- Be careful not to over-tighten the air bleeder plug.
- After attaching, be sure to always start the engine and check that there is no fuel leakage.
- Always be sure to wipe up any spilled fuel.
- Main filter element part no.: 8983129180 (Isuzu part no.)
- After replacing the filter, always air out the fuel system.
(Refer to section “9-3. Procedures during Operation”.)

(7) Pre Fuel Filter Replacement

Replace	Every 500 hours
---------	-----------------

- 1 Place a container under Fuel Filter to catch fuel spilling out of the filter.
- 2 Loosen the air bleeder plug of the fuel filter sufficiently.
- 3 Loosen the drain plug on the bottom to drain the fuel.
- 4 Remove the outer case of the filter using the specified filter wrench.
- 5 Remove the fuel filter element.
- 6 Install a new fuel filter element.
- 7 Replace the O-ring of the outer case.
- 8 Apply fuel to the each O-ring thinly.
- 9 Screw the outer case into the filter by hand until O-ring contacts to the sealed surface. Fully screw the filter by special filter wrench.
- 10 Tighten the drain plug on the bottom and the air-bleeding plug.

Drain plug tightening torque
2 - 3 N·m

Air bleeding plug tightening torque
7.9 - 11.7 N·m

Outer case tightening torque
28 - 32 N·m

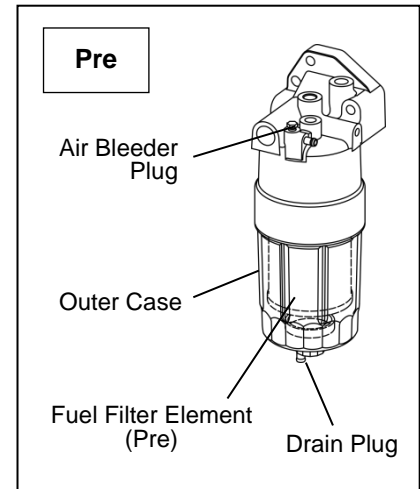

< Note >

- When attaching the cup, check that there is no foreign material adhering to the O-ring.
- Be careful not to over-tighten the drain plug and air bleeder plug.
- After attaching, be sure to always start the engine and check that there is no fuel leakage.
- Always be sure to wipe up any spilled fuel.
- If water is accumulate in the cup, draining water from the fuel tank and the water separator.
- Pre filter element (Including O-ring) part no.: 8980742881 (Isuzu part no.)
- After replacing the filter, always air out the fuel system.
(Refer to section “9-3. Procedures during Operation”.)

(8) Electromagnetic Fuel Pump Filter Cleaning/Replacement

Clean/Replace	Every 500 hours
---------------	-----------------

- 1 Place a container under Fuel Pump to catch spilled fuel.
- 2 Turn the cover, located at the bottom of pump, counter-clockwise and remove cover.
- 3 Remove the filter and gasket.
- 4 Clean the filter with the compressed air and rinse it in the fuel before installing the filter and gasket.
- 5 Reinstall in the reverse order.

< Note >

- After attaching, be sure to always start the engine and check that there is no fuel leakage.
- Always be sure to wipe up any spilled fuel.
- After replacing the filter, always air out the fuel system. (Refer to section “9-3. Procedures during Operation”.)
- When a damage is found on the filter and gasket, replace with new parts.
- Filter kit (Without Gasket) part no. : 8980714010 (Isuzu part no.)
- Gasket kit (Without Filter) part no. : 8980714040 (Isuzu part no.)
- Repair kit (Including Gasket/Filter kit) part no. : 8981731650 (Isuzu part no.)

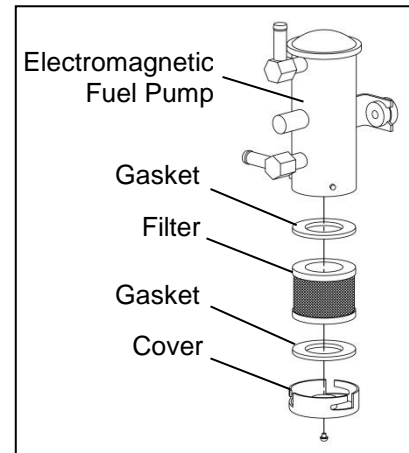

(9) Engine Supply Pump Strainer Cleaning/Replacement

Clean/Replace	Every 500 hours
---------------	-----------------

- 1 Place a container under Supply Pump to catch spilled fuel.
- 2 Remove the joint bolt.
- 3 Clean the strainer with the compressed air and rinse it in the fuel oil and reinstall in the reverse order.

< Note >

- After attaching, be sure to always start the engine and check that there is no fuel leakage.
- Always be sure to wipe up any spilled fuel.
- After cleaning or replacing the strainer, always air out the fuel system. (Refer to section “9-3. Procedures during Operation”.)
- When a phenomenon such as output decrease and engine stop appears, and this phenomenon is not resolved after replacing the fuel filter element, replace the supply pump strainer (together with the joint bolt).
- The supply pump strainer is assembled into the joint bolt located at the inlet side of the supply pump. This joint bolt is a component which cannot be disassembled, so do not pull out the strainer inside.
- Engine Supply Pump Joint Bolt (Including Strainer) part no. : 8980749550 (Isuzu part no.)

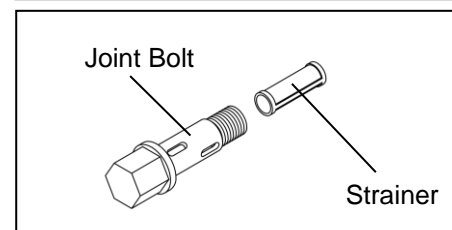
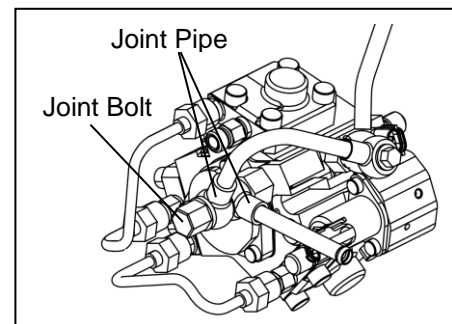
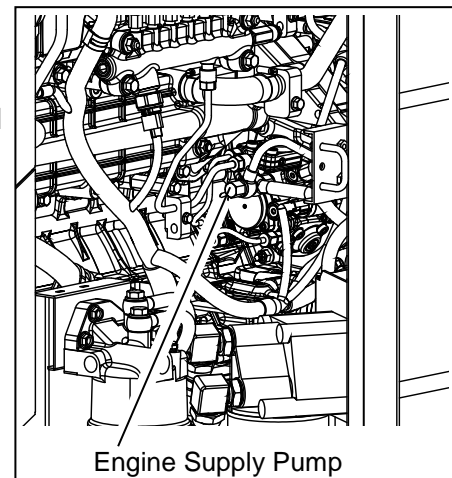

(10) Supply Module Filter Replacement

Replace	Every 2000 hours
---------	------------------

- 1 Place a container under Supply Module to catch spilled DEF.
- 2 Remove the filter cover using the socket wrench.
- 3 Pull out the Filter element and Equalizing element together.
- 4 Install the new Filter element and Equalizing element.
- 5 Tighten the Filter cover.

Filter cover tightening torque
20 - 25 N·m

< Note >

- Be careful not to screw the Filter Cover too tightly.
- After replacement, start the engine and check if there is no DEF leakage.
- Always be sure to wipe up any spilled DEF.
- The SCR continues to operate for approximately 3 minutes even after the starter switch is set to the "OFF" position. Wait for 3 minutes or more until the supply module stops operating.
- Discharged DEF is not reusable. Reuse may result in failure of the SCR.
- When disposing of discharged DEF, comply with regulations.
- Clean the filter by wiping it with clean cloth. Refrain from using high-pressure air to avoid foreign material blown by air coming in DEF pipe, which results in SCR failure.
- Supply module filter element (Including equalizing element) part no.: 8981694030 (Isuzu part no.)
- Socket wrench complies with ISO 2725-1

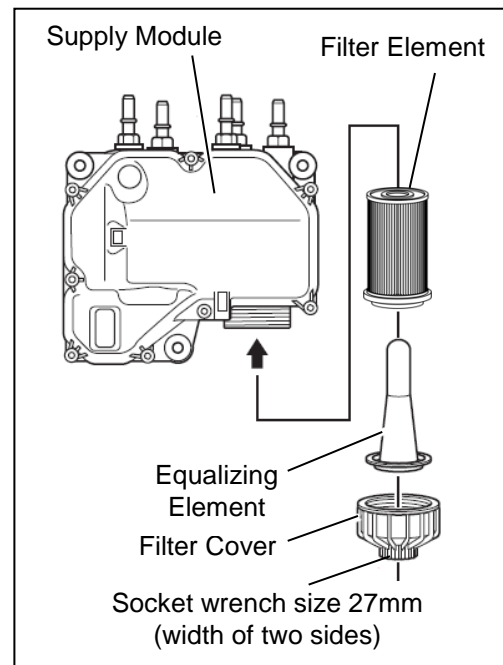

(11) Draining Water from the Fuel Tank

Drain Water	Every 250 hours
-------------	-----------------

- 1 Set a container to catch spilled water.
- 2 Remove the outer plug and the fuel drain plug.
- 3 Apply sealant coating to the plug or wrap it in seal tape.
- 4 After the water has been drained, reinsert the fuel drain plug.

< Note >

- After reinserting the fuel drain plug, be sure to always check that there is no fuel leakage.

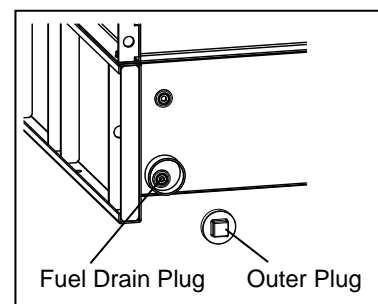

(12) Coolant Replacement

Replace	Every 1000 hours or every 1 year
---------	----------------------------------

- 1 Set a container to catch spilled coolant.
- 2 Remove the radiator plate.
- 3 Remove the radiator cap.
- 4 Remove the radiator coolant drain plug.
- 5 Loosen the engine coolant drain plug.
- 6 Apply sealant coating to the radiator coolant drain plug or wrap it in seal tape.
- 7 After the coolant has been drained, tighten the coolant drain plug.
- 8 Remove the sub-tank and flush the coolant from the sub-tank.
- 9 Reattach the sub-tank to its original position and fill with coolant until it reaches the FULL level.
- 10 Fill the radiator with coolant until it reaches the filler neck.
- 11 Re-attach and tighten the radiator cap.
- 12 Attach the radiator plate.

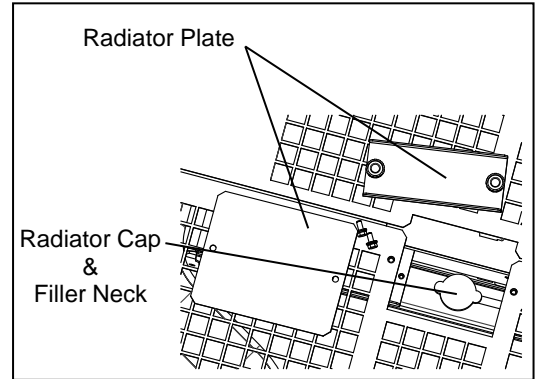

< Note >

- After reinserting the coolant drain plug and shortly after starting the engine, be sure to always check that there is no coolant leakage.

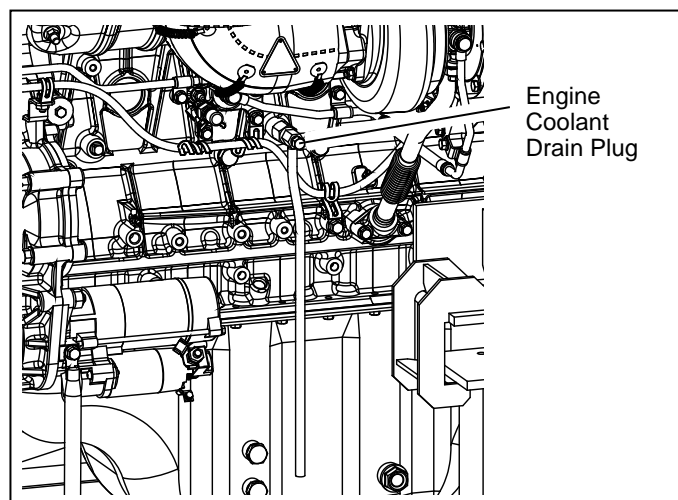
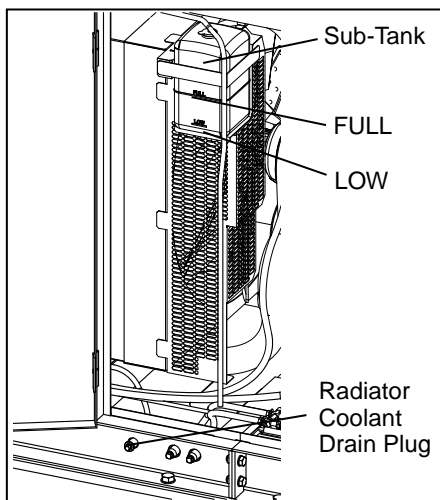

(13) Bleeding air from EGR cooler

Bleeding air	Every after coolant change
--------------	----------------------------

- 1 Loosen the air bleeder plug of the EGR cooler in order to bleed air from within the EGR and improve cooling performance.
- 2 When coolant flows out from the air bleeder plug, tighten the air bleeder plug.

Air bleeder plug tightening torque
19 - 25 N·m

< Note >

- When the air bleeder plug of the EGR cooler has been loosened, make sure to replace the packing with a new one..
- Air bleeder packing part no.: 9095714100 (Isuzu part no.)
- After tighten the air bleeder plug of the EGR cooler, be sure to always check that there is no leakage.

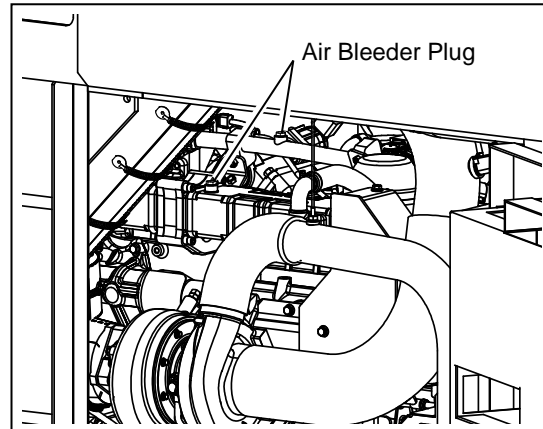

(14) Draining Water and Oil from the Intercooler

Drain Water	Every 500 hours
-------------	-----------------

- 1 Set a container to catch spilled water and oil.
- 2 Remove the drain plug.
- 3 After the water and oil has been drained, reinsert the drain plug.

< Note >

- After reinserting the drain plug, be sure to always check that there is no leakage.

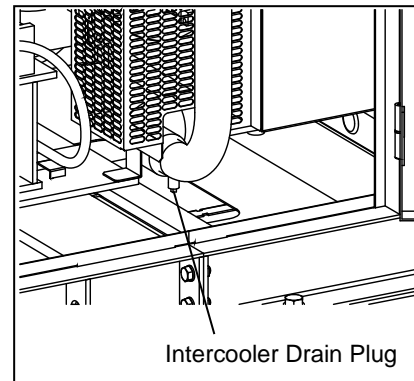

(15) Flushing Liquid in Spill Containment

Check	Daily
-------	-------

- 1 Set a container to collect liquid from the flushing port of the drain plug on the front of this generator.
- 2 Remove the drain plug.

< Note >

- If oil or other liquid is mixed in with the flushed liquid, this indicates that there is an oil leak. In such case, check for the leak location.
- The types of liquids that can accumulate in the spill containment include oil, fuel, coolant water, battery fluid, DEF such that it is not possible to distinguish between rain water and other liquids. Dispose of flushed liquids according to the related Federal laws and regulations.

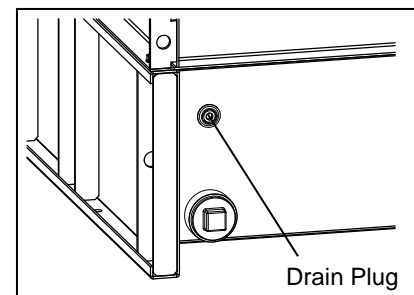

- 3 Apply sealant coating to the plug or wrap it in seal tape.
- 4 After the liquid has been flushed, and reinsert the fuel drain plug.

(16) Elimination of excessive carbon in the exhaust system by extensive light load



WARNING : EXHAUST GAS POISONING



- Do not operate the generator in poorly ventilated areas such as indoors or tunnels, as the exhaust gas of the engine contains substances that are harmful to human health.
- Do not direct exhaust fumes at bystanders or buildings.



WARNING : INJURY



- Always be sure to check that the breakers on load side and switches for any equipment using the generator are at OFF before turning the breaker to ON. Also be sure to advise personnel on the load side that power will be turned on before operating the breaker.
- Close all doors and lock them during operation.



CAUTION : FIRE



- Do not carry flammable items (such as fuel, gas and paint) or items that are highly combustible near the generator as the muffler, exhaust gas and other parts become extremely hot.
- Position this generator 3 ft. (1 m) or more from walls or other hindrances, and on a level surface.



CAUTION : INJURY

- Do not operate the generator if it has been modified or any parts have been removed.
- Position the generator on a level stable surface so that it cannot slide or move in any manner.
- Before starting operation, always be sure to turn off all switches of equipment being used and all breakers to OFF.

Clean	Every 250 hours
-------	-----------------

Accumulation of carbon (soot, unburned fuel) in the exhaust system could cause engine output loss and/or engine fault. To eliminate soot and unburned fuel, run the unit at more than 70% of the rated output for about half an hour, until the exhaust gas become mostly colorless. The carbon will accumulate when the unit runs at less than 30% of rated output.

< Note >

- When the unit runs at rated power suddenly, accumulation of carbon in the exhaust system might cause back fire incident. Operate the generator starting from 50% of the rated output and then increase load gradually after confirming exhaust gas become colorless. Do not carry flammable items that are highly combustible near the generator.

(17) Cleaning the Rear Cover

⚠ CAUTION : BURNS

- Do not touch the SCR system and surrounding components immediately after stopping the engine as they are still extremely hot.

⚠ CAUTION : INJURY

- Position the generator on a level stable surface so that it cannot slide or move in any manner.
- Before starting operation, always be sure to turn off all switches of equipment being used and all breakers to OFF.

Check/Clean	Every 500 hours
-------------	-----------------

There is a possibility that the drainage inside the rear cover is hindered by accumulation of dust and the like in the rear cover.

- 1 Remove the SCR check panel and Inspection/Cleaning panel of the rear cover.
- 2 Please check the inside of the rear cover and clean it if there is garbage.
- 3 Attach the SCR check panel and Inspection/Cleaning panel.

< Note >

- Do not open the SCR Check Panel and the Inspection/Cleaning Panel while the engine is running. When cleaning, be sure to run with the engine stopped.
- Please clean after SCR system temperature drops.
- When high-pressure cleaning inside the rear cover is performed, please make sure that the wiring connector of the SCR system and the electronic control device do not come into direct contact with water. Failure to observe this precaution will cause malfunction or malfunction.

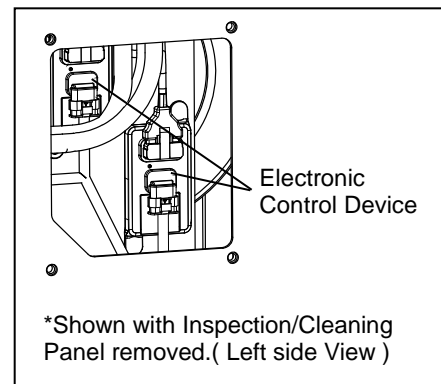
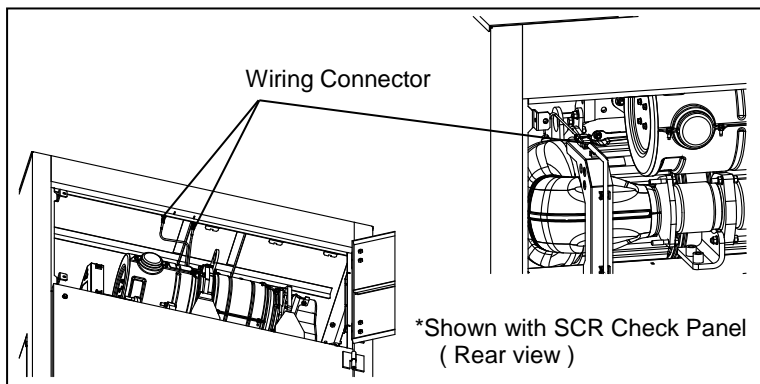
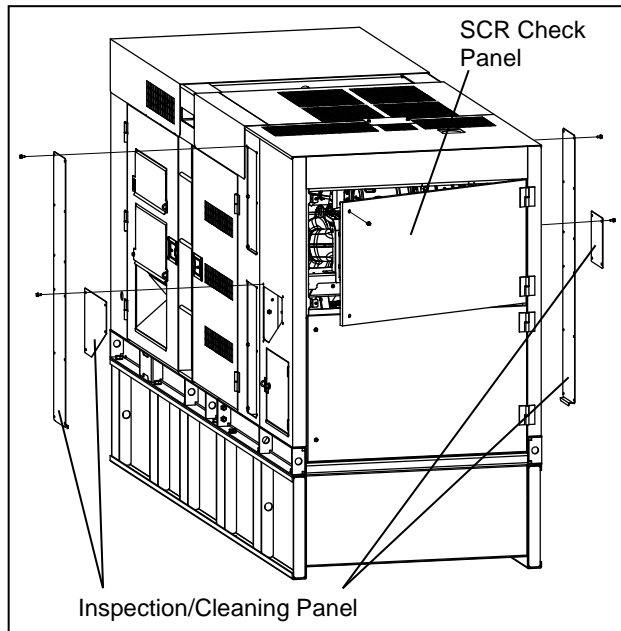

11. Long-Term Storage

WARNING : INJURY

- Always turn the starter switch to the STOP position and stop the engine, then close and lock OPERATION PANEL DOOR before checking or maintaining the engine or any equipment.

CAUTION : FIRE

- Always be sure to wipe up any spilled fuel or oil.
- Allow the generator to cool before covering with the protective cover.

CAUTION : BURNS

- Do not touch the engine and surrounding components immediately after stopping the engine as they are still extremely hot.

(1) Storage Procedures

Perform the following maintenance procedures before storing this generator if it is not going to be used for two months or more.

- 1 Remove the battery. (Refer to section “**8-8. Checking the Battery**”.)
- 2 Replace the engine oil.
(Refer to section “**10. Inspection/Maintenance (1) Engine Oil Replacement**”.)
- 3 Drain the fuel from the fuel tank and filter.
(Refer to section “**10. Inspection/Maintenance (5) Draining Water from the Fuel Filter (Pre Filter)**”.)
(Refer to section “**10. Inspection/Maintenance (11) Draining Water from the Fuel Tank**”.)
- 4 Drain the DEF from the DEF tank.
- 5 Clean up and inspect inside of the spill containment.
(Refer to section “**10. Inspection/Maintenance (15) Flushing Liquid in Spill Containment**”.)
- 6 Store in a secured location.
- 7 Clean up all generator components, and store in a dry and dust-free location. Also cover when storing so that rain cannot enter through the suction or exhaust ports.

< Note >

- Adjust the fluid of the removed battery to the appropriate level and recharge approximately every month.

(2) Double-Stacking Storage Procedures

WARNING : INJURY

Always be sure to observe the following items when double stacking this generator in a warehouse or similar location.

- Check that the hood of this generator is not dented, and that bolts are not loose or missing.
- Set in a location with a flat hard floor capable of withstanding the double-stacking weight.
- Always be sure to use lifting hooks when lifting this generator.
- Insert wood ties of the same size and that are wider than this generator between each generator, and set another generator on top of the ties.
- Never stack more than two levels, and do not set a generator on top that is larger in weight/size than that on the bottom.

Do not operate the generator when it is double stacked.

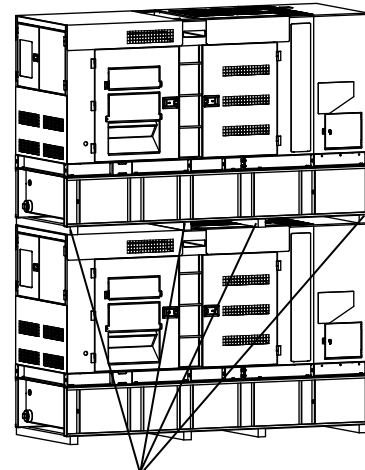

Insert wood ties

12. Troubleshooting

WARNING : ELECTRIC SHOCK / INJURY

- Do not touch output terminals or internal electric parts while the generator is operating.
- Do not open the check door when the starter switch is in the AUTO or START position. It will cause injury by rotating parts such as cooling fans and fan belt.
- Always turn the starter switch to the STOP position and stop the engine, then close and lock OPERATION PANEL DOOR before checking or maintaining the engine or any equipment.

CAUTION : FIRE

- Never allow flame to come closer to the generator.

CAUTION : BURNS

- Do not touch the engine and muffler after stopping the engine as they are still extremely hot.

Inspect this generator when operation is poor to determine the fault/malfunction.

Request the authorized distributor where the generator was purchased to perform maintenance if you cannot find any faults/malfunctions during inspection.

Problem		Suspected cause	Action
Engine does not start	Starter motor does not drive or speed is low	<ol style="list-style-type: none"> 1. Battery output is weak 2. Battery is deteriorated 3. Battery terminal is OFF or loose 4. Battery terminal is corroded 5. Starter switch or relay is defective 6. Starter motor is defective 7. ECM (Engine Controller) is defective 	<ol style="list-style-type: none"> 1. Check battery fluid or charge 2. Replace Battery 3. Fix/Tighten terminal 4. Clean terminal 5. Contact distributor or dealer for repair 6. Contact distributor or dealer for repair 7. Contact distributor or dealer for repair
	Starter motor drives but engine does not start	<ol style="list-style-type: none"> 1. Fuel is insufficient 2. Fuel filter is clogged 3. Water is interfused in fuel line 4. Air is interfused in fuel line 5. Mistake of connecting with external tank 6. Mistake of turning 3way fuel valve lever 7. Fuel pump defective 8. Emergency operation/Fault detection 	<ol style="list-style-type: none"> 1. Add fuel 2. Clean/Replace fuel filter 3. Drain water in fuel filter or fuel tank 4. Extract the air 5. Check fuel piping 6. Check 3way fuel valve 7-1. Check/Replace fuse 7-2. Check/Replace fuel pump 8. Contact distributor or dealer for repair
	<Ambient temperature falls down below 32°F (0°C) >	<ol style="list-style-type: none"> 1. Fuel is frozen 2. Water in fuel line is frozen 3. Pre-heater is defective 	<ol style="list-style-type: none"> 1. Use winterized fuel 2. Drain water in fuel line 3. Contact distributor or dealer for repair
Engine starts but stalls immediately	<ol style="list-style-type: none"> 1. Fuel filter is clogged 2. Water is interfused in fuel line 3. Air is interfused in fuel line 4. Mistake of connecting with external tank 5. Air filter element is clogged 6. Lubricant oil is insufficient 7. Emergency operation/Fault detection 	<ol style="list-style-type: none"> 1. Clean/Replace fuel filter 2. Drain water in fuel filter or fuel tank 3. Extract the air 4. Check fuel piping 5. Check/Replace air filter element 6. Add lubricant oil 7. Contact distributor or dealer for repair 	
Engine oil pressure is low	<ol style="list-style-type: none"> 1. Lubricant oil is insufficient 2. Oil filter is clogged 3. Oil Pressure switch is defective 4. Oil pressure meter is defective 5. Wrong oil is used 	<ol style="list-style-type: none"> 1. Add lubricant oil 2. Replace oil filter 3. Contact distributor or dealer for repair 4. Contact distributor or dealer for repair 5. Change to proper kind and viscosity oil 	
Overheated	<ol style="list-style-type: none"> 1. Engine thermostat is defective 2. Water temp sensor is defective 3. Water temp meter is defective 4. Fan belt tension is weak 5. Coolant is insufficient 6. Radiator core is clogged 	<ol style="list-style-type: none"> 1. Contact distributor or dealer for repair 2. Contact distributor or dealer for repair 3. Contact distributor or dealer for repair 4. Check/Adjust fan belt 5. Check/Add coolant 6. Clean radiator core 	
Black smoke comes out from Muffler	<ol style="list-style-type: none"> 1. Air filter element is clogged 2. Fuel injection nozzle is defective 3. Improper fuel is used 4. SCR system is faulty 	<ol style="list-style-type: none"> 1. Check/Change air filter element 2. Contact distributor or dealer for repair 3. Change to clean fuel 4. Contact distributor or dealer for repair 	

Problem	Suspected cause	Action
White smoke comes out from Muffler	<ol style="list-style-type: none"> 1. Too much or too little oil to cylinder 2. Water is interfused in fuel line 3. Fuel injection nozzle is defective 4. Coolant temperature is too low 5. Engine thermostat is defective 	<ol style="list-style-type: none"> 1. Contact distributor or dealer for repair 2. Drain water in fuel filter or fuel tank 3. Contact distributor or dealer for repair 4. Warm-up driving is needed 5. Contact distributor or dealer for repair
Pointer (hand) does not move in voltage meter	<ol style="list-style-type: none"> 1. Voltage meter is defective 2. AVR is defective 3. Disconnected circuit, loose terminal or departed 4. Initial exciter is defective 5. Alternator is defective 6. AVR protective device operation 	<ol style="list-style-type: none"> 1. Contact distributor or dealer for repair 2. Contact distributor or dealer for repair 3. Contact distributor or dealer for repair 4. Contact distributor or dealer for repair 5. Contact distributor or dealer for repair 6. Replace AVR fuse
Pointer (hand) does not goes up to the rated voltage	<ol style="list-style-type: none"> 1. Voltage meter is defective 2. AVR is defective 3. Voltage regulator dial is defective 	<ol style="list-style-type: none"> 1. Contact distributor or dealer for repair 2. Contact distributor or dealer for repair 3. Contact distributor or dealer for repair
Pointer exceeds the rated voltage	<ol style="list-style-type: none"> 1. Voltage meter is defective 2. AVR is defective 3. Improper load cable connection 4. Voltage switch is set to 480 V 	<ol style="list-style-type: none"> 1. Contact distributor or dealer for repair 2. Contact distributor or dealer for repair 3. Correctly set the connection location to the receptacle 4. Set the voltage switch to 240 V
The voltage drops drastically when connecting to load	<ol style="list-style-type: none"> 1. AVR is defective 2. Unbalanced loads sharing to each terminal 3. The current of the used equipment exceeds the rated current 4. Over load 5. AVR protective device operation 	<ol style="list-style-type: none"> 1. Contact distributor or dealer for repair 2. Balance the loads sharing to each terminal 3. Change to a device with an available capacity 4. Decrease the loads to meet the rated output 5. Replace AVR fuse
Cannot turn the breaker to ON	<ol style="list-style-type: none"> 1. The Main breaker positions at between ON and OFF 2. Short circuit on the load 	<ol style="list-style-type: none"> 1. Once turning the lever to OFF, turn it to ON 2. Check the load circuit

13. Generator Circuit Diagram

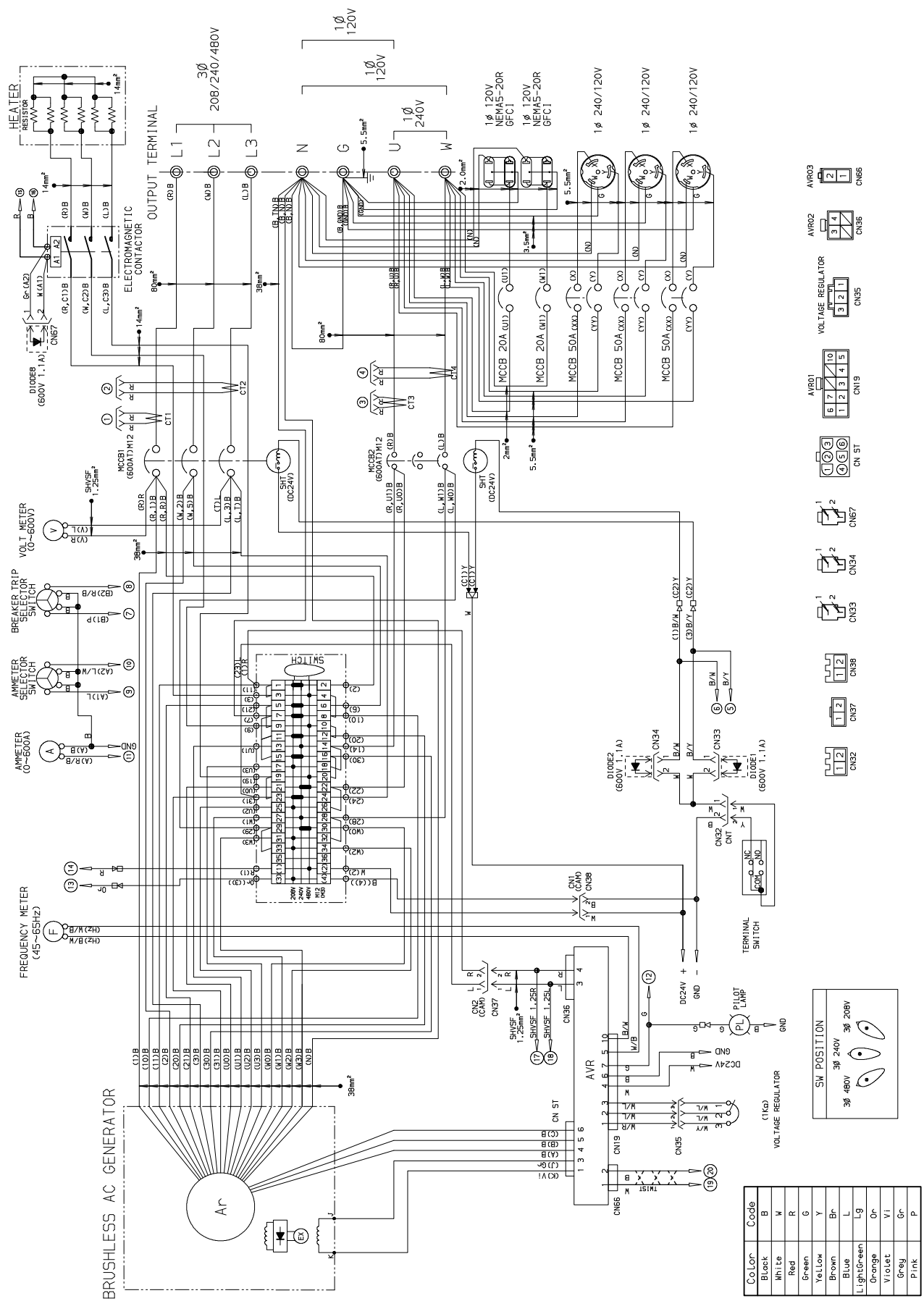

Color	Code
Black	B
White	W
Red	R
Green	G
Yellow	Y
Brown	Br
Blue	L
LightGreen	Lg
Orange	Or
Violet	Vi
Grey	Gr
Pink	P

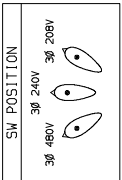

14. Engine Electrical Circuit Diagram

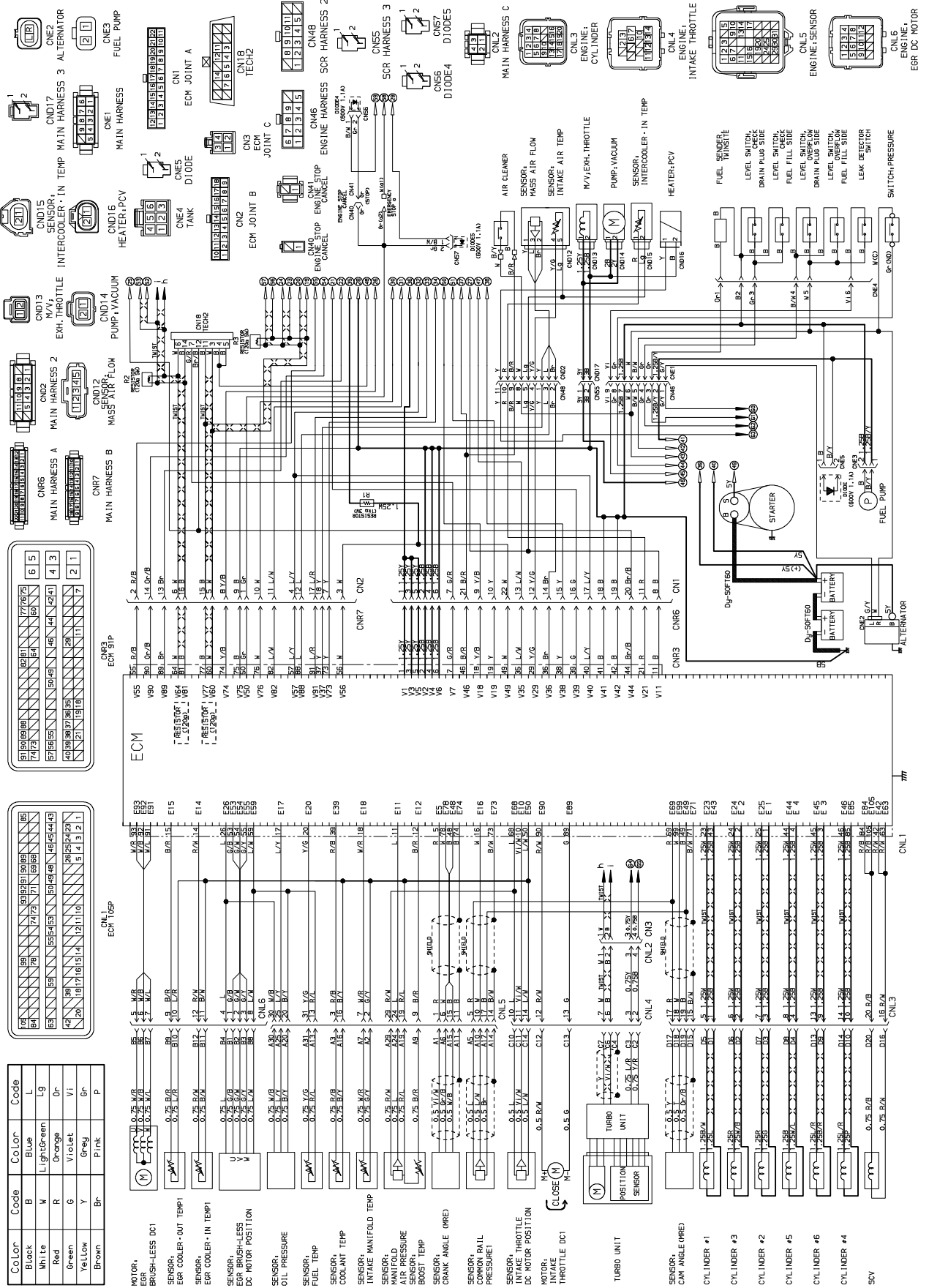

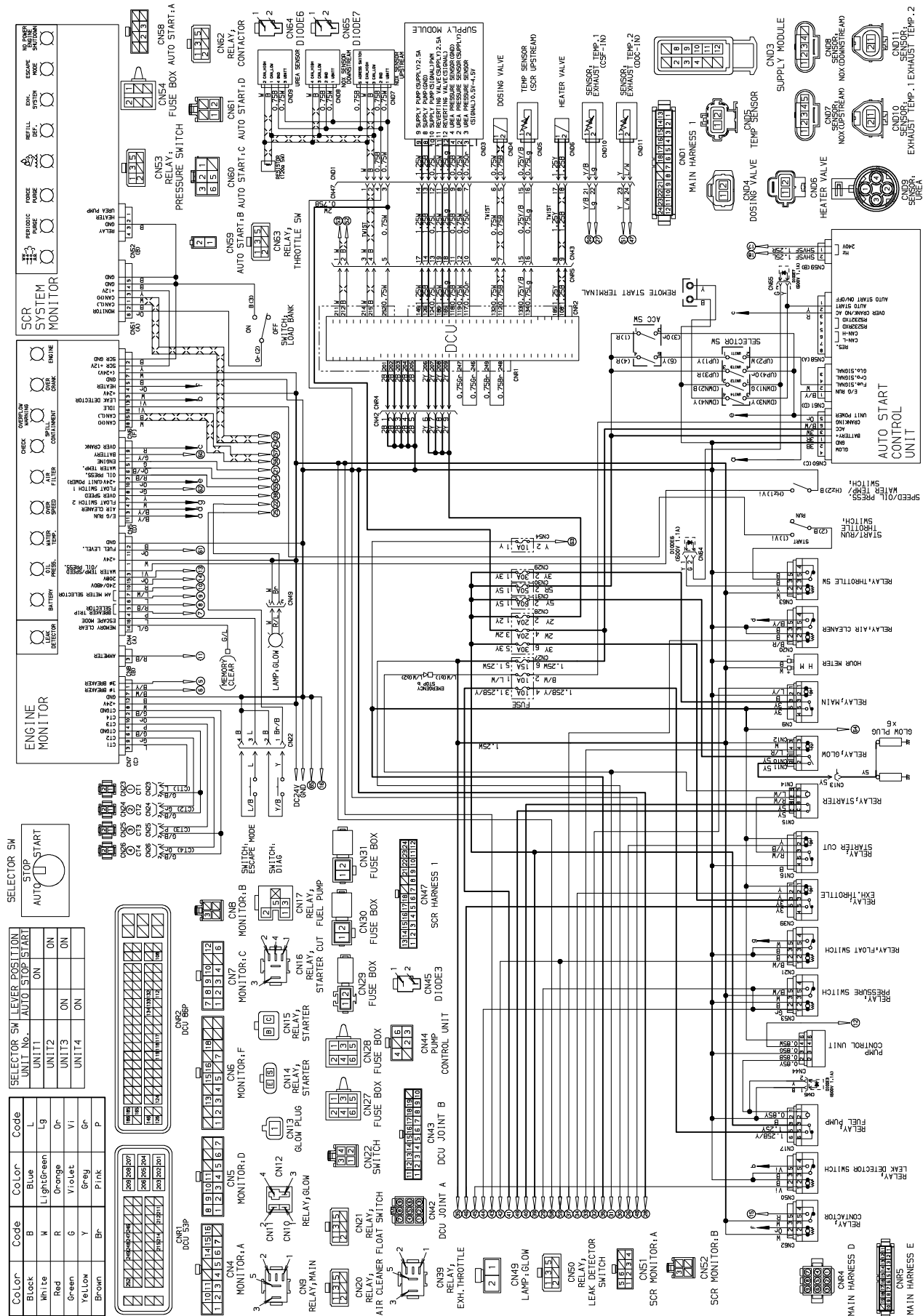

Code	Color	Code	Color
B	Black	L	Blue
H	White	Lg	Light Green
R	Red	Or	Orange
G	Green	Vi	Violet
Y	Yellow	Gr	Grey
Br	Brown	P	Pink



YAMABIKO CORPORATION
7-2 SUEHIROCHO 1-CHOME, OHME, TOKYO 198-8760, JAPAN
PHONE: 81-428-32-6118. FAX: 81-428-32-6145.

shindaiwa[®]