



# Power Edger

## *Operator's Manual*

**MODEL PE-310**

**Serial Number 03001001 - 03002099**

**WARNING**  **DANGER**



The muffler or catalytic muffler and surrounding cover may become extremely hot.

Always keep clear of exhaust and muffler area, otherwise serious personal injury may occur.

 **WARNING** 

The engine exhaust from this product contains chemicals known to the State of California to cause cancer, birth defects or other reproductive harm.



**WARNING**  **DANGER**

Read rules for safe operation and instructions carefully. ECHO provides an Operator's Manual and a Safety Manual. Both must be read and understood for proper and safe operation.

## INTRODUCTION

Welcome to the ECHO family. This ECHO product was designed and manufactured to provide long life and on-the-job dependability. Read and understand this manual, and the SAFETY MANUAL you found in the same package. You will find both easy to use, and full of helpful operating tips and SAFETY messages.

### THE OPERATOR'S MANUAL

Read and understand this manual before operation. Keep it in a safe place for future reference. Contains specifications and information for operation, starting, stopping, maintenance, storage and assembly specific to this product.

### THE SAFETY MANUAL

Read and understand this manual before operation. Keep it in a safe place for future reference. Explains possible hazards involved with the use of Edgers and the measures you should take to make their use safer.



## TABLE OF CONTENTS

Introduction .....	2	- Operating Techniques .....	14
- The Operator's Manual .....	2	Maintenance .....	15
- The Safety Manual .....	2	- Skill Levels .....	15
Manual Safety Symbols and Important Information ..	3	- Maintenance Intervals .....	15*
Safety .....	3	- Air filter .....	16
- Decals .....	3	- Fuel Filter .....	16
- International Symbols .....	4	- Spark Plug .....	17
Safety Instructions .....	4	- Cooling System .....	17
- Personal Condition and Safety Equipment .....	4	- Exhaust System .....	18
- Extended Operation/Extreme Conditions .....	5	- Carburetor Adjustment .....	19
- Equipment .....	5	- Lubrication .....	19*
- Safe Operation .....	6	- Blade Replacement .....	20
Emission Control .....	6	Troubleshooting .....	21
Description .....	7*	Storage .....	22
- Contents .....	7*	Servicing Information .....	24
Assembly .....	9	- Parts .....	24
- Specifications .....	9*	- Service .....	24
- Drive Shaft/Power Head .....	10	- Echo Consumer Product Support .....	24
- Throttle Linkage and Ignition Leads .....	10	- Warranty Card .....	24
- Front Handle .....	11	- Additional or Replacement Manuals .....	24
Pre-Operation .....	11	* Supplement to Operator's Manual .....	25
- Fuel .....	11		
Operation .....	12		
- Starting Cold Engine .....	12		
- Starting Warm Engine .....	13		
- Stopping Engine .....	13		

Specifications, descriptions, and illustrative material in this literature are as accurate as known at the time of publication, but are subject to change without notice. Illustrations may include optional equipment and accessories, and may not include all standard equipment.

## MANUAL SAFETY SYMBOLS AND IMPORTANT INFORMATION

Throughout this manual and on the product itself, you will find safety alerts and helpful information messages, preceded by symbols or key words. The following is an explanation of those symbols and key words.



This symbol accompanied by the words **WARNING** and **DANGER** calls attention to an act or condition that can lead to serious personal injury to operator and bystanders.



The circle with the slash symbol means whatever is shown within the circle is prohibited.



### IMPORTANT

The enclosed message provides information necessary for the protection of the unit.

### NOTE

This enclosed message provides tips for use, care and maintenance of the unit.

## SAFETY

### DECALS

Locate these safety decals on your unit. The complete unit illustration found in the "DESCRIPTION" section, will help you locate them. Make sure the decals are legible and that you understand and follow the symbols and instructions on them. If a decal cannot be read, a new one can be ordered from your ECHO Dealer. See PARTS ORDERING instructions for specific information.

These decals are in English only:

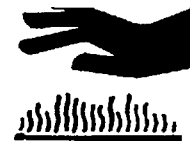

P/N 89016006361

### Shaft Decal

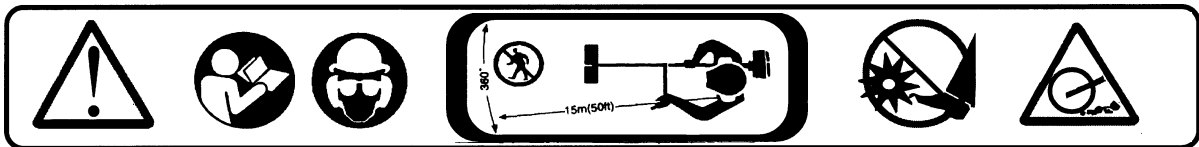

P/N 89016025560

### - WARNING - DANGER -

• When used improperly this edger could cause serious personal injury. Read and follow all safety precautions in the owner's manual. • Never operate without eye protection. • Always inspect area for hidden or throwable objects. Never use in gravel. • Stay clear of rotating blade at all times. Keep bystanders at least 50' away. • Stop engine before adjusting cutting height or performing any service. • Never operate with unit positioned on left side of body. • Use only ECHO approved replacement blades on this unit. • Do not use edger blade on any brush cutter. • Edger attachment and blade are intended for edging only. • After replacing or servicing blade, arbors, nut and cotter pins must be assembled properly. P/N 89016052631

P/N 89016052631

## INTERNATIONAL SYMBOLS

Symbol form/ shape	Symbol description/ application	Symbol form/ shape	Symbol description/ application
	Read and understand Operator's Manual.		Fuel and oil mixture
	Wear eyes, ears and head protection		Finger Severing
	Hot Surface		Wear hand protection. Use two handed.
	Safety/Alert		DO NOT smoke near fuel.
	Avoid all power lines. This unit is not insulated against electrical current.		DO NOT allow flames or sparks near fuel.
		Keep bystanders away 15 m (50 ft.)	

Symbol form/ shape	Symbol description/ application	Symbol form/ shape	Symbol description/ application
	Keep feet away from blade		Direction of blade
	Thrown objects		Emergency stop
	Wear slip resistant foot wear.		Engine choke control.
	Primer bulb		Ignition ON/OFF
	Carburetor adjustment - High speed mixture		Carburetor adjustment - Idle speed
	Carburetor adjustment - Low speed mixture		

## SAFETY INSTRUCTIONS

### PERSONAL CONDITION AND SAFETY EQUIPMENT

## WARNING DANGER

Edger users risk injury to themselves and others if the edger is used improperly and or safety precautions are not followed. Proper clothing and safety gear must be worn when operating an edger.

### *Eye Protection*

Wear eye protection that meets ANSI Z87.1 or CE requirements whenever you operate the edger.

### *Hand Protection*

Wear no-slip, heavy duty work gloves to improve your grip on the edger handles. Gloves also reduce the transmission of machine vibration to your hands.

### *Hearing Protection*

ECHO recommends wearing hearing protection whenever unit is used.

### *Proper Clothing*

Wear snug fitting, durable clothing;

- Pants should have long legs, shirts with long sleeves.
- DONOTWEARSHORTS,
- DONOTWEARTIES,SCARVES,JEWELRY.

Wear sturdy work shoes with non-skid soles;

- DONOTWEAROPENTOEDSHOES,
- DONOTOPERATEUNITBAREFOOTED.

### *Hot Humid Weather*

Heavy protective clothing can increase operator fatigue which may lead to heat stroke. Schedule heavy work for early morning or late afternoon hours when temperatures are cooler.

## EXTENDED OPERATION/EXTREME CONDITIONS

### *Vibration and Cold*

It is believed that a condition called Raynaud's Phenomenon, which affects the fingers of certain individuals, may be brought about by exposure to vibration and cold. Exposure to vibration and cold may cause tingling and burning sensations, followed by loss of color and numbness in the fingers. The following precautions are strongly recommended, because the minimum exposure which might trigger the ailment is unknown.

- Keep your body warm, especially the head, neck, feet, ankles, hands, and wrists.
- Maintain good blood circulation by performing vigorous arm exercises during frequent work breaks, and also by not smoking.
- Limit the hours of operation. Try to fill each day with jobs where operating the edger or other hand-held power equipment is not required.
- If you experience discomfort, redness and swelling of the fingers, followed by whitening and loss of feeling, consult your physician before further exposing yourself to cold and vibration.

### *Repetitive Stress Injuries*

It is believed that overusing the muscles and tendons of the fingers, hands, arms, and shoulders may cause soreness, swelling, numbness, weakness, and extreme pain in those areas. Certain repetitive hand activities may put you at a high risk for developing a Repetitive Stress Injury (RSI). An extreme RSI condition is Carpal Tunnel Syndrome (CTS), which could occur when your wrist swells and squeezes a vital nerve that runs through the area. Some believe that prolonged exposure to vibration may contribute to CTS. CTS can cause severe pain for months or even years.

To reduce the risk of RSI/CTS, do the following:

- Avoid using your wrist in a bent, extended, or twisted position. Instead, try to maintain a straight wrist position. Also, when grasping, use your whole hand, not just the thumb and index finger.
- Take periodic breaks to minimize repetition and rest your hands.
- Reduce the speed and force with which you do the repetitive movement.
- Do exercises to strengthen the hand and arm muscles.
- Immediately stop using all power equipment and consult a doctor if you feel tingling, numbness, or pain in the fingers, hands, wrists, or arms. The sooner RSI/CTS is diagnosed, the more likely permanent nerve and muscle damage can be prevented.

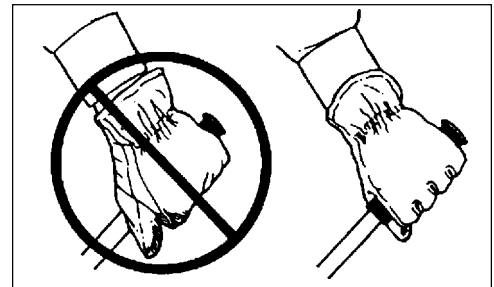

## EQUIPMENT

- Check unit for loose/missing nuts, bolts and screws. Tighten and/or replace as needed.
- Inspect fuel lines, tank, and area around carburetor for fuel leaks. DO NOT operate unit if leaks are found.
- Inspect shield for damage, and that shield is **securely** in place. Replace if shield is damaged or missing.
- Check that the cutting attachment is firmly attached and in safe operating condition.
- Check that front handle is adjusted for safe, comfortable operation. See Assembly for proper adjustment.
- Keep exhaust area clear of flammable debris. Avoid contact during and immediately after operation.

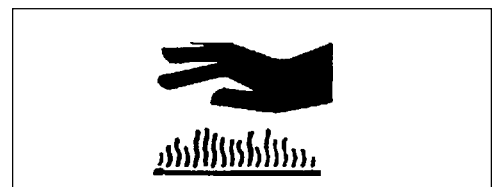

## SAFE OPERATION

### WARNING DANGER

Do not operate this product indoors or in inadequately ventilated areas. Engine exhaust contains poisonous emissions and can cause serious injury or death.

#### Provide Operating And Safety Instructions To All Operators

- Provide all operators of this equipment with the Operator's Manual and Safety Manual for instructions on safe operation.

#### Keep A Firm Grip

- Hold the front and center or rear and center handles with both hands, with thumbs and fingers tightly encircling the handles

#### Keep A Solid Stance

- Maintain footing and balance at all times. Do not stand on slippery, uneven or unstable surfaces. Do not work in odd positions or on ladders. Do not over-reach.

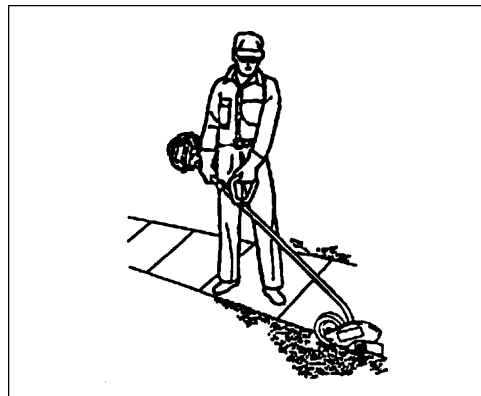

## EMISSION CONTROL

### *EPA Phase II*

The emission control system for these engines is EM (Engine Modification).

#### IMPORTANT ENGINE INFORMATION

ENGINE FAMILY: 2EHXS.0314EA DISPLACEMENT: 30.5 cc  
EMISSION COMPLIANCE PERIOD: 300 HRS.  
THIS ENGINE MEETS U.S. EPA PHASE II EMISSION REGULATIONS FOR SMALL NONROAD ENGINES. REFER TO OWNER'S MANUAL FOR MAINTENANCE SPECIFICATIONS AND ADJUSTMENTS.



**KORITZ CORP.** 

An Emission Control Label is located on the engine. (This is an EXAMPLE ONLY, information on label varies by engine FAMILY).

#### PRODUCT EMISSION DURABILITY

The 300 hour emission durability compliance period is the time span selected by the manufacturer certifying the engine emissions output meets applicable emissions regulations, provided that approved maintenance procedures are followed as listed in the Maintenance Section of this manual.

## DESCRIPTION

The ECHO product you purchased has been factory pre-assembled for your convenience. Due to packaging restrictions, shield installation and positioning of the front handle are necessary.

After opening the carton, check for damage. Immediately notify your retailer or ECHO Dealer of damaged or missing parts. Use the contents list to check for missing parts.

## CONTENTS

- 1 Edger Assembly
- 1 Power Head
- 1 Drive Shaft Assembly
- 1 Plastic Bag (Co-Pack)
- 1 Operator's Manual
- 1 Safety Manual
- 1 Warranty Registration Card
- 1 ECHO Emissions and Warranty Statement
- 1 50:1 1 Gal. ECHO Oil Mix
- 1 Front Handle
- 4 5 X 35 mm screws
- 4 5 mm nuts
- 1 Srench (Combination Spark Plug Socket/Screwdriver)
- 1 Cotter pin pak (10) 2mm x 25mm
- 1 4 mm Hexagon Wrench
- 1 Locking Tool
- 1 8 mm x 10 mm Open-end Wrench
- 1 Safety Glasses

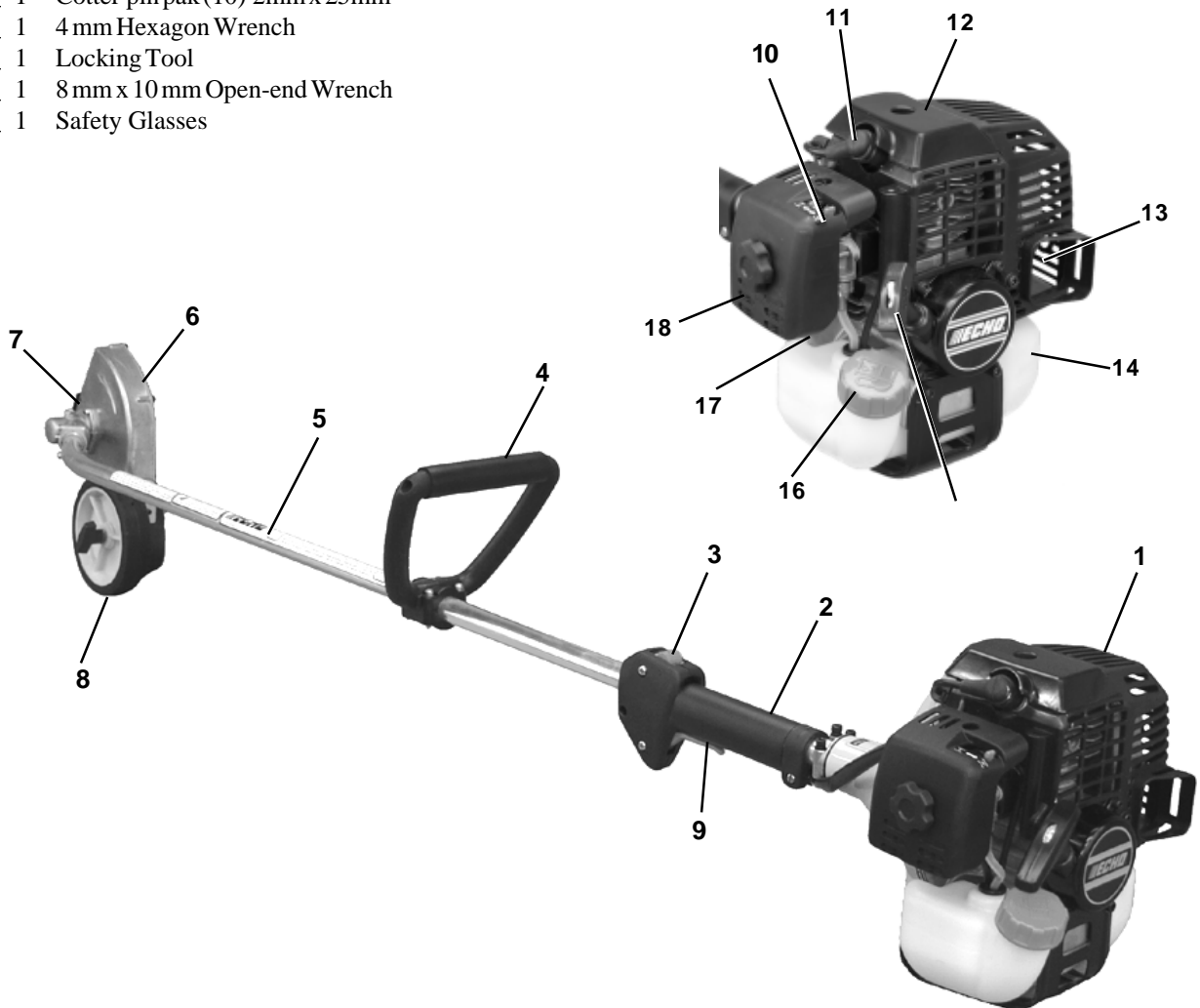
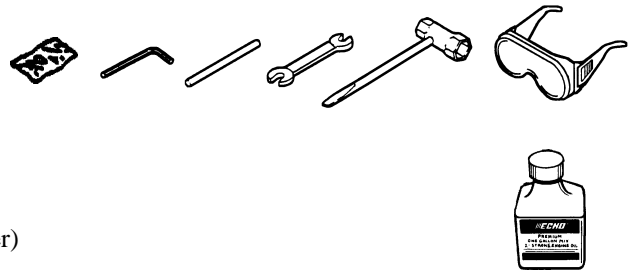
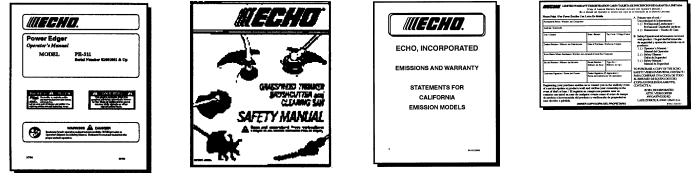

1. **POWER HEAD** - Includes the Engine, Clutch, Fuel System, Ignition System, and Recoil Starter.
2. **GRIP** - Rear (right hand) handle.
3. **STOP SWITCH** - "SLIDE SWITCH" mounted on top of the Throttle Trigger Housing. Move switch FORWARD to RUN, BACK to STOP.
4. **FRONT HANDLE** - The Front (loop) handle is factory assembled to the Drive Shaft Assembly and must be positioned for proper cutting position and operator comfort.
5. **DRIVE SHAFT ASSEMBLY** - Includes the Rear (right hand) Handle assembly, Gear Housing assembly, Front (loop, left hand) Handle assembly, Flexible Drive Cable and Safety Decal.
6. **DEBRIS SHIELD/FLAP** - Mounted over the cutting attachment. Helps protect operator by deflecting debris produced during the edging operation.
7. **BLADE** - Rotates to provide cutting action.
8. **WHEEL** - Adjustable up/down, sets depth of blade.
9. **THROTTLE TRIGGER** - Spring loaded to return to idle when released. During acceleration, press trigger gradually for best operating technique.
10. **CHOKE** - The choke control is located on the top of the air filter case. Move choke lever to "Cold Start" to close choke for cold starting. Move choke lever to "Run" position to open choke.
11. **SPARK PLUG** - Provides spark to ignite fuel mixture.
12. **TOP GUARD** - Protects arm from the hot engine.
13. **SPARK ARRESTOR - CATALYTIC MUFFLER/MUFFLER** - The muffler or catalytic muffler controls exhaust noise and emission. The spark arrestor screen prevents hot, glowing particles of carbon from leaving the muffler. Keep exhaust area clear of flammable debris.
14. **FUEL TANK** - Contains fuel and fuel filter.
15. **RECOIL STARTER HANDLE** - Pull handle slowly until starter engages, then pull quickly and firmly. When engine starts, return handle slowly. DO NOT let handle snap back, or damage to unit will occur.
16. **FUEL TANK CAP** - Covers and seals fuel tank opening.
17. **PRIMER BULB** - Pumping primer bulb before starting engine draws fresh fuel from the fuel tank, priming the carburetor for starting. Pump primer bulb until fuel is visible and flows freely in the clear fuel tank return line. Pump bulb an additional 4 or 5 times.
18. **AIR CLEANER** - Contains replaceable filter element.

**SPECIFICATIONS**

<b>MODEL</b> .....	<b>PE-310</b>
Length .....	1790mm(70.5in.)
Width .....	300mm(11.8in.)
Height .....	310mm(12.2in.)
Weight (dry w/cutter head) .....	7.2 kg (15.9 lb.)
Engine Type .....	Air cooled, two-stroke, single cylinder gasoline engine
Bore .....	36.0mm(1.42 in.)
Stroke .....	30.0mm(1.18 in.)
Displacement .....	30.5 cc (1.89 cu. in.)
Exhaust .....	Spark Arrestor Muffler
Carburetor .....	Walbro diaphragm model WYJ w/purge pump
Ignition System .....	Flywheel magneto, capacitor discharge (CDI)
Spark Plug .....	NGK BPM-8Y 0.65mm(0.026 in.)
Fuel .....	Mixed (Gasoline and Two-stroke Oil)
Fuel/Oil Ratio .....	50:1 ECHO High Performance, two-stroke air cooled engine oil
Gasoline .....	89 Octane unleaded. DO NOT use fuel containing methyl alcohol, more than 10% ethyl alcohol or 15% MTBE.
Oil .....	50:1 ECHO High Performance, two-stroke air cooled engine oil
Fuel Tank Capacity .....	0.8 lit. (27.1 US fl. oz.)
Starter System .....	Automatic Rewind Starter
Clutch .....	Centrifugal Type
Drive Shaft .....	1/4 in. flexible shaft
Rotation Direction .....	Clockwise viewed from side
Edger Head .....	Metal blade
Blade Length .....	203.2 mm(8.0 in.)
Blade Width .....	50.8 mm(2 in.)
Blade Thickness .....	4.5 mm(0.180 in.)
Handle .....	Left - D-loop, Right -Grip
Vibration Reduction .....	Rubber Cushion
Idle Speed .....	2500- 3300RPM
Wide Open Throttle Speed .....	9000- 11500RPM

## ASSEMBLY DRIVE SHAFT/POWER HEAD

*Tools Required:* 4mm Hex Wrench

*Parts Required:* Power head, Drive Shaft Assembly

1. Stand power head upright on a level surface.
2. Loosen the two (2) drive shaft clamp bolts at engine drive shaft clamp, and remove center drive shaft location bolt (A).
3. Carefully fit driveshaft assembly to engine making sure that inner drive shaft engages into clutch mount.
4. Turn drive shaft housing until locating hole lines up with location hole in clamp and install center drive shaft location bolt (A).

### NOTE

Gear Housing must be aligned properly with engine. Aligning center locating hole in driveshaft housing with center drive shaft bolt (A) provides correct alignment.

5. Tighten two (2) drive shaft clamp bolts (B) securely.

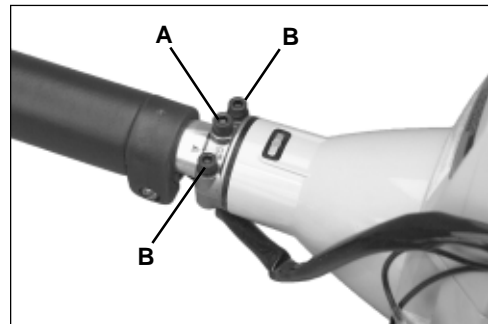
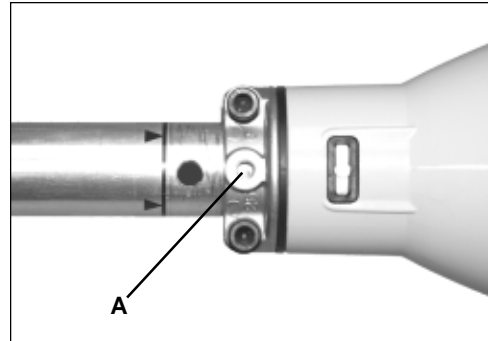

## THROTTLE LINKAGE AND IGNITION LEADS

*Tools Required:* 8 x 10 mm Open-end Wrench

*Parts Required:* None

1. Unscrew air filter cover knob and remove cover.
2. Place inner throttle cable in slot of carburetor swivel (B).
3. Loosen nut (A) and place threaded end of throttle linkage on carburetor. Finger tighten nut (A).
4. Check throttle for freedom of movement and that wide open throttle / low idle extremes are adjusted properly. If adjustment cannot be achieved with adjusting nuts, consult with your Echo Dealer for correct adjustment procedure.
5. Connect 2 ignition leads from throttle cable tubing to 2 ignition leads (C) on engine. Gather ignition wires, and position behind air filter case.

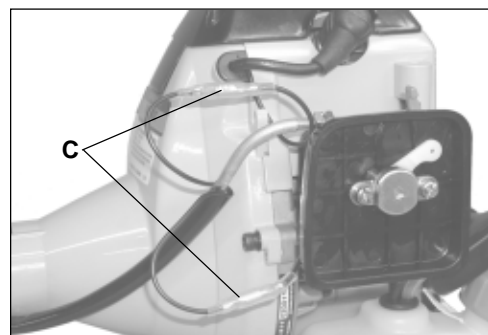
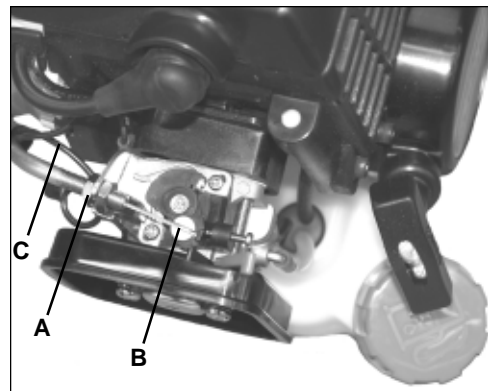

6. Install air filter and cover.

### FRONT HANDLE

*Tools Required:* Cross-Head Screwdriver

1. Assemble front handle and bracket loosely to drive shaft.
2. Position front handle in comfortable operating position and tighten screws.



## PRE-OPERATION

### FUEL

#### *Fuel Requirements*

**Gasoline** - Use 89 Octane [(R+M)/2] gasoline known to be good quality. Gasoline may contain up to 10% Ethanol (grain alcohol) or 15% MTBE (methyl tertiary-butyl ether). Gasoline containing methanol (wood alcohol) is **NOT** approved.

**Two-Stroke Oil - Two Stroke Oil** - A two-stroke engine oil meeting ISO-L-EGD (ISO/CD 13738) and J.A.S.O. FC Standards, must be used. Echo brand Premium 50:1 oil meets these standards. Engine problems due to inadequate lubrication caused by failure to use an ISO-L-EGD and J.A.S.O. FC certified oil, such as Echo Premium 50:1 Two-stroke Oil, will void the two-stroke engine warranty. (Emission related parts only are covered for two years, regardless of two-stroke oil used, per the statement listed in the Emission Defect Warranty Explanation.)

#### **IMPORTANT**

Echo Premium 2-Stroke Oil may be mixed at 50:1 ratio for application in all Echo engines sold in the past regardless of ratio specified in those manuals.

#### *Mixing Instructions*

1. Fill an approved fuel container with half of the required amount of gasoline.
2. Add 2-stroke oil to gasoline.
3. Close container and shake to mix oil with gasoline.
4. Add remaining gasoline and remix.
5. Install fuel container cap and wipe any spilled fuel from container and surrounding area.

#### *Handling Fuel*

### **WARNING** **DANGER**

Fuel is **VERY** flammable. Use extreme care when mixing, storing or handling, or serious personal injury may result.

- Use an approved fuel container.
- DO NOT smoke near fuel.
- DO NOT allow flames or sparks near fuel.
- Fuel tanks/cans may be under pressure. Always loosen fuel caps slowly allowing pressure to equalize.
- NEVER refuel a unit when the engine is HOT!
- NEVER refuel a unit with the engine running.
- DO NOT fill fuel tanks indoors. ALWAYS fill fuel tanks outdoors over bare ground.
- Securely tighten fuel cap after refueling.
- Inspect for fuel leakage. If fuel leakage is found, do not start or operate unit until leakage is repaired.

#### **IMPORTANT**

Spilled fuel is a leading cause of hydrocarbon emissions. Some states may require the use of automatic fuel shut-off containers to reduce fuel spillage. Contact your ECHO dealer for ordering information.

## After refueling

- Wipe any spilled fuel from the unit.
- Move at least 3 m (10 ft.) from refueling location before starting the engine.

## After use

- DO NOT store a unit with fuel in its tank. Leaks can occur. Return unused fuel to an approved fuel storage container.

## Storage

Fuel storage laws vary by locality. Contact your local government for the laws affecting your area. As a precaution, store fuel in an approved, air tight container. Store in a well ventilated, unoccupied building, away from sparks and flames. Do not store fuel longer than 30 days.

### IMPORTANT

Stored fuel ages. Do not mix more fuel than you expect to use in thirty (30) days, ninety (90) days when a fuel stabilizer is added.

### IMPORTANT

Stored two-stroke fuel may separate. ALWAYS shake fuel container thoroughly before each use.

## OPERATION

### STARTING COLD ENGINE

#### WARNING DANGER

The cutting attachment should not rotate at idle. If attachment rotates, readjust carburetor according to "Carburetor Adjustment" instructions in this manual or see your ECHO Dealer, otherwise serious personal injury may result.

1. *Stop Switch*  
Move stop switch button (A) forward away from the STOP position.
2. *Choke Lever*  
Move choke lever (B) to "Cold Start" Position.
3. *Primer Bulb*  
Pump primer bulb (C) until fuel is visible and flows freely in the clear fuel tank return line. Pump bulb an additional 4 or 5 times.
4. *Recoil Starter*  
Lay the trimmer on a flat clear area and pull the recoil starter handle (D) until engine fires (5 or 6 pulls).
5. *Choke Lever*  
After engine fires, move choke lever to "Run" position and pull recoil starter handle/rope (D) until engine starts and runs. Allow unit to warm up at idle for several minutes.

#### NOTE

If engine does not start with choke in "Run" position after 5 pulls, repeat instructions 4 and 5.

6. *Throttle Trigger*  
After engine warm-up, gradually depress throttle trigger to increase engine RPM to operating speed.

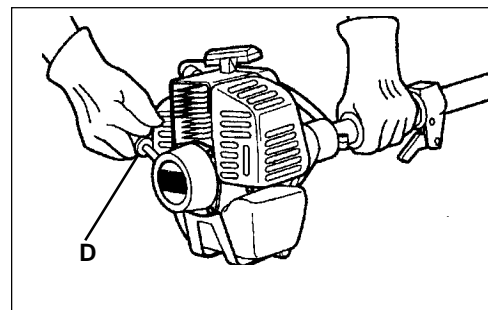
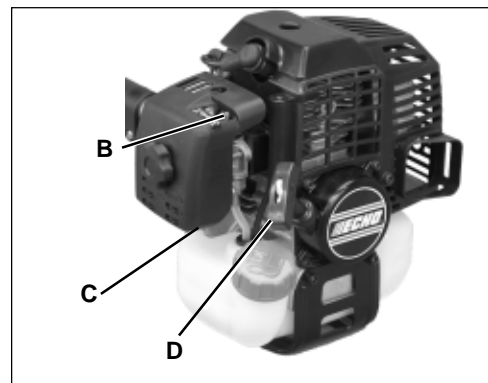
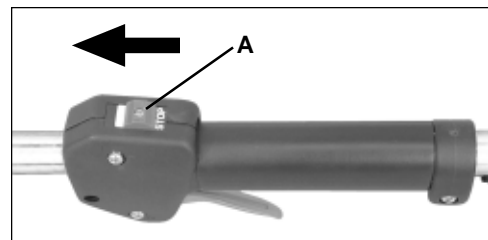

## STARTING WARM ENGINE

**WARNING**  **DANGER**

The cutting attachment should not rotate at idle. If attachment rotates, readjust carburetor according to "Carburetor Adjustment" instructions in this manual or see your ECHO Dealer, otherwise serious personal injury may result.

1. *Stop Switch*  
Move stop switch button (A) away from the STOP position.

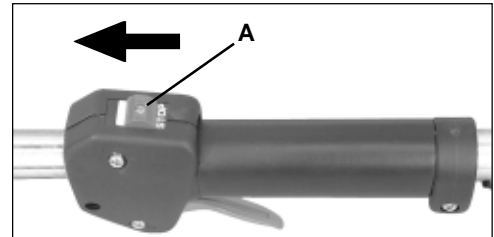

2. *Recoil Starter*  
Lay the trimmer on a flat clear area and pull the recoil starter handle (D) until the engine fires.

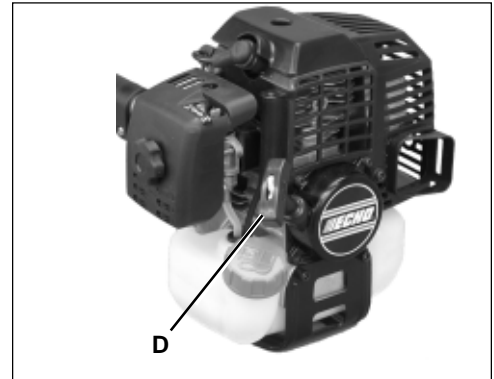

**NOTE**

If engine does not start after 5 pulls, use Cold Start Procedure.

## STOPPING ENGINE

1. *Throttle Trigger*  
Release throttle, and allow engine to idle for a minute.
2. *Stop Switch*  
Move stop switch button backward to STOP position.

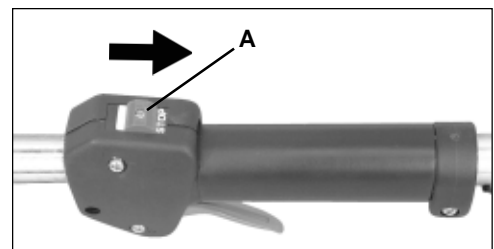

**WARNING**  **DANGER**

If engine does not stop when stop switch is moved to STOP position, close choke - COLD START position - to stall engine. Have your ECHO dealer repair stop switch before using trimmer again.

## OPERATING TECHNIQUES

1. Before edging, water the area to soften the ground to make edging easier.
2. Before edging, check the area and remove all obstacles and objects that could be thrown.
3. Plan to edge regularly to make it easier to keep a neat edge and to avoid having to make more than one pass.

### NOTE

Blade depth may have to be adjusted due to differences in height between the hard surface and the top of the grass.

### WARNING DANGER

Never adjust blade height with engine running, otherwise serious personal injury may result.

4. Adjust the blade's depth of cut to produce a fine cut between sidewalk and grass using a minimum blade depth, usually with about 1/2 in. of the blade into the ground.
5. Before edging, plan your direction of travel so that the unit will always be positioned on your right side and so that you walk on a hard surface whenever possible.
6. Hold edger as shown.

### WARNING DANGER

Before edging, be sure to read and understand the entire Operator's Manual to avoid the chance of serious injury.

7. When starting to edge, run the engine at full throttle, and lower the blade gently into the ground, being careful not to hit the concrete with the blade.
8. Don't force the blade. Only move forward as the blade will allow.

### WARNING DANGER

The complete unit, specifically the drive shaft assembly, may become very hot (too hot to touch) during use. Avoid contact during and immediately after operation, otherwise serious personal injury may result.

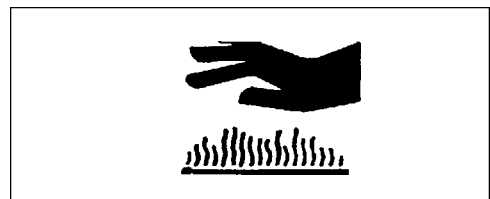
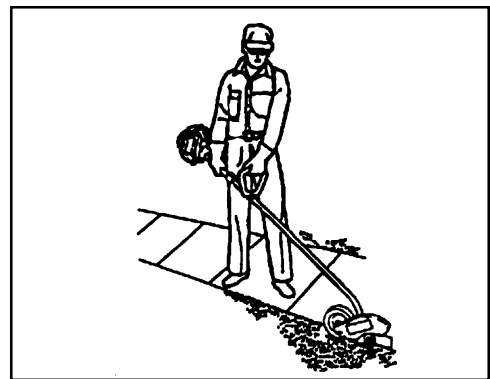
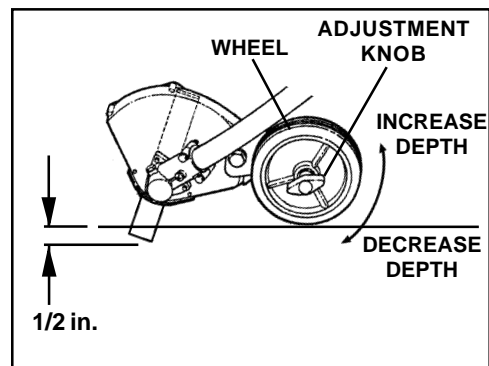

## MAINTENANCE

Your ECHO edger is designed to provide many hours of trouble free service. Regular scheduled maintenance will help your edger achieve that goal. If you are unsure or are not equipped with the necessary tools, you may want to take your unit to an ECHO Service Dealer for maintenance. To help you decide whether you want to DO-IT-YOURSELF or have the ECHO Dealer do it, each maintenance task has been graded. If the task is not listed, see your ECHO Dealer for repairs.

### SKILL LEVEL

- Level 1** = Easy to do. Most required tools come with unit.
- Level 2** = Moderate difficulty. Some specialized tools may be required.
- Level 3** = Experience required. Specialized tools are required. ECHO recommends that the unit be returned to your ECHO dealer for service.

ECHO offers **REPOWER™** Maintenance Kits and Parts to make your maintenance job easier. Just below each task heading are listed the various part numbers required for that task. See your ECHO dealer for these parts.

### MAINTENANCE INTERVALS

COMPONENT/ SYSTEM	MAINTENANCE PROCEDURE	REQ'D SKILL LEVEL	DAILY OR BEFORE USE	EVERY REFUEL	3 MONTHS OR 90 HOURS	6 MONTHS OR 270 HOURS	YEARLY 600 HOURS
<b>Recommended Echo Dealer Maintenance Procedures</b>							
Cylinder Exhaust Port	Inspect/Clean/Decarbon	3			I / C		
<b>Do-It-Yourself Maintenance Procedures</b>							
Air Filter	Inspect/Clean/Replace	1	I / C		R*		
Choke	Inspect/Clean	2	I / C				
Fuel Filter	Inspect/Replace	1			I		R *
Fuel System, leaks	Inspect/Replace	1	I	I / R *			
Cooling System	Inspect/Clean	2	I / C				
Muffler Spark Arrestor	Inspect/Replace	2	I / C		I / R*		
Drive Shaft	Grease	2			I (1)		
Gear Housing	Grease	2			I (2)		
Recoil Starter Rope	Inspect/Clean	1	I / C *				I / R*
Spark Plug	Inspect/Clean	2			I / C	R *	
Blade Replacement	Inspect/Replace	1	I	I	I / R*		
Screws/Nuts/Bolts	Inspect/Tighten/Replace	1	I / R *				

**MAINTENANCE PROCEDURE LETTER CODES:** I = INSPECT, R = REPLACE, C = CLEAN

**IMPORTANT NOTE** - Time intervals shown are maximum. Actual use and your experience will determine the frequency of required maintenance.

**MAINTENANCE PROCEDURE NOTES:**

(1) Apply ECHO® LUBE™ every 50 hours of use.

(2) Apply ECHO® LUBE™ every 15-25 hours of use.

\* All recommendations to replace are based on the finding of damage or wear during inspection..

## AIR FILTER

*Tools required:* 25-50 mm (1 or 2 in.) medium bristle paint brush.

*Parts required:* 90030REPOWER™ AIR & FUEL FILTER KIT.

1. Close choke (Cold Start Position). This prevents dirt from entering the carburetor throat when the air filter is removed. Brush accumulated dirt from the air cleaner area.
2. Remove the air cleaner cover. Clean and inspect the air filter for damage. If air filter is fuel soaked or very dirty, replace.
3. If air filter can be cleaned and reused, be certain it:
  - still fits the cavity in the air cleaner cover.
  - is installed with the original side out.

### NOTE

Carburetor adjustment may be needed after air filter cleaning or replacement.

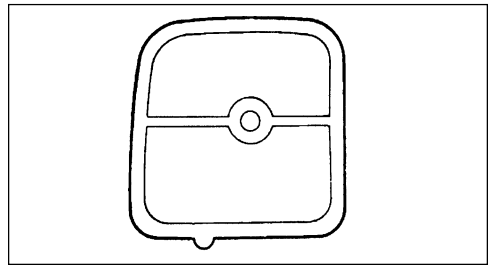
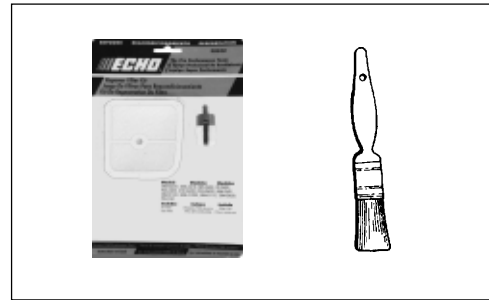

## FUEL FILTER

### Level 1.

*Tools required:* Fuel line hook, 200-250 mm (8-10 in.) length of wire with one end bent into a hook. Clean rag, funnel, and an approved fuel container.

*Parts required:* 90030REPOWER AIR & FUEL FILTER KIT

### WARNING DANGER

Fuel is **VERY** flammable. Use extreme care when mixing, storing or handling.

1. Use a clean rag to remove loose dirt from around fuel cap and empty fuel tank.
2. Use the “fuel line hook” to pull the fuel line and filter from the tank.
3. Remove the filter from the line and install the new filter.



## SPARK PLUG

### Level 2.

*Tools required:* Srench (combination socket wrench and screwdriver) and Feeler gauge (preferably a wire gauge), Soft Metal Brush

*Parts Required:* Spark Plug, NGKBPM-8YP/N15901019830

1. Remove spark plug and check for fouling, worn and rounded center electrode.
2. Clean the plug or replace with a new one. DO NOT sand blast to clean. Remaining sand will damage engine.
3. Adjust spark plug gap by bending outer electrode.
4. Tighten spark plug to 145-155 kg/cm (125-135 in. lb.).

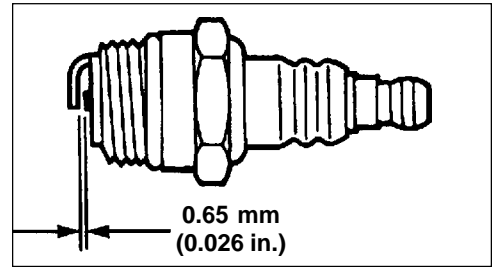
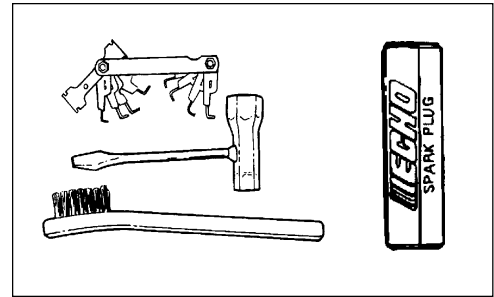

## COOLING SYSTEMS CLEANING

### Level 2.

*Tools required:* Cross Head Screwdriver, 4 mm Hex Wrench, Cleaning Brush, 25 or 50 mm (1 or 2 in.) medium bristle paint brush, Pointed Wood Stick.

*Parts Required:* None.

### IMPORTANT

To maintain proper engine operating temperatures, cooling air must pass freely through the cylinder fin area. This flow of air carries combustion heat away from the engine.

Overheating and engine seizure can occur when:

- Air intakes are blocked, preventing cooling air from reaching the cylinder.
- Dust and grass build up on the outside of the cylinder. This build up insulates the engine and prevents the heat from leaving.

Removal of cooling passage blockages or cleaning of cooling fins is considered "Normal Maintenance." Any failure attributed to lack of maintenance is not warranted.

1. Disconnect spark plug lead from spark plug.
2. Remove (3) screws from muffler cover, and remove cover.
3. Remove (3) screws from top guard, and remove guard.
4. Remove (1) screw from engine cover, and remove cover.

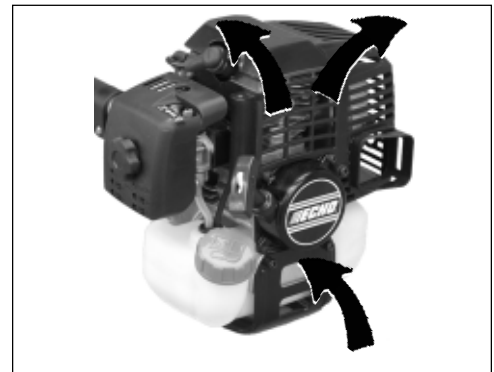
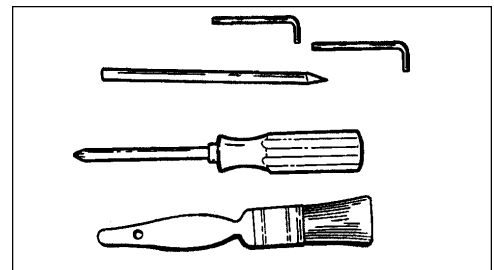

5. Use the wooden stick or brush to remove dirt from the cylinder fins.
6. Install engine cover, placing fuel vent tube into in engine cover.
7. Secure engine cover with one (1) screw.
8. Install top guard correctly and secure with three (3) screws (install long screw in center hole) .
9. Insert tab in top of muffler cover into slot in top guard. Position cover over muffler and secure with three (3) screws.
10. Connect spark plug lead to spark plug.



## EXHAUST SYSTEM

### *Spark Arrestor Screen*

#### Level 2.

**Tools Required:** Cross Head Screwdriver, Soft metal brush, Wooden carbon scraper, 4 mm Hex Wrench

**Parts Required:** Screen P/N 14586240630  
Gasket P/N V104000003

1. Remove three (3) screws from muffler cover (A) and remove.
2. Remove screen holder (B), gasket (C) and screen (D) from muffler body.
3. Clean carbon deposits from muffler components.
4. Replace screen if it is cracked, plugged, or holes burned through.
5. Reassemble in reverse order of removal. Make sure screen is positioned properly before tightening screws.

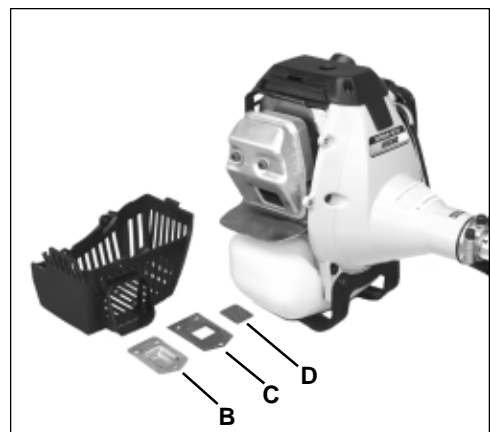
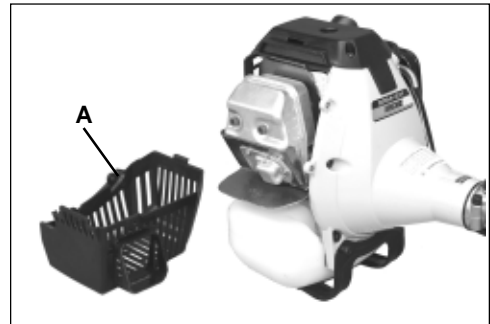
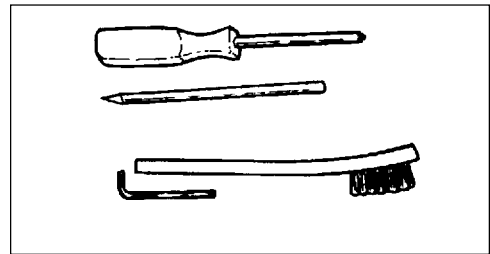

## CARBURETOR ADJUSTMENT

### *Engine Break-In*

New engines must be operated for a minimum of two tanks of fuel before carburetor adjustments can be made. During the break-in period, your engine performance will increase and exhaust emissions will stabilize. Idle speed can be adjusted as required.

### *High Altitude Adjustment*

High altitude adjustment is not required for proper operation of this engine.

### *Idle Speed Adjustment*

Idle speed adjustment may be required periodically to comply with specifications for this unit. See page 9, "Specifications," for correct idle speed.

#### **Level 2.**

*Tools required:* Screwdriver, Tachometer (ECHO P/N 99051130017).

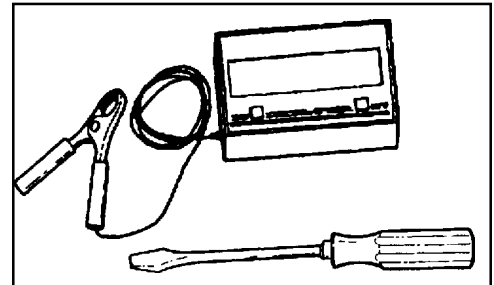

#### **NOTE**

Every unit is run at the factory and the carburetor is set in compliance with emission regulations. This carburetor does not have acceleration and high speed adjustment needles.

1. Check idle speed using a tachometer, and reset if necessary. Turn idle screw (A) clockwise to increase idle speed; counter clockwise to decrease idle speed.

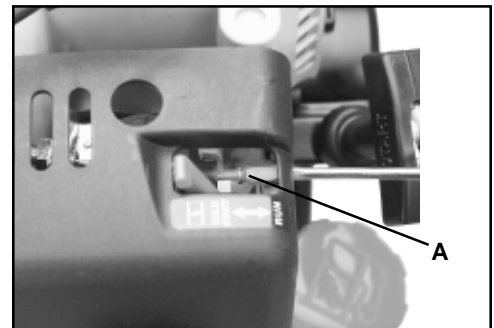

### **WARNING** **DANGER**

When carburetor adjustment is completed, the cutting attachment should not turn at idle, otherwise serious personal injury may result.

## LUBRICATION

#### **Level 1.**

*Tools Required:* Srench, Locking Tool, Screwdriver, 8 mm Open End Wrench

*Parts Required:* EchoLube™ 8 oz. (P/N91014) or Lithium Base Grease, Blade

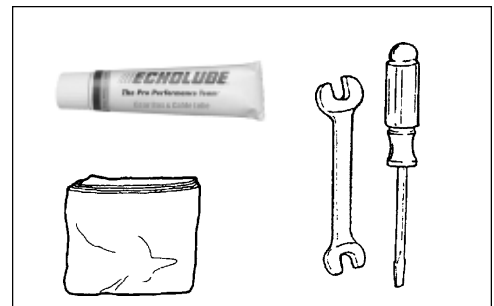

#### **NOTE**

Grease gear case every 50 hours of use. Replace blade when it is worn shorter than 6 inches. Remove blade and holders before greasing to prevent damage to gear and bearings.

1. Shut engine off.

- Remove cotter pin (A) and discard.
- Align hole in inner blade adapter (B) with notch in gear housing, and insert locking tool to prevent PTO shaft (C) from rotating.
- Remove L.H. blade nut (D) by turning in a clockwise direction. Remove outer blade adapter (E), blade (F), and inner blade adapter (B).
- Remove plug (G) and grease gear housing. Do not over-fill - grease will emerge between PTO shaft (C) and seal when overfull.
- Reassemble blade following steps 5 - 8 below.

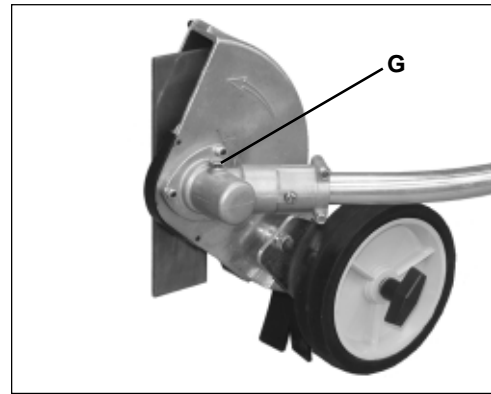

## BLADE REPLACEMENT

### Level 1

**Tools Required:** Locking Tool, 8 mm x 10 mm Open-End Wrench, Scrench

**Parts Required:** Blade, New Cotter Pin, Nut (Blade Kit)

- Shut engine off.
- Remove cotter pin (A).
- Align hole in inner blade adapter (B) with notch in gear housing, and insert locking tool to prevent PTO shaft (C) from rotating.

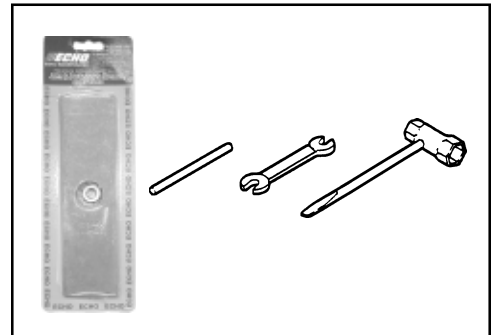

#### NOTE

Shield cover not shown for illustration clarity.

- Remove L.H. blade nut (D) by turning clockwise. Remove outer blade adapter (E), blade (F), and inner blade adapter (B).
- Install inner blade adapter (B) onto PTO shaft (C).
- Install and center blade (F) on inner adapter pilot (B).

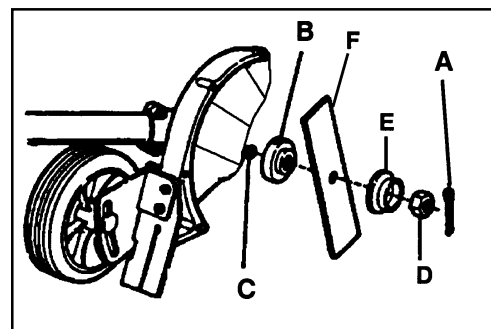

### WARNING DANGER

Use only ECHO-approved attachments. Serious injury may result from the use of a non-approved attachment combination. Read and comply with all safety instructions listed in this manual and safety manual. ECHO, INC. will not be responsible for the failure of cutting devices, attachments, or accessories which have not been tested and approved by ECHO.

- Install outer adapter (E) and nut (D). Tighten nut (D) firmly, turning counterclockwise (CCW).

#### IMPORTANT

Never reuse old cotter pin.

- Install new cotter pin (A) (#89850201130) to secure nut, and bend both legs of pin counterclockwise around PTO shaft.

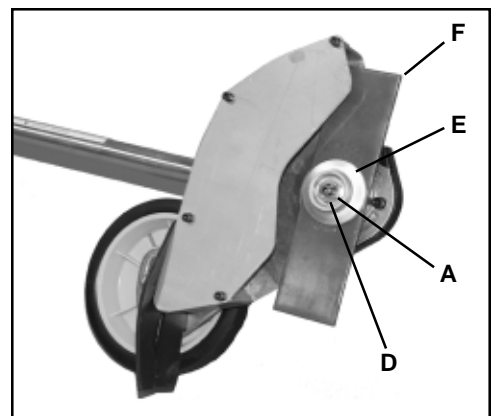

## TROUBLESHOOTING

**ENGINE PROBLEM TROUBLESHOOTING CHART**

Problem	Check	Status	Cause	Remedy
Engine cranks - starts hard/ doesn't start	Fuel at carburetor	No fuel at carburetor	Fuel strainer clogged Fuel line clogged Carburetor	Clean or replace Clean or replace See your Echo dealer
	Fuel at cylinder	No fuel at cylinder	Carburetor	See your Echo dealer
		Muffler wet with fuel	Fuel Mixture too rich	Open choke Clean/replace air filter Adjust carburetor See your Echo dealer
	Spark at end of plug wire	No spark	Stop switch off Electrical problem Interlock switch	Turn switch to ON See your Echo dealer See your Echo dealer
	Spark at plug	No spark	Spark gap incorrect Covered with carbon Fouled with fuel Plug defective	Adjust to .65mm (0.026 in.) Clean or replace Clean or replace Replace plug
Engine runs, but dies or does not accelerate properly	Air filter	Air filter dirty	Normal wear	Clean or replace
	Fuel filter	Fuel filter dirty	Contaminants/ residues in fuel	Replace
	Fuel vent	Fuel vent plugged	Contaminants/ residues in fuel	Clean or replace
	Spark Plug	Plug dirty/worn	Normal wear	Clean and adjust or replace
	Carburetor	Improper adjustment	Vibration	Adjust
	Cooling System	Cooling system dirty/plugged	Extended operation in dirty/dusty locations	Clean
	Spark Arrestor Screen	Spark arrestor screen plugged	Normal wear	Replace
Engine does not crank	N/A	N/A	Internal engine problem	See your Echo dealer

**WARNING  DANGER**

Fuel vapors are **extremely** flammable and may cause fire and/or explosion. **Never** test for ignition spark near an open spark plug opening, otherwise serious personal injury may result.

## STORAGE

### WARNING DANGER

During operation the muffler or catalytic muffler and surrounding cover become hot. Always keep exhaust area clear of flammable debris during transportation or when storing, otherwise serious property damage or personal injury may result.

### *Long Term Storage (over 30 days)*

Do not store your unit for a prolonged period of time (30 days or longer) without performing protective storage maintenance which includes the following:

1. Store unit in a dry, dust free place, out of the reach of children.

### WARNING DANGER

Do not store in enclosure where fuel fumes may accumulate or reach an open flame or spark.

2. Place the stop switch in the "STOP" position.
3. Remove accumulation of grease, oil, dirt and debris from exterior of unit.
4. Perform all periodic lubrication and services that are required.
5. Tighten all the screws and nuts.
6. **Drain** the fuel tank **completely** and pull the recoil starter handle several times to remove fuel from the carburetor.
7. Remove the spark plug and pour 7 cc (1/4 oz.) (1/2 tablespoon) of fresh, clean, two-stroke engine oil into the cylinder through the spark plug hole.
  - A. Place a clean cloth over the spark plug hole.
  - B. Pull the recoil starter handle 2-3 times to distribute the oil inside the engine.
  - C. Observe the piston location through the spark plug hole. Pull the recoil handle slowly until the piston reaches the top of its travel and leave it there.
8. Install the spark plug (do not connect ignition cable).

**NOTES**

## SERVICING INFORMATION

### PARTS

Genuine ECHO Parts and ECHO RE POWER® Parts and Assemblies for your ECHO products are available only from an Authorized ECHO Dealer. When you do need to buy parts **always** have the Model Number and Serial Number of the unit with you. You can find all three numbers on the engine housing. For future reference, write them in the space provided below.

Model No. \_\_\_\_\_ SN. \_\_\_\_\_

### SERVICE

Service of this product during the warranty period must be performed by an Authorized ECHO Service Dealer. For the name and address of the Authorized ECHO Service Dealer nearest you, ask your retailer or call: 1-800-432-ECHO (3246). Dealer information is also available on our Web Site. When presenting your unit for Warranty service/repairs, proof of purchase is required.

### ECHO CONSUMER PRODUCT SUPPORT

If you require assistance or have questions concerning the application, operation or maintenance of this product you may call the ECHO Consumer Product Support Department at 1-800-673-1558 from 8:30 am to 4:30 pm (Central Standard Time) Monday through Friday. Before calling, please know the model and serial number of your unit to help your Consumer Product Support Representative.

### WARRANTY REGISTRATION

You may register your Echo equipment using the warranty registration card or register on-line at [www.echo-usa.com](http://www.echo-usa.com). Registering provides a direct link between you and ECHO if we find it necessary to contact you.

### ADDITIONAL OR REPLACEMENT MANUALS

**Safety Manuals** in English/Spanish or English/French are available free of charge from your ECHO dealer, or at [www.echo-usa.com](http://www.echo-usa.com).

**Operator's and Parts Manuals** are available by:

- Downloading free from [www.echo-usa.com](http://www.echo-usa.com)
- Purchasing from your Echo Dealer.
- Sending a check or money order for \$2.00 per Parts Catalog or \$1.50 per Operator's Manual made payable to ECHO, INCORPORATED. State on a sheet of paper the model number and serial number of the ECHO unit you have, part number of the manual (if known), your name and address and mail to address above.

**Safety Videos** are available from your Echo dealer. A \$5.00 shipping charge will be required for each video.

#### Available Parts Catalog

PE-310

S/N 03001001 - 03999999

Part Number 99922203419



### DEALER?

Call

**1-800-432-ECHO**

or

**[www.echo-usa.com](http://www.echo-usa.com)**

### CONSUMER PRODUCT SUPPORT

**1-800-673-1558**

**8:30 - 4:30 Mon - Fri C.S.T.**

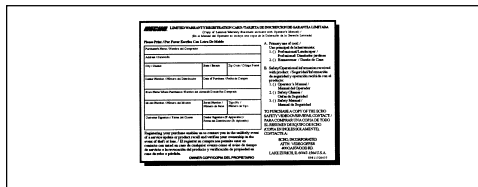

**ECHO**<sup>®</sup>  
ECHO, INCORPORATED

400 OAKWOOD ROAD  
LAKE ZURICH, IL 60047

[www.echo-usa.com](http://www.echo-usa.com)



*This Supplement contains important information. Please keep with your Operator's Manual.*

Your unit was manufactured using Echo's new open-face, all-metal blade guard and improved heavy-duty gear case.

**Specifications (Pg. 9)**

Gear Ratio ----- **2.07:1**  
Weight w/Blade ----- **7.1kg (15.7 lbs.)**

**Maintenance (Pg. 15)**

**Maintenance Intervals**

Drive Shaft                      Every **50** hours of use  
Gear Housing                    Every **15 - 25** hours of use

**Lubrication (Pg. 19)**

**Tools Required:** 13 mm wrench

**NOTE:** Grease gear case every **15-25** hours of use.

**SUPPLEMENT TO OPERATOR'S MANUAL  
PART NUMBER X7502126000 (X750003120)  
FOR MODEL: PE-310 POWER EDGER  
S/N 03002100 - 03999999  
SUPPLEMENT TO OPERATOR'S MANUAL  
PART NUMBER X7502125800 (X750002971)  
FOR MODEL: PE-311 POWER EDGER  
S/N 02001201 - 02999999**



*Este suplemento contiene la información importante. Guarde por favor con el manual de su operador.*  
Su unidad era manufacturada con el nuevo protector de Echo's de la lámina con la abrir-cara, y la caja mejorada del engranaje de calidad profesional.

**Especificación (Pagina 9)**

Relación de la caja de engranajes -- **2,07:1**  
Peso (seco) con cuchulla ----- **7.1 kg. (15.7 lb.)**

**Mantenimiento (Pagina 15)**

**Intervalos de mantenimiento**

Eje Motriz                              Cada **50** horas de operación  
Caja de engranajes                    Cada **15 - 25** horas de operación

**Lubricación (Pagina 19)**

*Herramientas requeridas:* llave de **13 mm**

**NOTA**  
Engrase la caja de engranajes cada **15-25** horas de uso.

**SUPLEMENTO DEL MANUAL DEL OPERADOR  
NUMERO DE PIEZA X7502126000 (X750003120)  
PARA LOS MODELO: PE-310 EL ORILLADOR  
N/S 03002100 - 03999999  
SUPLEMENTO DEL MANUAL DEL OPERADOR  
NUMERO DE PIEZA X7502125800 (X750002971)  
PARA LOS MODELO: PE-311 EL ORILLADOR  
N/S 02001201 - 02999999**





SUPPLEMENT TO OPERATOR'S MANUAL  
PART NUMBER X7502126000 (X750003120)

FOR MODEL: PE-310 POWER EDGER  
S/N 03002100 - 03999999

SUPPLEMENT TO OPERATOR'S MANUAL  
PART NUMBER X7502125801 (X750002971)

FOR MODEL: PE-311 POWER EDGER  
S/N 02001201 - 02999999

SUPLEMENTO DEL MANUAL DEL OPERADOR  
NUMERO DE PIEZA X7502126000 (X750003120)

PARA LOS MODELO: PE-310 EL ORILLADOR  
N/S 03002100 - 03999999

SUPLEMENTO DEL MANUAL DEL OPERADOR  
NUMERO DE PIEZA X7502125801 (X750002971)

PARA LOS MODELO: PE-311 EL ORILLADOR  
N/S 02001201 - 02999999

*This Supplement contains important information.  
Please keep with your Operator's Manual.*

*Este suplemento contiene la información  
importante.*

*Guarde por favor con el manual de su operador.*

### Description (Pg. 7 & 8)

19. **THROTTLE TRIGGER LOCKOUT** - This lever must be held during acceleration. Operation of the throttle trigger is prevented unless throttle trigger lockout lever is engaged.

### Descripcion (Pagina 7 y 8)

19. **SEGURO DEL GATILLO DEL ACELERADOR** - Esta palanca debe ser detenida durante el aceleración. La operación del acelerador del gatillo es prevenido a menos que la palanca de la seguridad del acelerador del gatillo haya endajado.

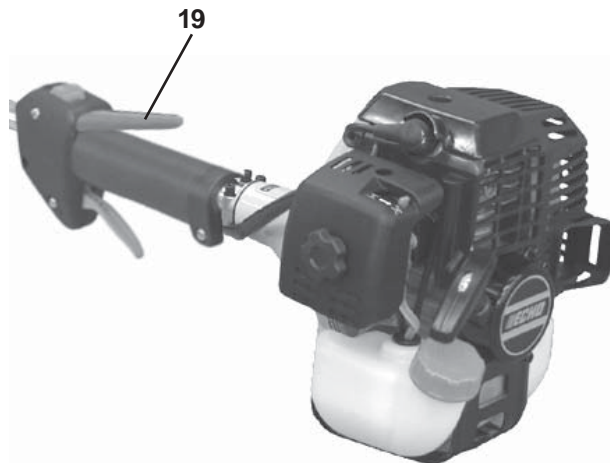

SUP22203678

99922203678  
05/03